

Digital Image Watermarking using Discrete Wavelet Transform

Hina Lala

School of System Science & Engineering, MDS University, Ajmer, India

Abstract - Nowadays internet has become a favorable medium for downloading multimedia content. Digital media can be copied very easily resulting in security issues. The digital content can be protected against counterfeiting, piracy and any unauthorized access by digital watermarking. Digital watermarking is an essential technique to add copyright notice, secret messages or verification messages to digital image signals, audio, video, or documents which is used for identifying the original creator and owner of digital content. In this paper discrete wavelet transform technique is used for embedding and extraction of watermark in original image by using alpha blending. The results show that the DWT technique is robust against various common image processing operations.

Key Words: Digital watermarking, Discrete Wavelet transform, Alpha Blending.

1. INTRODUCTION

Digital media can be stored efficiently and can be manipulated very easily using computers, resulting in various security issues. The problem of protecting the copyright of digital media can be solved by digital watermark. Digital watermarking is a concept of hiding ownership data into the multimedia data, which can be extracted later on to prove the authenticated owner of the media. Watermarking ensures authenticating ownership, protecting hidden information, prevents unauthorized copying and distribution of images over the internet and ensures that a digital picture has not been altered. There are basically two methods for watermarking: spatial domain and frequency domain. Spatial domain watermarking slightly modifies the pixels of randomly selected subsets of image pixels depending upon the image perceptual analysis. Frequency domain selects and modifies some frequencies from their original values according to particular rules. The frequency domain techniques are more popular than spatial domain techniques because it produces more robust and imperceptible watermarking. Based on the extraction technique watermarking algorithms are broadly categorized into two: Blind and Non-blind watermarking. The former does not require original image for extraction whereas the later requires original image for extraction process. In this paper non-blind watermarking is used which requires original image for extraction. The purpose of this paper is to study and implement Discrete Wavelet Transform (DWT) domain image watermarking system for real time image.

The paper is organized as follows. Section II contains general watermarking model. Section III contains DWT watermarking scheme, proposed techniques for watermark

embedding and extraction and section IV contains experimental results.

2. GENERAL MODEL OF DIGITAL WATERMARKING

A generalized watermarking model consists of two processes: watermark embedding and detection as shown in Fig. 1 and Fig. 2.

In the embedding process, the watermark may be encoded into the cover image using a specific key. This key is used to encrypt the watermark as an additional protection level. The output of the embedding process, the watermarked image, is then transmitted to the recipient.

In the detection process also called extraction process the watermark is extracted from the attacked signal. During the transmission if the signal is unmodified then the watermark is still present and can be extracted.

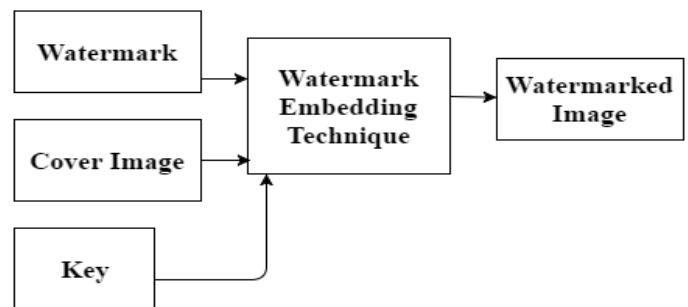

Fig -1: Watermark Embedding

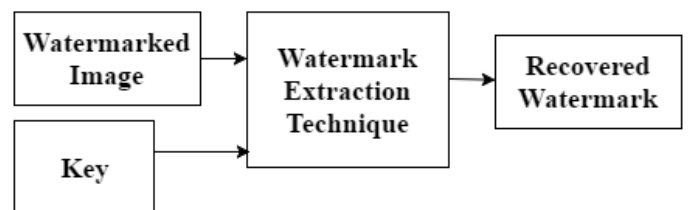

Fig -2: Watermark Detection

3. DISCRETE WAVELET TRANSFORM

Discrete Wavelet transform (DWT) is a mathematical tool for hierarchical decomposition of an image. The transformation is based on decomposing a signal into wavelets or small waves, having varying frequency and limited duration. The properties of wavelet decompose an original signal into wavelet transform coefficients which contains the position information. The original signal can be reconstructed completely by performing Inverse Wavelet Transformation on these coefficients.

DWT decomposes an image into sub images or sub bands, three details and one approximation. The bands are LL, LH, HL and HH. Fig. 3 shows the sub bands in DWT. LL contains low frequencies both in horizontal and vertical direction. HH contains high frequencies both in horizontal and vertical direction. HL contains high frequencies in horizontal direction and low frequencies in vertical direction. LH contains low frequencies in horizontal direction and high frequencies in vertical direction. The low frequency part comprises of the coarse information of the signal while high frequency part comprises of the information related to the edge components. The LL band is the most significant band as it contains most of the image energy and represents the approximations of the image. Watermarks can be embedded in the high frequency detail bands (LH, HL and HH) as these regions are less sensitive to human vision. Embedding into these bands increases the robustness of the watermark without having additional impact on the quality of the image. At each level of decomposition, first DWT is performed in the vertical direction, followed by the DWT in the horizontal direction. The first level of decomposition yields four sub-bands: LL1, LH1, HL1, and HH1. The LL sub band of the previous level is used as the input for every successive level of decomposition. This LL sub-band is further decomposed into four multi resolution sub-bands to acquire next coarser based wavelet coefficients. This process is repeated several times based on the application for which it is used.

DWT has excellent spatio-frequency localization property that has been extensively utilized to identify the image areas where a disturbance can be more easily hidden. Also this technique does not require the original image for watermark detection. Therefore it is used in various applications associated with signal processing like compression of audio and video, removal of noise. Digital image watermarking consists of two processes first embedding the watermark with the information and second extraction.

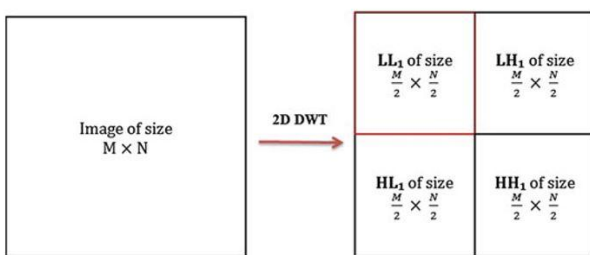

Fig -3: Sub-bands formed after 1-level DWT

3.1 Watermark Embedding

In this process 2D DWT is performed on the cover image that decomposes the image into four sub-bands: low frequency approximation, high frequency diagonal, low frequency horizontal and low frequency vertical sub-bands. Similarly 2D DWT is performed on the watermark image that has to be embedded into the cover image. Here we have used Haar wavelet. The technique used for inserting watermark is alpha blending. The decomposed components of cover image and watermark are further multiplied by a particular scaling

factor and are added. During the embedding process the size of the watermark should be smaller than the cover image but the frame size of both the images should be made equal. The watermark embedded in this paper is perceptible or visible in nature, so we embedded it in the low frequency approximation component of the cover image.

Alpha Blending Technique

According to the alpha blending technique the watermark image is obtained by:

$$WMI = k*(LL1) + q*(WM1)$$

Where WMI=Watermarked image, LL1=low frequency approximation of the original image, WM1=Watermark and k, q = Scaling factors for the original image and watermark respectively.

Finally inverse discrete wavelet transform is performed on the watermarked image coefficient to generate the final secure watermarked image.

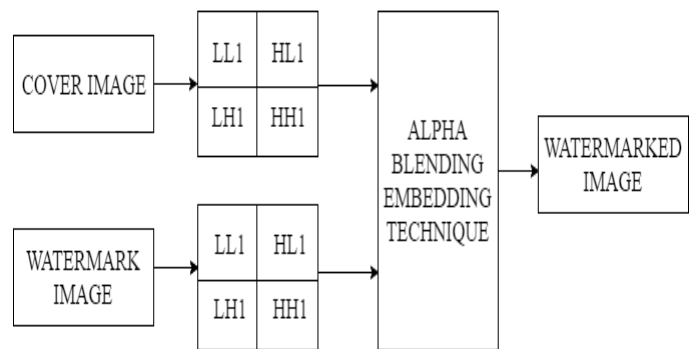

Fig -4: Watermark Embedding Process

3.2 Watermark Extraction

In this process the steps applied in the embedding process are applied in the reverse manner. First discrete wavelet transform is applied to both cover image and the watermarked image. After this the watermark is recovered from the watermarked image by using alpha blending technique.

Alpha Blending Technique

The alpha blending formula used for watermark extraction is given by:

$$RW = (WMI - k*LL1)$$

Where RW=Recovered watermark, LL1=Low frequency approximation of the original image, WMI=Watermarked image.

Finally inverse discrete wavelet transform is performed on the watermark image coefficient to generate the final watermark extracted image.

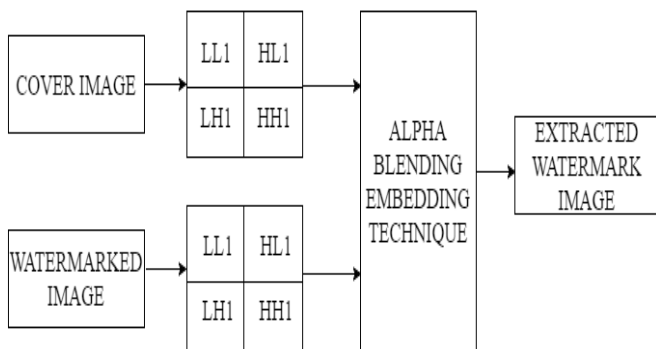

Fig -5: Watermark Extraction Process

4. EXPERIMENTAL RESULTS

In this paper we have used pepper image as the cover image and the fruits image as the watermark which are shown in Fig. 6 (a) and Fig. 6 (b) respectively. Both the images are of equal size of 512×512. The alpha blending technique used here adds the low frequency contents of the two images hence both images of equal size are taken.



Fig -6(a): Cover image



Fig -6(b): Watermark image to be embedded

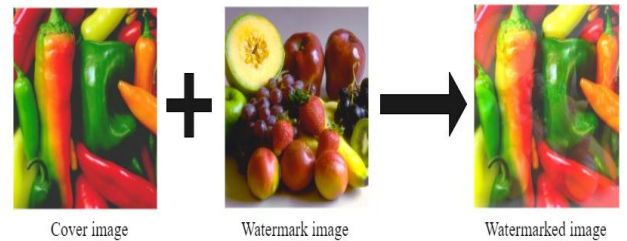

Fig -7: Watermark embedding process 1-level DWT

Fig. 7 shows watermark embedding process. Fig. 8 shows the watermarked image. Watermark embedding is done by varying the value of k from 0.1 to 0.9 keeping q constant at 0.1. Best results are obtained when k is 0.5. With the decreasing value of k below 0.4 watermark image gets brighter and completely destroys the cover image.



Fig -8: Watermarked image

Fig. 9 shows the watermark extraction process. Fig. 10 shows the extracted watermark image. Recovery of watermark image is done by varying value of k from 0.1 to 0.9. With the decreasing value of k below 0.2 recovered watermark becomes darker and completely invisible.

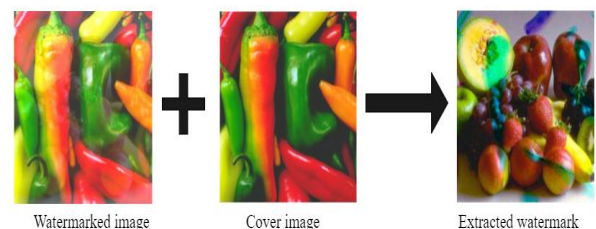

Fig -9: Watermark extraction process 1-level DWT



Fig -10: Extracted Watermarked image

5. CONCLUSIONS

In this paper a digital image watermarking technique based on discrete wavelet transform using alpha blending technique is implemented. This technique embeds visible watermark into the cover image. The cover image is required in the extraction process. The quality of recovered watermark image and watermarked image is depends on the scaling factors k and q .

Results obtained show that this technique is robust to various image processing operations

REFERENCES

- [1] Kaiser J. Giri, Mushtaq Ahmad Peer and P. Nagabhushan "A Robust Color Image Watermarking Scheme Using Discrete Wavelet Transformation", I.J. Image, Graphics and Signal Processing, 2015.
- [2] Nikita Kashyap, G. R. Sinha, "Image Watermarking Using 3-Level Discrete Wavelet Transform (DWT)", I.J.Modern Education and Computer Science, 2012, 3, 50-56.
- [3] Malika Narang, Sharda Vashisth, "Digital Watermarking using Discrete Wavelet Transform", International Journal of Computer Applications (0975 - 8887) Volume 74- No. 20, July 2013.
- [4] Pratibha Sharma , Shanti Swami, "Digital Image Watermarking Using 3 level Discrete Wavelet Transform", Conference on Advances in Communication and Control Systems 2013 (CAC2S 2013).
- [5] Akhil Pratap Singh, Agya Mishra, "Wavelet based watermarking on digital image", Indian Journal of Computer Science and Engineering Vol 1 No 2, 86-91.
- [6] Bushra Jamal , Athar Hussain, "Implementation and Comparison of Watermarking Algorithms using DWT", International Journal of Computer Applications (0975 - 8887) Volume 62- No.9, January 2013.
- [7] Nikita Kashyap and Sinha G.R., -Image watermarking using 2-level DWT||, Advances in Computational Research, Vol. 4, Issue 1, pp.42-45, 2012.
- [8] Arisudan Tiwari, Anooa Arya, Shubham Shukla, "Digital Watermarking Encryption and Decryption Using DWT", International Research Journal of Engineering and Technology (IRJET) May-2015 Volume 2 Issue 2.
- [9] Bhupendra Ram, "Digital Image Watermarking Technique Using Discrete Wavelet Transform And Discrete Cosine Transform", International Journal of Advancements in Research & Technology, Volume 2, Issue4, April-2013.
- [10] Heena Shaikh, Mohd.Imran Khan, Yashovardhan Kelkar, "A Robust DWT Digital Image Watermarking Technique Basis On Scaling Factor", International Journal of Computer Science, Engineering and Applications (IJCSEA) Vol.2, No.4, August 2012.
- [11] Shital Gupta, Dr Sanjeev Jain, "A Robust Algorithm of Digital Image Watermarking Based on Discrete Wavelet Transform" IJCCT Vol.1 Issue 2, 3, 4; 2010 for International Conference [ACCTA-2010], 3-5 August 2010.
- [12] Nilanjan Dey, Anamitra Bardhan Roy, Sayantan Dey, "A novel approach of color image hiding using RGB color planes and DWT", International Journal of Computer Applications, 2011.
- [13] Sweety JangraP, Pooja Ahlawat, "Performance of DWT based watermarking in presence of different attacks", International Journal of Scientific Engineering and Applied Science (IJSEAS) - Volume-1, Issue-4, July 2015.
- [14] Sanjay Rawat1, Balasubramanian Raman2. A New Robust Watermarking Scheme For Color Images, IEEE 2nd International Advance Computing Conference 2010
- [15] Jaya Jeswani, "1 Level DWT Image Watermarking Algorithm for RGB Cover Images and Watermarks", IOSR Journal of Computer Engineering (IOSR-JCE) e-ISSN: 2278-0661, p-ISSN: 2278-8727, Volume 17, Issue 5, Ver. II (Sep. - Oct. 2015), PP 48-54.