

## Study of Aerodynamics

Ms. Vidya Kumbhalkar<sup>1</sup>, Mr. Nilesh Khodke<sup>2</sup>, Prof. Aakansha Khaparkar<sup>3</sup>

<sup>1</sup>Final Year Student, Electrical Engineering, DES'sCOET Dhamangaon (Rly), Maharashtra, India

<sup>2</sup>Final Year Student, Electrical Engineering, DES'sCOET Dhamangaon (Rly), Maharashtra, India

<sup>3</sup>Assistant Professor, Electrical Engineering, DES'sCOET Dhamangaon (Rly), Maharashtra, India

\*\*\*

**Abstract** - This paper deals with the study of aerodynamics. Aerodynamics relates to the study of forces acting on a specific body. The study of aerodynamics of instability, which was responsible for the collapse of Tacoma narrow bridge, are significantly broadened by the use of aerodynamics system. The flutter is obtained to exhibit complex dynamics. Complex dynamics are influenced by the flow of induced motion of the body. Other objectives also included to obtaining aerodynamics force and moment data and determining the presence and magnitude of any dynamic aero-elastic behaviour in the fabric trailing edge. The aerodynamics law is used in any aero modelling. Aerodynamics also used in Aerospace, Aerodynamics of wind belt, wind tunnel, etc.

**Key Words:** Aero-dynamics, Aero-elastic, Aero-space, Aero- Modeling, Flutter, Wind Tunnel.

### 1. INTRODUCTION

#### 1.1 Definition

The 'ground effect' is the enhanced force performance of a lifting surface in a comparison to the free stream result, which is evident while operating in close proximity to the ground. The study of aerodynamics of an aircraft is mainly concerned with changes to the three-dimensional flow field introduced by the presence of the ground plane and their consequent impact upon overall performance. A prominent feature of the aerodynamics is a desirable increase in the lift-to-drag ratio.

#### 1.2 Historical Background

##### 1.2.1 Ground Effect Of Aircraft

Aircraft flying is close to the earth's surface over either ground or water the phenomenon becomes appreciable when operating within a distance of one wingspan from the boundary. The ground plane alters the flow field around the wing and resulting in a reduction in induced drag, an increase in lift. This phenomenon is known as the lift-to-drag ratio ( $CL / CD$ ) is generally around 3 for helicopters, 8 for hydro-airplanes, and around 12 for light aircraft. When this ratio contrast then, it can be as high as 20 or more for WIG flying vehicles if the ground clearance is less than or equal to one-fifth of the wing chord length. The so-called WIG craft exploits this behavior creating a unique class of high-speed and low-altitude transport vehicles. The ground effect was firstly investigated seriously around 1920. Wiesesberger

(1921) treated the problem with an extension of the Lanchester-Prandtl theory and utilized the basic concept of the induced drag of multi-planes. Tsiolkovsky(1927) described the ground effect and provided a theoretical solution for air cushion vehicles.

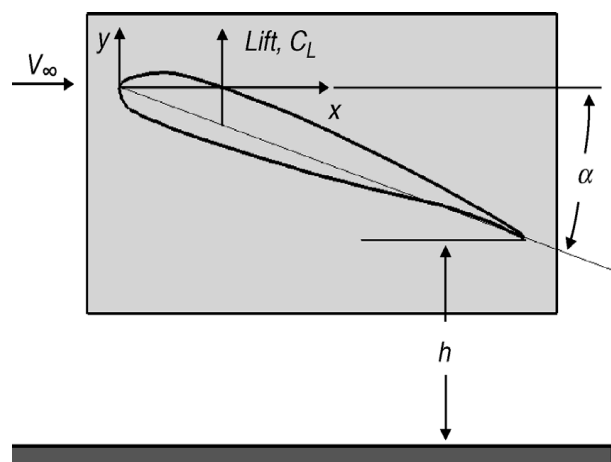

Fig -1(a): Wing of a WIG Aircraft

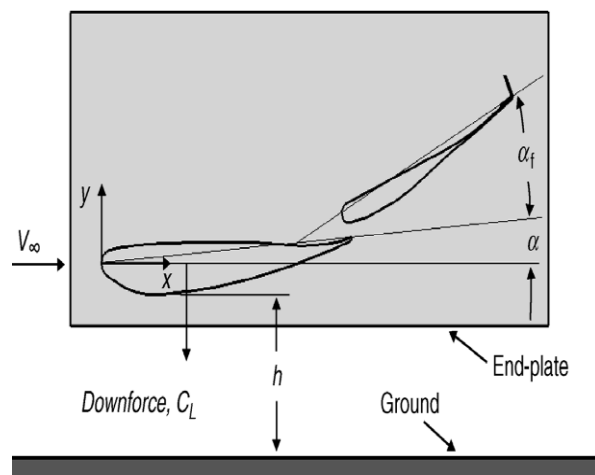

Fig -1(b): Front Wing of a Racing Car

'Air Resistance and the Express Train' since then, a large quantity of related research has been carried out and a better understanding of this phenomenon has been gradually achieved. Various types of ground effect aircraft

have been built around the world. Power Augmented Ram (PAR) is used and it is an important for the take-off of WIG vehicles. The jet engines exhaust gas the air displaced by propellers are directed or ducted. So that they pass underneath the wing to enhance the effect of the air cushion and to create additional lift. Following are the incorporation of the PAR principal by the American, Stewart Warner, in the design of his 1928 'compressor' airplane, many subsequent WIG vehicles adopted the concept. The economic benefits and practical applications of ground effect was observed in 1932 .

### 1.2.2 Ground Effect Of Race Car

The effect of an inverted wing placed in close proximity to a wall was first observed in the 1920s. The wind tunnel study, Zahm and Bear (1921) observed that complete set of readings also were taken with the ground plane above the aerofoil, that is, opposite to the cambered surface. The most striking features of these readings are the great increase of lift and the considerable increase of drag with proximity of the ground-plane. A WIG aircraft flying over water courtesy of WIG Vehicle Development Center of Chinese Academy of Science & Tech Following the Second World War the growth in popularity of open-wheeled racing on the newly abandoned military air fields saw the beginning of the modern closed-circuit motors racing culture. It became apparent that competitive advantage lies in the optimization of high-speed maneuver ability and control, enabling a greater capacity for lateral acceleration and consequent turning performance. Driving, braking, cornering and this forces are created at the contact patch between the tires and the road and magnitudes of these frictional forces are proportional to the vertical force applied through the tire itself. The Aerodynamic down force provided by an inverted wing can be used to supplement the low mechanical. Down force of a lightweight vehicle and increase the tire load without incurring any weight penalties that could adversely affect both lateral and longitudinal performance. The down force coefficient is clearly related to wing performance and can be enhanced through ground effect. Until 1966, aerodynamic considerations were limited to providing a streamlined design that sought to minimize drag but in this year. The following year and they made their first appearance on a Formula One vehicle. By 1970, the configuration had evolved to include a wing located at the back of the car, behind and above the rear wheels, together with a second lower wing ahead of the front wheels, which operated in ground effect. The vehicle possessed a sculpted underside with side-sealing skirts designed to create rapid

flow accelerations beneath the car, manipulating the Venturi effect to generate low pressure.



**Fig -2:** A WIG Aircraft Flying Over Water (Courtesy of WIG Vehicle Development Center of Chinese Academy of Science Technology Development).

## 2. THEORETICAL EXPLANATION

### 2.1 Ground effect aerodynamics of aircraft

In order to explain the ground effect, it is necessary to first define the aerodynamic forces on a wing. The aerodynamic force can be decomposed into two components i.e. lift normal to the free stream and drag parallel to the free stream. A wing generates lift due to the pressure differences between the pressure and suction surfaces. It moves through the air. At the wing tip the higher-pressure flow beneath the wing attempts to flow around the wing tip toward the low pressure area above the wing leading to the formation of trailing wing tip vortices. The primary effect of the vortices is to create a span wise distribution of downwash that acts to deflect the free stream flow around the wing in a downward direction leading to a reduction in local flow incidence. Consequently the overall lift generated by the wing reduces. Since the lift vector remains perpendicular to the local free stream and there is an increase in the drag equal to the product of the lift force and the angle through which it is deflected. Since the deflection itself is a function of the lift, the additional drag becomes proportional to the square of the lift. This additional drag contribution is known as induced drag or lift-dependent drag, since it is a consequence of lift generation. Fig. 3(a) & Fig. 3(b) shows a schematic of the wing tip vortices and the downwash which they induce. There are two aerodynamic changes associated with the ground effect: (i) a reduction of induced drag and (ii) the presence of an effective air cushion. When an aircraft is flying close to the ground surface within a distance of one wingspan the induced drag experienced by the aircraft is reduced because vertical component of the airflow around

the wing tip is limited and the trailing wing tip vortices are disrupted by the ground. The downwash intensity is therefore, reduced leading to a beneficial effect on lift and drag. If the aircraft is flying extremely close to the ground with in roughly 1/4 of the wing span. The air flow between the wing and the ground is compressed to form an air cushion. The pressure on the lower surface of the wing is increased creating additional lift and both of these effects lead to an increase in the lift-to-drag ratio. In the ground effect lift curve slope is seen to be enhanced. The reduced downwash generated by the wing tip vortices is shown to increase the effective angle attack.

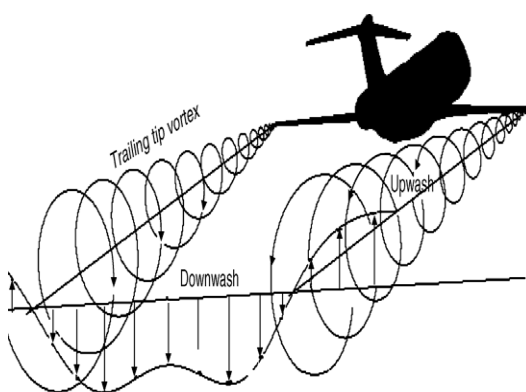

**Fig -3(a):** Illustration of the Wing Tip Vortices and Induced Downwash.

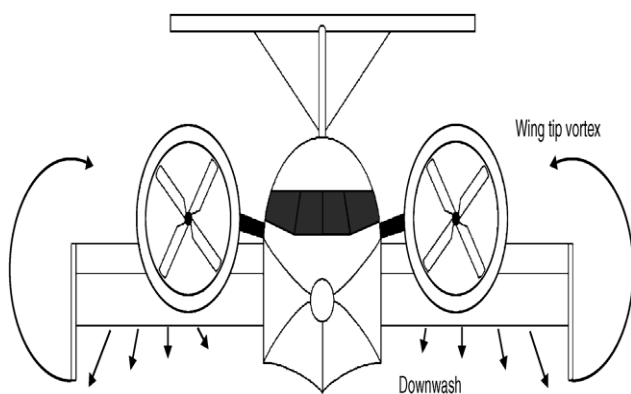

**Fig -3(b):** Reduction of Downwash in Ground Effect.

The two effects are classified to be span dominated and chord dominated. The ground effect becomes more pronounced the closer the wing is to the ground. The performance of a wing-in ground effect is dependent upon many factors (Fig. 3(a) & Fig. 3(b)). When the end plates are installed edge vortices are formed through separation

around the lower edge of the plate. The presence of these edge vortices is beneficial for force performance. In contrast to the wing tip vortices found on aircraft. The edge vortices lead to additional suction near the junctions between the wing and the end plates.

## 2.2 Ground effect aerodynamics of racecars

For a high-speed vehicle such as an open-wheeled race car. The flow around a number of components including the front wings, diffuser, and wheels is subject to the direct influence of ground effect. The enhanced aerodynamic response can have a significant effect on the overall force performance. A number of fluid flow phenomena are evident. These include:

1. Venturi-type down force enhancement mechanisms with reduction in ground height.
2. Down force-enhancing edge vortices attached to the endplates of wings and diffusers.
3. Separation as a normal fluid flow feature.
4. Suspension motion leading to unsteady flow.
5. Turbulent wake and ground boundary layer interaction.
6. Wall jet, shear layer instability, vortex meandering, and breakdown.
7. Compressibility effects.

A typical wing assembly generally consists of an inverted wing of multi-element configuration, end plates and often high-lift devices such as Gurney flaps. When the airfoil is set at a positive angle of attack, the gap between the suction surface and the ground forms a channel through which the flow initially accelerates. Negative pressure is produced rather similar to that in a Venturi type of pipe. The pressure then gradually recovers toward the trailing edge of the section as the channel passage expands begins with definitions, concepts then moves on to incompressible flow, low speed airfoil and wing theories, compressible flow, high speed wing theories, viscous flow, boundary layers, transition and turbulence, wing design and concludes with propellers and propulsion. The laws governing the behavior of the physical properties of air are applied to the transonic and supersonic flow speeds and the aerodynamics of the abrupt changes in the flow characteristics at these speeds, shock waves are explained. Then compressible flow theories are applied to explain the significant effects on wings in transonic and supersonic flight and to develop appropriate aerodynamic characteristics. Viscosity is a key physical quantity of air and its significance in aerodynamic situations is next considered in depth. The powerful concept of the boundary layer and the development of properties of various flows when adjacent to solid boundaries create a

body of reliable methods for estimating the fluid forces due to viscosity.

### 3. GROUND EFFECT OF AERODYNAMICS

#### 3.1: PERFORMANCE

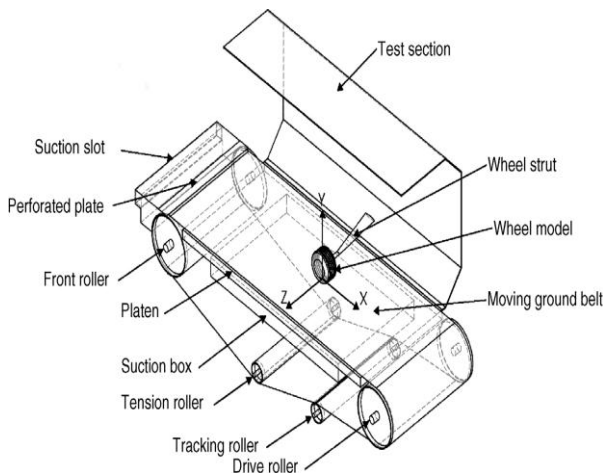

Fig -4: Schematic of a moving ground system

Ground effect aerodynamics has been widely used in the development of various vehicles. A thorough understanding and meticulous implementation of ground effect aerodynamics can maximize a vehicle's aerodynamic efficiency and improve the safety of the vehicles in operation.

#### 3.2: Aircraft in Take-Off and Landing

Ground effect aerodynamics has an important impact on the take-off and landing performance of an aircraft. For a constant pitch attitude, the lifting surfaces experience a larger angle of attack within ground effect conditions. For a heavily loaded aircraft required to operate on shortened airstrips, a large angle of attack has to be used. When it climbs out of the ground effect area, the loss in incidence may cause the aircraft to 'sink' and potentially stall if the flight speed is inadequate when the pilot corrects the aircraft pitch. This is thought to be the cause of many aircraft accidents. In contrast, when an aircraft descends toward the ground during the landing phase and below a distance of one wing chord, the reduced level of induced drag causes the aircraft to 'float' as the speed of the aircraft refuses to 'wash-off'. Any excess speed will make this float effect stronger leading to increased landing distances and potential pitch oscillations due to excessive control inputs. The rapid and continuous variation of speed and height with time, encountered during the take-off and landing phases of flight,

results in unsteady flow dynamics. As a consequence, the ground effect aerodynamic response must be carefully considered, and any sudden change in flight behavior must be recognized and predicted in order to prevent any risk of crash.

#### 3.3: Wing-In-Ground Effect Vehicle

In the middle of the twentieth century, many researchers realized that the ground effect phenomenon could be exploited to develop a new class of highly efficient craft known as WIG vehicles that would experience 30–50% less drag than a normal aircraft and could therefore travel further using the same amount of fuel. Since the 1960s, the former Soviet Union (now Russia) and many other countries have successfully built a number of WIG vehicles

### 4. CONCLUSION

The ground effect aerodynamics plays an important role in the take-off and landing phases of various aircraft and in the study of various plane. The plane is like the performance of hydroplanes flying close to the sea surface, high speed trains and high performance cars. It is the foundation for the research and the development of wing in ground (WIG) vehicles. This paper represents the study of ground effect of aerodynamics. The study of steady and unsteady aerodynamics behavior near solid ground and over water surfaces perturbed by wave motion. Also the study of vehicle flight dynamics, stability and control, aero-elastic phenomenon integrated configurations and vehicle optimization. The scope of ground effect study will be expanded and depend.

### REFERENCES

- [1] Baekho Heo, I.Y. Shen, And James J. Riley, "Reducing Disk Flutter By Improving Aerodynamic Design of Base Castings", *IEEE Sens. J.*, Sept2000. Vol 36, no. 5. pp. 2222-2224.
- [2] Ling Liu, XianwuLin, Shaoping Shen, "On The Aerodynamics Parameter Model Of The Stratospheric Airship". *Proceedings of The 33rd Chinese Control Conference* July 28-30,2014, Nanjng, China.
- [3] M. Li, H. Du, Q. Zhang, and J. Wang, "Improved Particle Image Velocimetry Through Cell Segmentation And Competitive Survival", *IEEE Trans Instrum. Meas.*, Jun 2008. Vol. 57, no. 6, pp. 1221–1229.

- [4] Zachary J. Taylor, Roi Gurka, Gregory A. Kopp And Alex Liberzon, "Long-Duration Time Resolved Piv To Study Unsteady Aerodynamics", *IEEE Sens. J.*, Dec.2010 Vol.59, no.12, pp. 3262-3269.
- [5] Yilei He, Qiulin Qu, and Ramesh K. Agarwal, "Shape Optimization of an Airfoil in Ground Effect for Application to WIG Craft", *Hindawi Publishing Corporation Journal of Aerodynamics Volume 2014, Article ID 931232, 11 pages.*

professor at Amravati university in Electrical Engg. And Specializes in Power System Engg and having one year teaching experience.

## BIOGRAPHIES



### Ms. Vidya Kumabhalkar

**Email:**

[vidyakumbhalkar555@gmail.com](mailto:vidyakumbhalkar555@gmail.com)

She was born in Gurukunj Mozari, Maharashtra, India in 1995. She completed her HSC Exam with First Class Division in 2012-2013 and pursuing B.E Degree in Electrical Engineering from Sant Gadge Baba Amravati University (SGBAU), Amravati, India, in 2014-2017.



### Mr. Nilesh Khodke

**Email:**

[nileshkhodke.2710@gmail.com](mailto:nileshkhodke.2710@gmail.com)

He was born in Arvi, Maharashtra, India in 1993. He completed his Diploma with First Class Division in Electrical Engineering in P. R. Patil polytechnic , Talegaon (sp) and pursuing B.E Degree in Electrical Engineering from Sant Gadge Baba Amravati University (SGBAU), Amravati, India, in 2014-2017.



### Prof. Aakansha Khaparkar<sup>3</sup>

**Email:**

[akanshakhaparkar@gmail.com](mailto:akanshakhaparkar@gmail.com)

Prof. Akansha Khaparkar was born in the Amravati, Maharashtra on 18 Aug. 1992. In 2014 she receive B,E. Degree in Electrical Engg. From SGBAU Amravati. From 2015 onwards she has been a