

STUDY ON MAXIMUM POWER EXTRACTION CONTROL FOR PMSG BASED WIND ENERGY CONVERSION SYSTEM

Ms. Dipali A. Umak¹, Ms. Trupti S. Thakare², Prof. R. K. Kirpane³

¹ Student (BE), Dept. of EE, DES's COET, Maharashtra, India

² Student (BE), Dept. of EE, DES's COET, Maharashtra, India

³ professor, dept. of DES's COET, Maharashtra, India

Abstract - A new and simple maximum power extraction control strategy proposed for the permanent magnet synchronous generator (PMSG) based variable speed wind energy conversion system (VSWECS). The PMSG is connected to the grid through a switch mode rectifier and a three phase voltage source (VSI) inverter. The generator side switch mode rectifier is controlled to accomplish maximum power from wind. Simple estimating of PMSG generator speed, using estimated generator speed to calculate mechanical power generated from wind, and optimum power coefficient can be accomplished from the relation governed the generator speed and mechanical power. The grid side voltage source inverter uses a hysteresis current controller to supply power at unity power factor into the grid. Wind energy is the fastest growing Non-Conventional energy source due to its free availability and environmental benefits. Maximum power extraction is a way to realize high power efficiency for Wind Energy Conversion System (WECS). In the mean time, the variable variable speed wind turbine are more popular compared to fixed speed wind turbine because of max. energy conversion and system frequency regulation.

Key Words: Hysteresis Current Controller, Maximum Power Extraction, Permanent Magnet Synchronous Generator, Switch Mode Rectifier, Variable Speed Wind Energy System.

1. INTRODUCTION

In recent years, wind energy has become the fastest growing power sector in the world and becomes more widely adopted in the future. Wind energy is the clean energy source and infinite natural resources, this is one of the available renewable energy source for the future. More than 35 GW of new wind power capacity was installed in 2013. The new global total at the end of 2013 was 318 GW, represented cumulative market growth of more than 12.3 %. By the year 2018, the global wind power capacity is expected to be 600 GW. In Egypt, 550 MW of wind power were installed. The total wind power installation is expecting to be 7200 MW by 2020. Variable speed wind energy systems have many advantages over constant speed generation such as operating at maximum

power point so energy captured can be increased, improved efficiency, and power quality.

Presence of power electronic devices with variable speed system is very important for this system, where AC-DC converter is used to convert variable voltage frequency from generator to DC voltage, the DC voltage is converted back to AC voltage with fixed amplitude and frequency at the grid for electrical utilization. Among the various grid connected types of wind turbines. It is directly driven permanent magnet synchronous generator has obtained rising attention due to several advantages such as it has simple structure, it can operate at low speed, self excitation capability, leading to high power factor and more efficiency operation. Extraction maximum power control is an active research area to get maximum possible power from the available wind power. There are two common types of interfaces between PMSG and the grid. The first is designed as back-to-back PWM converters, the second is a single switch mode rectifier and an inverter; the former one is commonly considering as the technical ultimate operation but may be more expensively and complex, it has a lot of switches which cause more losses and voltage stress in addition to the presence of Electromagnetic Interface (EMI).

1.1 Wind Energy Conversion System

Wind energy is the form of electricity that is created by wind turbine. Wind energy is used as a mechanical power that is transformed into electricity, with the use of a generator. Wind energy conversion system converts the kinetic energy of the wind into electricity or other forms of energy. A wind energy conversion system (WECS), or wind energy harvester is a machine that, powered by the energy of the wind, generate mechanical energy that can be used to directly power machinery (mill, pump ...) or to power an electrical generator for making electricity.

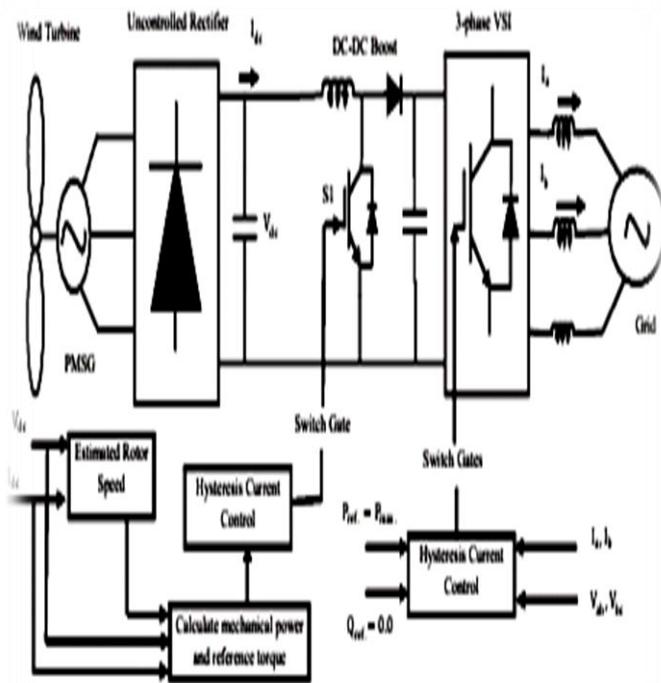

Fig. 1: Power control topology combined control structure

The system consists of wind turbine connected to a PMSG of 20 kW rated power which is directly driven without using gearbox in a single switch three phase mode rectifier, which consists of a three phase diode bridge rectifier and DC-DC boost converter, is used to capture maximum power extraction form wind. Additionally, a three phase VSI uses a hysteresis current controller to achieving unity power factor at the grid. Fig.1 shows that the power circuit topological structure and control of a variable speed wind turbine that proposed in this diagram.

1.2 Structure of Wind Energy Conversion System

The major components of a typical wind energy conversion system include a wind turbine, generator, interconnection apparatus and control systems, as shown in Fig. 2 Wind turbines can be divided into the vertical axis type and the horizontal axis type. Most modern wind turbines use a horizontal axis configuration with two or three blades, operating either down-wind or up-wind. A wind turbine can be designed for a constant speed or variable speed operation. Variable speed wind turbines can produce 8% to 15% more energy output as compared to their constant speed counter parts, however, they necessitating power electronic converters to provide a fixed frequency and fixed voltage power to their loads. Most turbine manufacturers have opted for reduction gears between the low speed turbine rotor and the high speed three-phase generators. Direct drive configuration,

where a generator is coupled to the rotor of a wind turbine directly, offers high reliability, low maintenance, and possibly low cost for certain turbines. Several manufacturers have opted for the direct drive configuration in the current turbine designs.

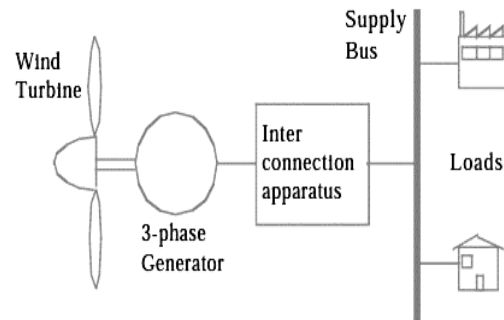

Fig. 2 structure of wind energy conversion system

At the present time and in the near future, generators for wind turbines will be synchronous generators, permanent magnet synchronous generators, and induction generators, including the squirrel cage type and wound rotor type. For small to medium power wind turbines, permanent magnet generators and squirrel cage induction generators are often used because of their reliability and cost advantages. Induction generators, permanent magnet synchronous generators and wound field synchronous generators are recently used in various high power wind turbines. Interconnection apparatuses are devices to achieve power control, soft start and interconnection functions. Very often, power electronic converters are used as such devices. Most modern turbine inverters are forced commutated PWM inverters to provide a fixed voltage and fixed frequency output with a high power quality. Both voltage source voltage controlled inverters and voltage source current controlled inverters has been applied in wind turbines. For certain high power wind turbines, effective power control can be achieved with double PWM (pulse width modulation) converters which provide a bi-directional power flow between the turbine generator and the utility grid.

1.3 Permanent Magnet Synchronous Generator

A permanent magnet synchronous generator is a generator where the excitation field is provided by a permanent magnet instead of a coil. Permanent Magnet Synchronous Motors (PMSGs) has been widely used in many industrial applications. The permanent magnet rotor was constructed based on the stator frame of a three-phase induction motor. This design is performed in order to achieve a sinusoidal back EMF with changing the stator geometry and winding. Each pole of the rotor is fixed with

several magnet blocks. Permanent magnet synchronous generator (PMSGs) has been widely used in many industrial applications due to their compactness and high torque density shown in fig. 2 PMSGs are mostly used in high-performance drive systems. The permanent magnet synchronous generator eliminates the use of slip rings for field excitation, resulting in low maintenance and low losses in the rotor. The PMSGs have the high efficiency and are appropriate for high performance drive systems such as CNC machines, robotic and automatic production systems in the industry. The permanent magnet synchronous generator is an AC electric machine like that an induction generator but with some changes in design features like in an induction generator the rotor has to be supplied with DC current to produce a field that produces three phase AC power from the stator of the induction generator, whereas in PMSGs as the name suggests the rotor is a permanent magnet so there is no need for the DC excitation so no need of commutator and brushes hence reducing the commutation losses and also the constructional costs.

1.4: Maximum Wind Power Extraction

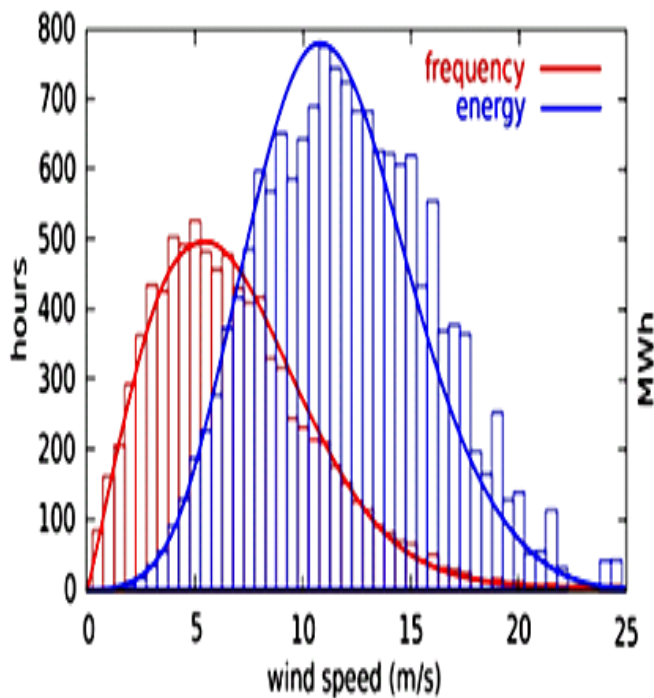

Fig. 3: Distribution of Wind Speed (red) and Energy (blue)

Wind turbines work under variable wind speed conditions. Wind is stochastic and is changing all the time. Wind characteristics affect the output power of WECS. Fig. 3 below shows a probability distribution function which fits to the observed data. Different locations may have

diverse wind speed distribution. WECS should be able to make adjustment to the variation of wind so that it can generate maximum power with high efficiency at any time. In Fig.3, if the wind turbine speed can keep track of the wind speed changes, maximum power could be extracted. For example, when the wind speed is 12m/s, maximum power is obtained when the turbine speed is at 1 per unit. Maximum Wind Power Extraction algorithms implemented in the control mechanism of WECS can guarantee wind turbines working under safe condition along with high efficiency.

1.5 Simulink result

To check the proposed algorithm of extraction maximum power control technique from wind turbine and achieved by unity power factor at the grid, the whole systems has been simulated using MATLAB / SIMULINK software program. The wind speed steps up at time 1.5 second from 8.5 m/sec. to 12 m/sec. during 0.5 second time span and at time 3.25 second it steps down from 12 m/sec. to 10 m/sec. also during 0.5 second time span as shown in Fig.(a). Fig.(b) shows that the estimating and calculating generator speed where it changes with changing the wind speed to obtain optimum power coefficient C_p and consequently extract maximum power from wind turbine. The percentage error between the calculating and estimating generator speed is found less than 2% as shown in Fig.(c). Fig.(d) shows that the value of power coefficient C_p , it is cleared that the simple control technique work well where the value of power coefficient kept its optimum value which equal 0.48 with varies the wind speed to obtain maximum power. Fig.(e), (f), and (g) indicated the instantaneous output phase voltage and phase current (phase current multiplied by 3 to indicated the phase relation between it and voltage) of a phase (phase A) from output three phase when the wind speed transfer from 8.5 m/sec. to 12 m/sec., 12 m/sec., and 10 m/sec., respectively. Which cleared the unity power factor at the grid is achieving with different wind speed. The average output power according to the wind speed is shown in Fig. 4. 2. (h), whereas this value of the power is the maximum extracted power from available wind power because the value of power coefficient C_p is at optimum value.

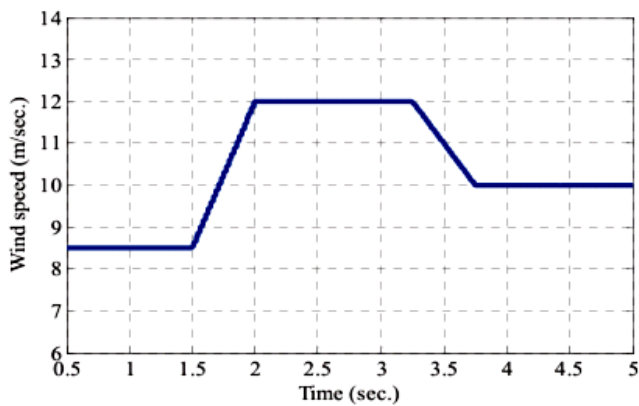

(a) Changing in wind speed (m/sec)

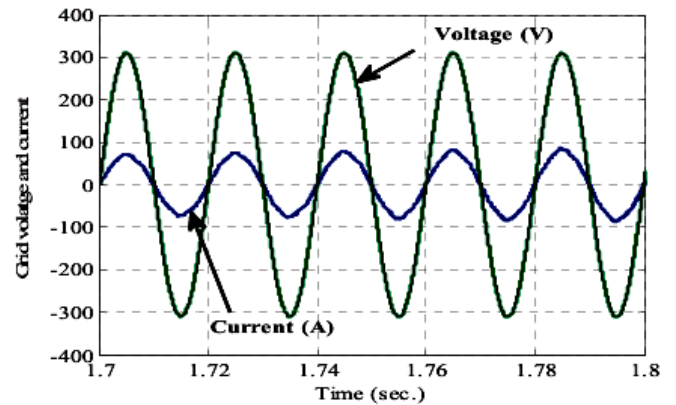

(e) Grid voltage and current with increasing wind speed from 8.5 m/sec to 12 m/sec

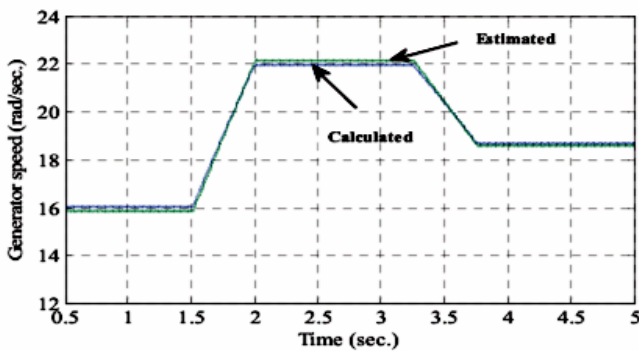

(b) Estimated and calculated generator speed (rad/sec.)

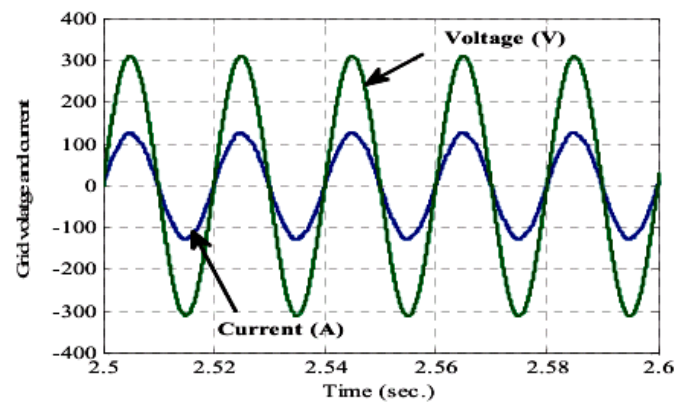

(f) Grid voltage and current when wind speed is 12m/sec

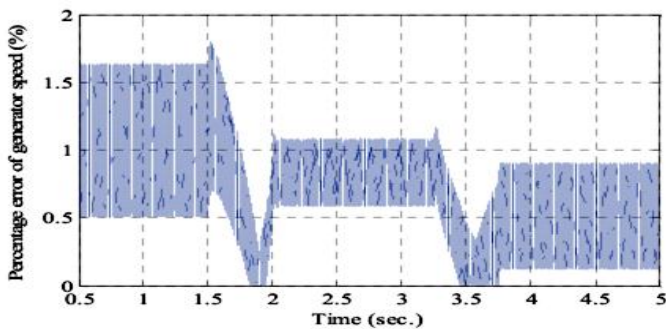

(c) Percentage error of generator speed (%)

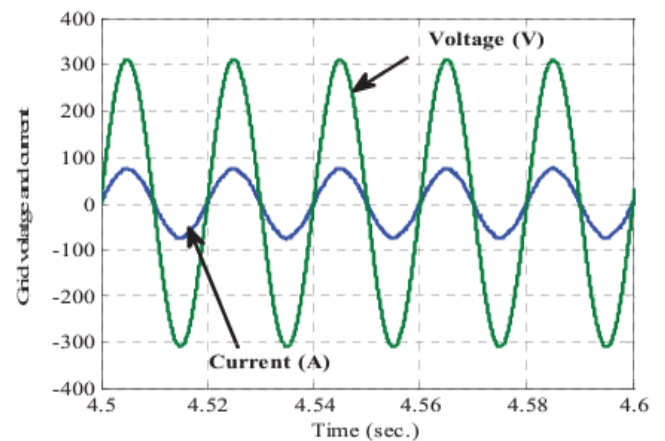

(g) Grid voltage and current when wind speed is 10 m/sec

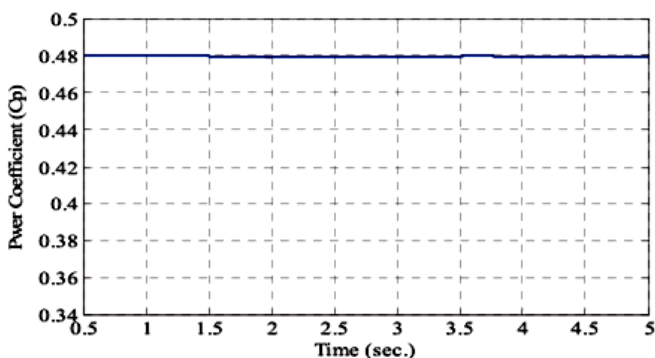

(d) Power coefficient (Cp)

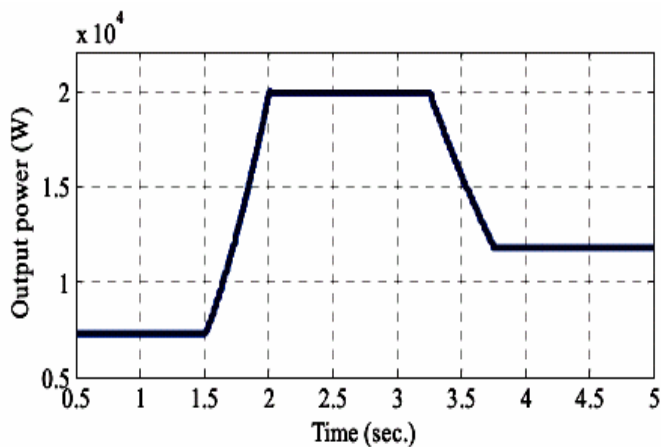

(h) Maximum output power from wind

Electronics Specialists, PESC, *IEEE Conference*, pp. 4003 – 4007, June 2008.

- [4] M. E. Haque, M. Negnevitsky and K. M. Muttaqui, "A Novel Control Strategy for a Variable-Speed Wind Turbine with a Permanent-Magnet Synchronous Generator," *IEEE Transactions on Industry Applications*, vol.46, no. 1, pp. 331-339, Jan./Feb. 2010
- [5] S. Muller, M. Deicke and R. W. De Doncker, "Doubly fed induction generator system for wind turbines," *IEEE Industry Applications Magazine*, vol. 8, no. 3, pp. 26-33, May 2002.

Conclusion

Control strategy for a variable speed wind energy conversion system with a PMSG is presented along with a comprehensive analysis and simulation using MATLAB / SIMULINK. Maximum power extraction control algorithm is employed based on estimating generator speed, using the relation curve between generator speed, mechanical power and making the generator speed operated at optimum value through a hysteresis current controller harvest the maximum power from the obtainable wind power. The controller is capable to maximize output of the variable speed wind turbine under fluctuating wind. A simple hysteresis current controller is employed on the grid side to connect the system with the grid at unity power factor. Simulation results prove that the proposed control scheme has a great capability to obtain unity power factor at the grid side while deriving maximum power extraction from available wind power.

REFERENCES

- [1] [1] A. J. G. Westlake, J. R. Bumby and E. Spooner, "Damping the power angle oscillations of a permanent magnet synchronous generator with particular reference to wind turbine applications," *IEE Proceedings, Elec. Power Appl.*, Vol 143, No 3, pp. 269 – 280, May 1996.
- [2] H. Polinder, F. F. A. Van der Pijl, G. J. de Vilder and P. J. Tavner, "Comparison of direct-drive and geared generator concepts for wind turbine," *IEEE Transaction Energy Conversion*, vol. 3, no. 21, pp. 725- 733, Sep. 2006.
- [3] J. Hui and A. Bakhshai, "A new adaptive control algorithm for maximum power point tracking for wind energy conversion systems," *Power*