

Implementation of Customised SCADA for Cartoner Packaging machine for Cost Effective Solution

Prof. V.B. Kumbhar¹, Prof. S.D. Gokhale²

Prof. V.S. Kumbhar³, Prof. M. K Patil⁴

^{1,2,3,4} DKTES's Textile & Engineering Institute, Electronics Dept,
Ichalkaranji, India.

Abstract – In Factory Automation engineers are looking for the use of Visual Basic for the implementation of SCADA applications for several reasons. Most of the SCADA applications require a very less number of user input parameters and data logging, monitoring and trending functionalities to be visualised by the user. In Industrial environment, there are times when traditional SCADA based solutions provide most of the functionality but at a much higher cost than budgets allow for small OEM customers. By utilizing Visual Basic's integrated event based user interface design and database connectivity functionality like SQL and adding off-the-shelf plug-in's like ActiveX controls or DLL or MSCOMM components to produce frontend graphics, trending, communication, and alarming. Developers, OEMs, integrators, and users can create industrial HMI or SCADA applications. The designed VB based SCADA is commensurate with: A real-time view of the industrial process; reduction in the downtime and troubleshooting time for faults; safety of operating personals. OEM industries can easily adapt to the implementation of customized SCADA as part of their industrial machine automation to make process visualization of the plant easier, locate faults rapidly and to help replace humans in tasks done in dangerous environments. This paper is an effort to show that VB can be successfully implemented for Packaging machine as a SCADA alternative.

Keywords— Delta PLC, Visual Basic, Modbus.dll, Packaging Machine

1. INTRODUCTION

The usage of PLC in automation industry has been wider nowadays. With PLC as the machine controller in the production assembly lines, it has increased the production and quality of the product. However, even within latest advanced technology there will be a time that something unpredictable occurred. Where, machine breakdown is the most unwanted things. The longer the breakdown is, the longer it will affect the production. A way to reduce the downtime period is to show the machine process or PLC process where we can easily see the breakdown situations or parts. PLC ladder diagram display often use as the display of PLC process. However the display of ladder program is complex and not systematic. The purpose of this paper is to

design a GUI that is suitable to replace the ladder diagram display. It also can facilitate the process of reconfiguring and troubleshooting. Within this condition the breakdown duration will be decreased and production will improved [2].

Industrial application engineers have two main approaches for interacting with Industrial processes via a solid state device universally known as programmable logic controllers (PLCs).

- Firstly they can utilise a pre-programmed human machine interface (HMI), which are complete hardware package and ready to use.
- Secondly they can customize their own solution.

HMI software packages are appealing to developers because many complex tasks are not visible to user. Purchasing the licences for development and runtime software from an authorized local distributor, installing it into development PC and then configure, debug is just an easy task [10]. Afterwards deploy the necessary runtime applications, exe and configuration files on to users PC or PCs.

Because the changing development environment and behavior of each HMI vendor's software varies, user needs to cope up with specialized skills to accomplish similar tasks. Programming softwares, proprietary communication protocols, material costs also vary by HMI vendors and are solely delivered only through exclusive distributor network channels [10].

Cost of SCADA implementation for multiple deployments is an even big issue. Before user can actually deploy solution to PCs, portable devices, or Web servers, user must typically have to pay for additional runtime software licenses. If user have more than a couple of customers, this cost is a considerable expense, often making this approach cost-prohibitive, especially if user is paying for more functionality than you actually never used[1].

The main aim of any SCADA system is to assist the user in running, maintaining a machine and managing a industrial process. A good SCADA system will increase the productivity of the machine, reduces downtime, and assist in providing consistent good product with good quality. The required functionality of SCADA will change based upon the complexity and type of product produced the type of

machinery used, the skills of the operator [3]. The major functionality typically included are:

- 1) Communication Link between PLC and PC.
- 2) Visual HMI Trending Real Time and Archived Data [3].

Some advantages of Using Visual Basic as HMI/SCADA for industrial applications:

- 1) Visual Basic Provides optimal solution for developing HMI/SCADA applications.
- 2) No runtime Fees and royalties.
- 3) Visual Basic with industrial connections is solution to costly proprietary automation Software's.
- 4) Visual Basic is widely used development environment in the world and the industrial automation community is walking up to the appeal of the cheap, well supported, large developer base that Visual basic provides.

2. METHOD OF INTERFACING

In this research work we propose the general block diagram of the system architecture, where there are a controller PLC and a server computer [9]. The PLC is connected to the server through the RS-232C serial Modbus communication Link. The Industrial logic functions are implemented by a Ladder logic realized by the PLC while the user interface is done by means of software designed and loaded in the server computer [13].

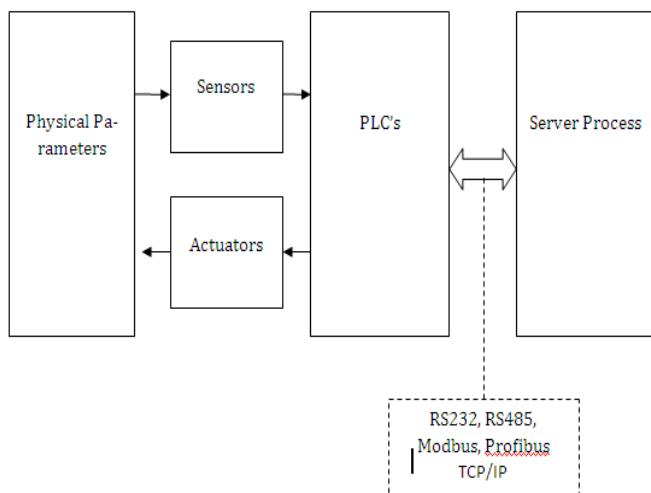

Fig.1: Block diagram

The software is implemented using Visual Basic and based on utilizing the especially created ActiveX control tool which enables communication between the PC and the Delta PLC in a very user friendly manner. Connecting the server to a network enables monitoring and administrating the PLC using remote clients.

3. DESIGNING OF PLC PROCESS

Fully automatic or semi-automatic cartoning machines uses optics, mechanisms, electricity and gas are controlled by a PLC. They are used for automatic cartoning of plate-like or bottle-like objects such as medicine, food and health products, and can automatically complete delivery of items, fold and deliver instructions, form and deliver carton, load items and instructions into cartons, seal the two ends of the carton, and remove unqualified products automatically.

They can be linked with blister packaging machines, forming a packaging line. Cartoning machines can be roughly classified into plate-type automatic cartoning machines (cartoning objects are mostly medicine strips packed by blister packaging machines) and bottle-type automatic cartoning machines (cartoning objects are mostly medicine bottles); the process of the two types of machines is roughly the same, mainly for the Pharma industry. Now a days the speed of cartoning machines is typically 80 and 100 bottles/min.

Following figure shows operational working of Horizontal cartoning machine

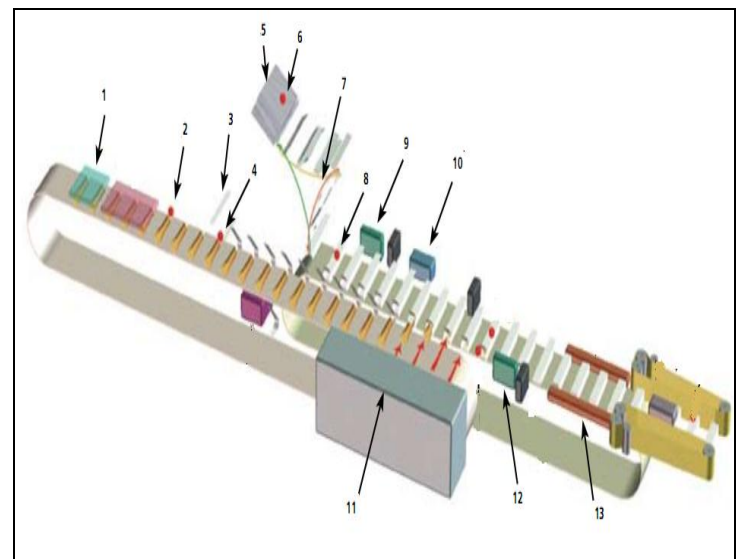

Fig 2: Operation Cycle of Horizontal Cartoner Machine

Operation Cycle of Horizontal Cartoner Machine

1. Product infeed.
2. Product detection.
3. Leaflet infeed.
4. Detection of leaflet in leaflet pocket.
5. Carton magazine.

6. Level control.
7. Rotary carton erection/oscillating arm
8. Detection of carton in carton chain.
9. Closing of side flaps.
10. Carton transfer system.
11. Product pushers including product infeed switch.
12. Closing of side flaps.
13. Closing system.

Product Infeeding :

The machine is equipped with a Product bottles where the bottles is placed up on conveyor with the help of Star wheel. The star wheel conveyor is equipped with bottle sensor which stores presence or absence of bottle. This event is synchronized with the help of Cam. Product Infeed ensures that the bottles are placed on the bottle conveyor correctly.



Fig 3: Product Infeeding

Leaflet Infeed

The machine is equipped with leaflet magazine where the leaflet is picked up on conveyor. The leaflet magazine can be bypassed from its operation as some products does not contains leaflet.



Fig.4 :Leaflet Infeed

Leaflet is moved by conveyor to the line parallel to pocket conveyor allied Bottled line. While being moved by carton chain rack carton is formed & prepared to receive the product. Other photocells are fixed in the magazine they check for proper carton pick up.

Carton Feeding

The machine is equipped with carton magazine where the carton is picked up on conveyor. The carton magazine is equipped with a carton minimum load photocell called as Minimum carton load sensor' Carton is moved by conveyor to the line parallel to pocket conveyor allied carton line. While being moved by carton chain rack carton is formed & prepared to receive the product. Other photocells are fixed in the magazine they check for proper carton pick up.



Fig.5: Carton Feeding

Carton Forming

Carton is formed while being moved along the line parallel to pocket chain. Carton forming process is pneumatically operated. Two suction paths pick up & set the

two carton sides part further mechanical components fold the side flaps.



Fig6: Carton Forming

The chain transport & forming conveyor are equipped with two photocells 'Upper forming check' & 'Lower forming check' Carton above the conveyor is guided at the top by mobile guide here an inductive sensor called as 'Carton guide up sensor' is attached for this.

Product Insertion

Products are inserted into the carton by pusher. Pusher is equipped with safety device which move back the pushers guide in case the product is harmed to be inserted. Safety system is controlled by the sensor 'Pusher Safety Sensor' that avoid further damages to the machine.

If blisters are not placed properly or they are not present inside pocket or bucket pusher comes in contact Leaflet is also inserted along with blisters inside the carton by the pusher. Mobile plate plays important role in this process. Mobile plate catches the leaflet meanwhile pusher pushes the fixed number of blisters inside mobile plate in such away that leaflet holding all blisters moves inside carton.



Fig7: Product Insertion

Side Flap Closing & Numbering

Ensuring for proper side flap closing of each carton (whether properly formed or not) are palced on carton carrying conveyor guide before that every carton has to through central numbering device. Side Flaps are closed using simultaneous movement of central comb which is located in between two side comb.

While carton moved along conveyor carton code is read by carton code reader then with the help of flap closure flap A , A' & B,B' are closed further lower flap numbering & upper flap numbering is performed. Knives placed alongside of central gripper comb folds the flap C, C' & tuck in closer perform final closing. At the end rejected cartons are diverted to different direction & properly formed cartons are come out through outlet.



Fig8: Side Flap Closing & Numbering

4. RESULTS

Although its main purpose is simple to understand, a cartoner is the summation of a number of individual processes that all must be coordinated in order to successfully insert a product into its packaging container. Used largely in food and beverage industries, the cartoner is applicable to a variety of products ranging from inserting pouches of food product into a box, to inserting pharmaceutical bottles into their shipping container. While the cartoner was mainly a mechanical contraption in yesteryear, today's cartoner is an automated, synchronized machine capable of high-speed and integrated operation.

Using VB and DMT.dll customised SCADA is developed for application for continuous horizontal cartonning Machine.

Application overall Results:

1. Reduced Mechanical Components - eliminate mechanical components to achieve fall-through design and eliminate mechanical slippage and stretch
2. Synchronized Motion for all Axes - coordinate all motion of the feed belts, flap tuckers, carton feeder, and loaders for high speed throughput
3. Quick Product Changeover - flexible motion controller to store and create variable product sizing selectable through HMI interface
4. Increased Throughput - coordinate axes for faster continuous motion
5. Reduced Downtime - offer greater uptime by streamlining the application process, eliminating mechanical breakage, and reducing product changeover time

In this GUI continuous horizontal cartonning Machine can be operated in both auto & manual mode. Production Counter and Machine Speed are displayed on the GUI. In DMT Modbus.dll user read four Modbus data registers simultaneously. GUI also shows the status of all Inputs like bottle Sensor, Leaflet sensor, Low carton level. GUI also shows the status of all output like cylinder 1, cylinder 2, and cylinder 3, VFD. Following figures shows the GUI Screens in sequence.



Fig9: Splash Screen

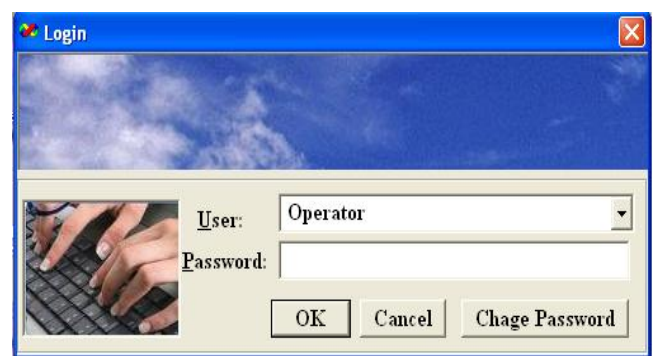

Fig10: User Login Screen

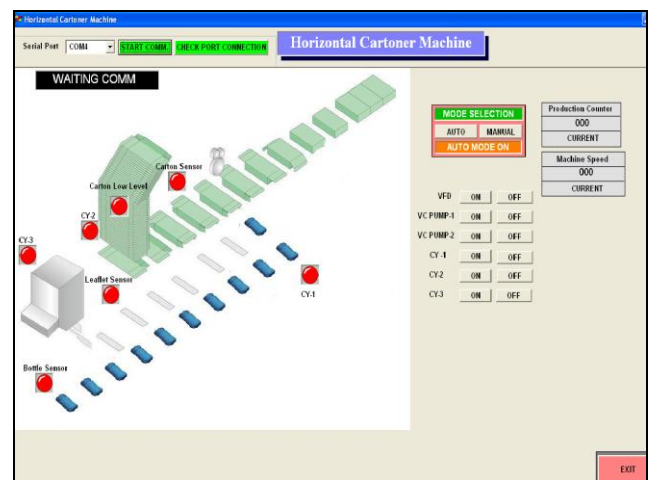

Fig11: Complete GUI for Cartoner Machine

5. CONCLUSIONS

The designed SCADA is commensurate with: A real-time view of the industrial plant; reduction in the troubleshooting time for faults; and safety of operating personnel. Manufacturing industries can easily adapt to the implementation of SCADA as part of their industrial automation systems to make process visualization of the plant easier, locate faults rapidly and to help replace humans in tasks done in dangerous environments.

REFERENCES

- [1] Tahir Nizamuddin, Bilal Iqbal. "Design and Implementation of Locally Developed SCADA A Cost Effective Solution". PCSIR, Institute of Industrial Electronics Engineering, (IIEE) Karachi 16(2010)
- [2] http://www.edata.omron.com.au/eData/Servo_Controllers/U04P-E-01.pdf
- [3] Tieyi Zhang, Yun Zhang, Xiaorong Zhou. "Development on Serial Communication between Panasonic Electrical PLC and Computer based on VB". Guangxi University, Nanning, China. Applied Mechanics and Materials Vols, 170-173(2012)
- [4] S.S.Bidwai, V.B.Kumbhar. "Real Time Automated Control using PLC-VB Communication" International Journal of Engineering Research and Applications (IJERA) Vol. 3, Issue 3, pp.658-661 (Jun 2013),
- [5] Naregalkar Akshay. "Real Time Automated Control of Industrial Processes with PLC –LABVIEW Communication", .Ibrahimpnam, Hyderabad, India, Issue-1, Vol-1, 035-038(2008)
- [6] "Modbus communication Manual" MTL 8000 process control for process I/O ,The MTL Instruments Group PLC, England
- [7] "DVP PLC communication Protocol," Delta Electronics Inc,www.delta.com.tw/industrialautomation (1998).
- [8] "Using MODBUS for Process Control and Automation". The Interface Solution Experts, www.miinet.com
- [9] SavasŞahin, "Modbus-Based SCADA/HMI Applications", Journal of Information Technology and Application in Education Vol. 2 Issue. 2, (2013)
- [10] White paper on "Unlocking the power of .NET for industrial automation" International www.ingeardrivers.com. (2009)
- [11] T.Kalaiselvi, R.Praveena ,Aakanksha.R,, Dhanya.S, "PLC Based Automatic Bottle Filling and Capping System With User Defined Volume Selection," IJETAE., Volume 2, Issue 8, (August 2012).
- [12] <http://www.modbus.org>.
- [13] Muhammed Abdelati, "Syntheses of a Discrete Events System", the Second Conference of the Islamic University on Mathematical Sciences, IUG, Gaza, 27-28 August 2002.
- [14] www.plc-scada-dcs.blogspot.com