

Analytical study on strengthening of waffle slab with opening using CFRP sheets and stiffening ribs

Jeenu Mary Victor¹, Soni syed²

¹M. Tech Scholar, Dept. of Civil Engineering, KMEA Engineering college, Kerala, India

²Asst.Professor, Dept. of Civil Engineering, KMEA Engineering college, Kerala, India

Abstract - The waffle slab is a monolithic construction of flat flange plate and equally spaced ribs in orthogonal direction. Architects often deploy waffle slabs for the construction of large rooms such as conference halls, auditoriums, theatre halls etc. This slab offers more structural stability and strong foundation characteristics of crack and sagging resistance. It can hold greater amount of loads compared to traditional concrete slab. Openings provided in the floor slab of the buildings are for many purposes like stairs, elevators, and air conditioning ducts. But introducing openings in the slab can severely weaken the slabs due to cut of both concrete and reinforcing steel. In this study a non-linear static analysis is conducted to investigate the effectiveness of introducing ribs and CFRP sheets around the openings to strengthening the waffle slab with opening. The commercial FEM package ANSYS was selected for this study because of its wide acceptance, availability and fairly simple preprocessing interface.

Key Words: CFRP Sheets, Displacement, Finite element analysis, Openings, Ribs, Stress, Waffle slabs, Ultimate load

1. INTRODUCTION

Waffle slab is a very popular structural configuration often deployed in the construction of hotel porticos, airport terminal buildings, large banquet hall, convention centres and car parks. Void space formed in the underside of waffle slabs are utilized for architectural lighting. This type of slab has more structural stability without using a lot of additional material. This makes a waffle slab perfect for large flat areas like foundations or floors. Waffle foundations are resistant to cracking and sagging and can hold a much greater amount of weight than traditional concrete slabs. In almost all constructions slab system includes openings for multitude purposes like stairs, air conditioning ducts and elevators. And also the opening with smaller dimensions is needed to accommodate heating, plumbing, and ventilating risers, floor and roof drains, and access hatches. The behaviour of waffle slabs are modified by the presence of these openings. Introducing openings will reduce the strength of waffle slabs.

In this work, an attempt was made to study the strengthening methods of waffle slab with opening. In the present study waffle slab with opening was strengthened by using two methods, one is providing CFRP sheets around the opening [4] and another one is providing stiffening ribs

around the opening. The main aim of this study was to investigate the effect of introducing CFRP sheets and stiffening ribs around the openings to strengthening the waffle slab with opening. For this finite element models of waffle slab with opening, with CFRP sheets and stiffening ribs around the opening were modelled and analysed using ANSYS 14.5 software. The non-linear static analysis was conducted to compare the structural behaviour of waffle slabs with openings in terms of ultimate load carrying capacity, displacement and stresses due to effect of CFRP sheets and stiffening ribs around the openings.

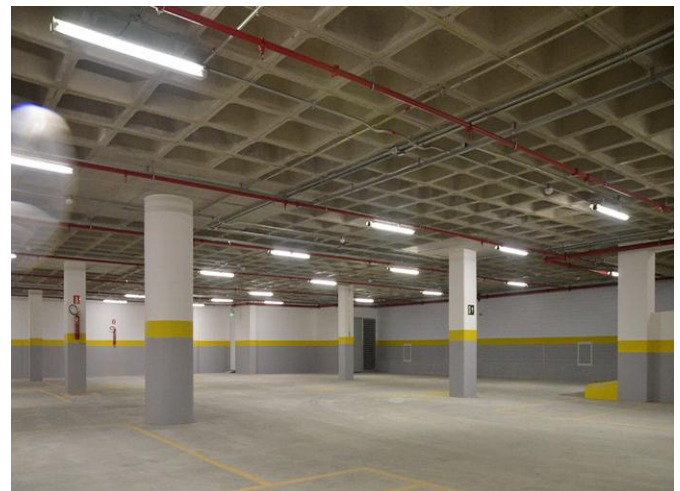

Fig-1: Waffle slab used in car parking area

2. DESCRIPTION OF THE WAFFLE SLAB MODEL

In order to study the structural behavior of waffle slabs, three waffle slab models are considered. General layout of Waffle slab model and reinforcement details are shown in figure 2. The waffle slabs are modeled using a scale ratio of 1:4, representing a real span of 6m. Overall dimension of waffle slab used are 1552 x 1552 mm, orthogonally spanning ribs have a dimension of 52x75mm and the ribs are placed at 300 mm center to center. The topping slab consisted of wire mesh of average diameter 0.7mm and mesh size 25mm at the middle of the slab. Ribs are reinforced with 8mm diameter rebar at a clear cover of 8mm. Material properties of waffle slabs used are shown in Table 1. Grade of concrete and steel used are M30 and Fe415 respectively. [3]

Opening size used is 500 x 500mm, shown in figure 3. In this case stiffening ribs just connect the cut ribs and are provided with same dimension as that of the waffle slab main ribs. In the case of waffle slab with CFRP sheets, these sheets are provided around the opening on the tension zone of the slab using an adhesive paste [4], shown in figure 3, and material properties of CFRP sheets are shown in Table 2. These sheets have 50 mm width and 0.131mm thickness.

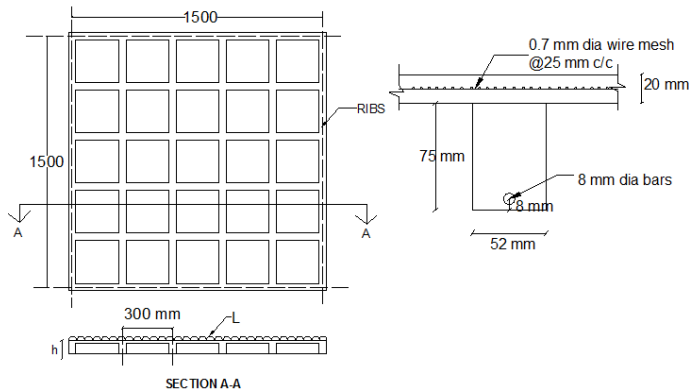

Fig-2 :General layout of waffle slab model and reinforcement details

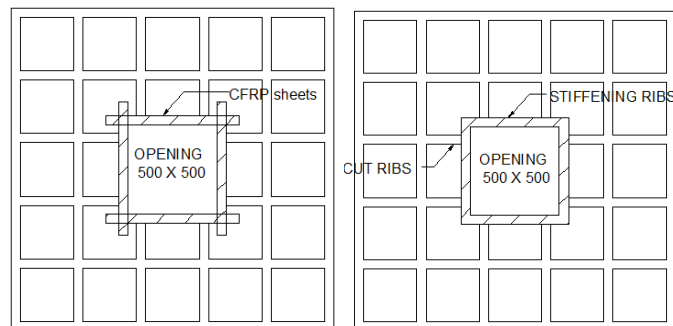

Fig- 3: Waffle slab model with CFRP sheets and stiffening ribs around the opening

Table-1: Material properties of waffle slab

Properties	Concrete	Steel
Modulus of elasticity, E (Mpa)	27386	200000
Poissons ratio, μ	0.2	0.3
Yield strength (N/mm ²)	-	415

Table-2: Material properties of CFRP sheets

Modulus of elasticity in x direction (Mpa)	E_x	2.3×10^5
Modulus of elasticity in y direction (Mpa)	E_y	1.79×10^4
Modulus of elasticity in z direction (Mpa)	E_z	1.79×10^4
Shear modulus in xy direction (Mpa)	G_{xy}	1.179×10^4
Shear modulus in xz direction (Mpa)	G_{xz}	1.179×10^4
Shear modulus in yz direction (Mpa)	G_{yz}	6.88×10^3
Poisson's ratio in xy direction	μ_{xy}	0.22
Poisson's ratio in xz direction	μ_{xz}	0.22
Poisson's ratio in yz direction	μ_{yz}	0.30

3. NUMERICAL ANALYSIS

One of the most common and powerful methods for analysis of waffle slabs is the finite element method (FEM). FEM is a numerical technique for finding approximate solutions to boundary value problems for partial differential equations. Finite element software ANSYS 14.5 was used in this study to investigate the effect of CFRP sheets and stiffening ribs around the opening. SOLID 65 element was used to model concrete, which is an eight- noded three dimensional solid element used for 3-D modelling of solid with or without reinforcing bars . This element has eight nodes with three degrees of freedom at each node – translations in the nodal x, y, and z directions. Reinforcement was modeled using LINK 180 element, which is a 3D spar element with three degrees of freedom at each node: translations in the nodal x, y, and z directions.

Slabs are fixed at all the edges. i.e., translations and rotations of X, Y, and Z directions are constrained. In this study modelling is done by using symmetrical boundary conditions at the two continues edges of waffle slab and pressure loads were applied on the top face of the slab. Non-Linear static analysis was conducted to determining the displacement, stresses, and ultimate load carrying capacity of waffle slabs. Finite element model of waffle slabs with loading and boundary conditions are shown in figure 4, 5 and 6.

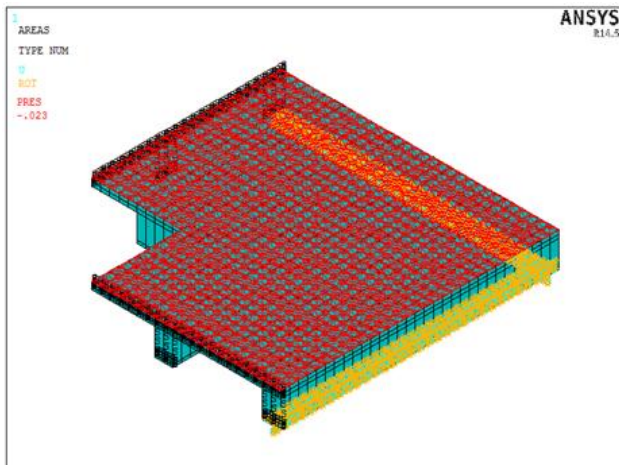

Fig- 4: FEM of waffle slab with opening

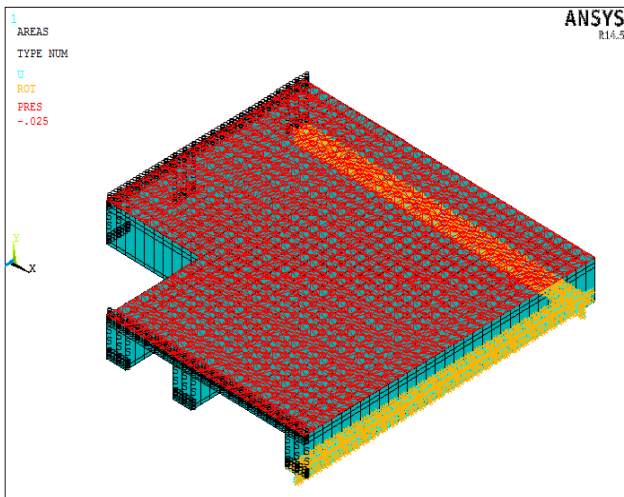

Fig-5: FEM of waffle slab with stiffening ribs

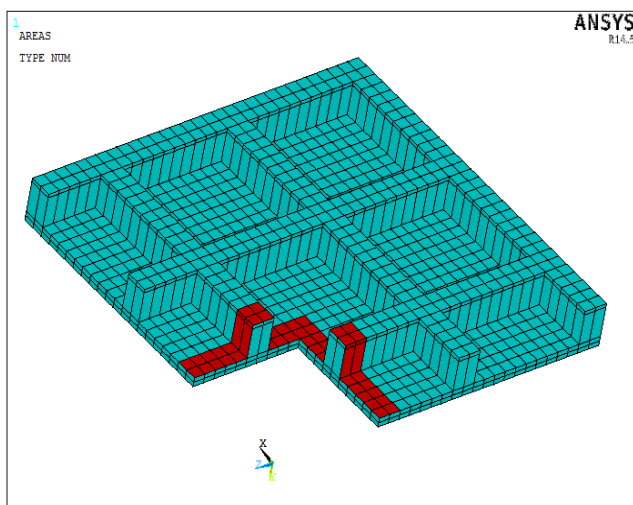

Fig-6: Bottom view of waffle slab with CFRP sheets

4. RESULT AND DISCUSSION

Here the ultimate load carrying capacity, displacement and stress of waffle slab models with opening, with CFRP sheets and stiffening ribs around the openings are compared. Table 3 shows the comparison of the ultimate load carrying capacities between the three slab models. And also the comparison between the load deflection curves of waffle slab with opening, with CFRP sheets and stiffening ribs around the opening are plotted, shown in figure 7.

Table-3: Comparison between the ultimate load carrying capacity

	With opening	With CFRP	With stiffening ribs
Ultimate load (KN/m ²)	23	23.9	25

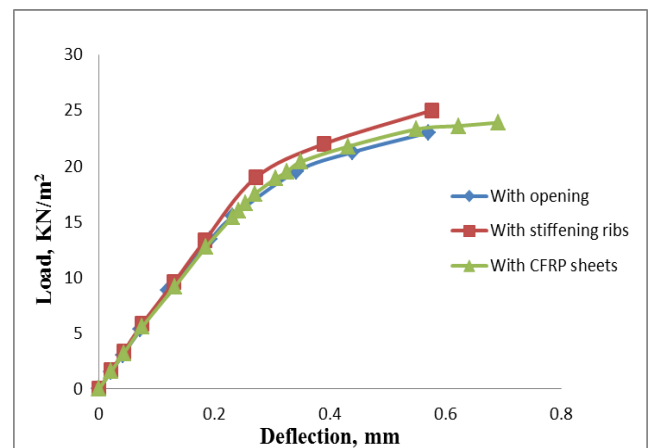

Fig-7: Comparison between the Load deflection curve

From the table 3 and figure 7, it can be seen that, introducing CFRP sheets and stiffening ribs around the opening can increase the ultimate load carrying capacity of waffle slab with opening. And the waffle slab with stiffening ribs has higher load carrying capacity compared to the waffle slab with CFRP sheets.

Displacement (Figure 8 to 10) and Von Mises stress (Figure 11 to 13) of three waffle slab models are compared by applied a same uniformly distributed load of 10, 15, and 20 KN/m² for each slab model shown in table 4 and comparison between the displacements and Von Mises stresses of three waffle slab models are shown in figures 14 and 15.

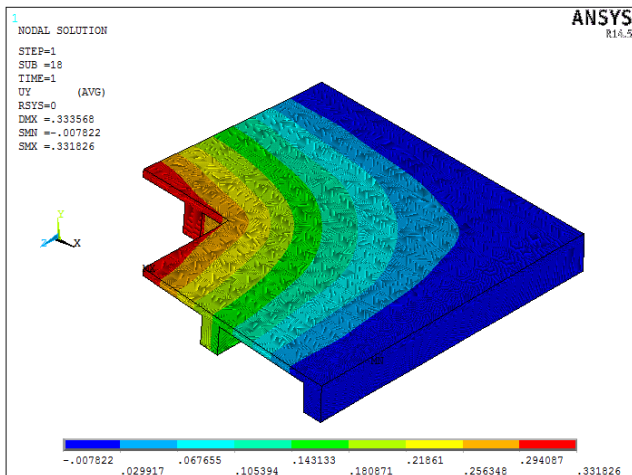

Fig-8: Displacement of waffle slab with opening corresponding to 15KN/m²

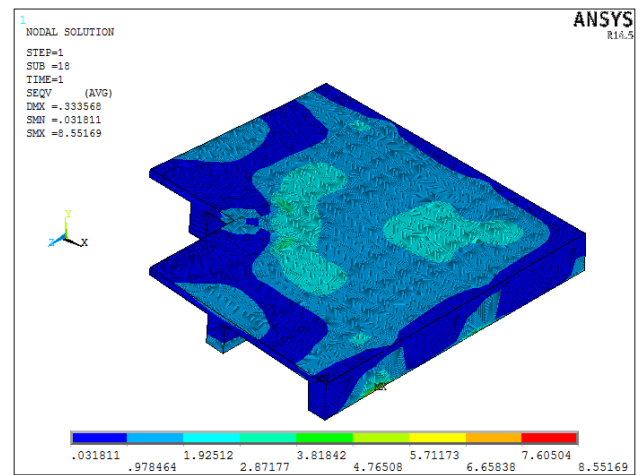

Fig-11: Von Mises stress of waffle slab with opening corresponding to 15KN/m²

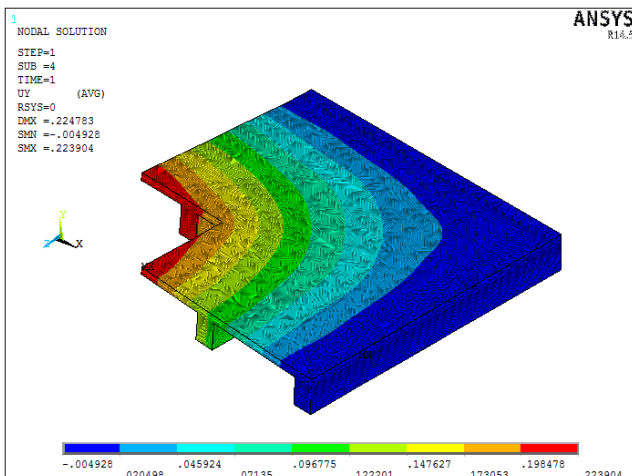

Fig-9: Displacement of waffle slab with CFRP sheets corresponding to 15KN/m²

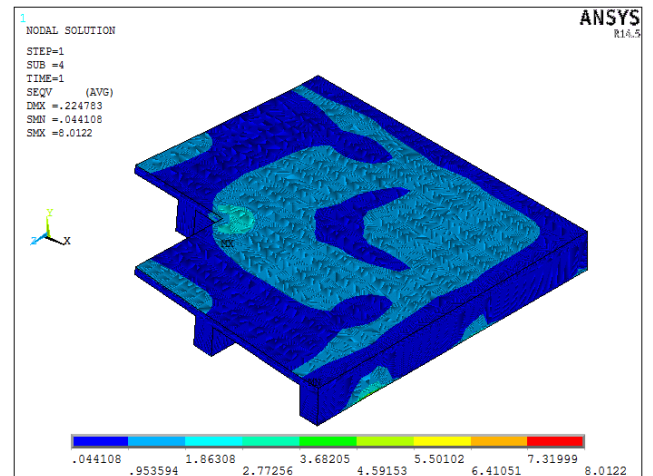

Fig-12: Von Mises stress of waffle slab with CFRP sheets corresponding to 15KN/m²

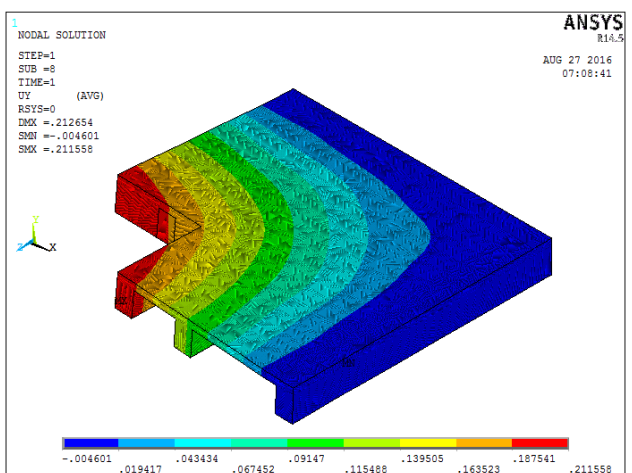

Fig-10: Displacement of waffle slab with Stiffening ribs corresponding to 15KN/m²

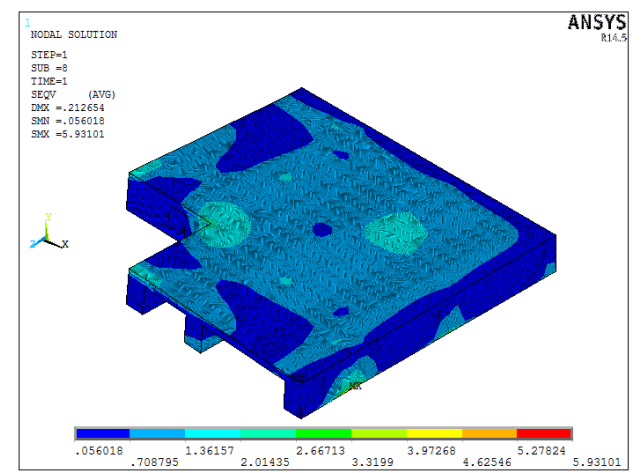

Fig-13: Von Mises stress of waffle slab with Stiffening ribs corresponding to 15KN/m²

Table-4: Displacement and stresses of three waffle slab models

Load (KN/m ²)	Displacement, mm			Stress, N/mm ²		
	S1	S2	S3	S1	S2	S3
10KN/m ²	0.18	0.14	0.14	5.40	4.93	3.74
15KN/m ²	0.33	0.22	0.21	8.55	8.01	5.93
20KN/m ²	0.38	0.35	0.28	10.01	9.59	8.27

Where S1 = Waffle slab with opening
 S2 = Waffle slab with CFRP sheets around the opening
 S3 = Waffle slab with stiffening ribs around the opening

Based on the values obtained from table 4, bar charts are plotted to compare the range and distribution of displacement and stresses of three waffle slab models.

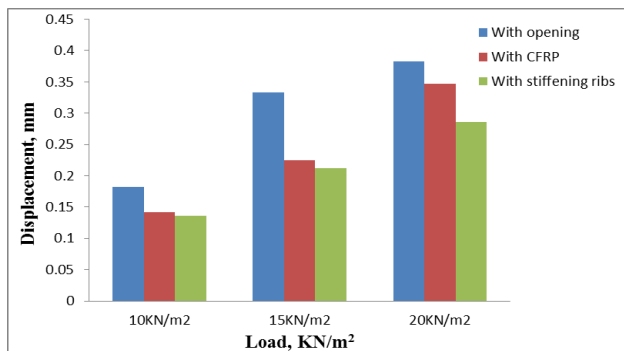

Fig-14: Comparison of displacement between three waffle slab models

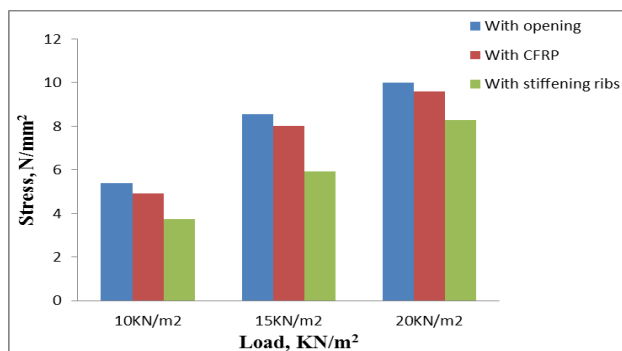

Fig-15: Comparison of Von Mises stress between three waffle slab models

From the figures 14 and 15, it is clear that the providing CFRP sheets and stiffening ribs around the opening can reduce deflection and stresses developed in the waffle slab

with opening. But compare to CFRP sheets, stiffening ribs around the opening has lesser deflection and stresses.

5. CONCLUSIONS

Waffle slabs have higher stiffness and smaller deflections and this slab are increasingly used in modern construction to reduce dead weight. Openings have to be provided in the floor slabs for many purposes like stairs, air conditioning ducts and elevators. Introducing openings in the slab can reduce the strength of the slab due to cut out of both concrete and reinforcement. In this study performance of CFRP sheets and stiffening ribs around the opening had been studied. A non- linear static analysis was performed, waffle slab with CFRP sheets and stiffening ribs around the opening showed very good behavior compared to the waffle slab with opening. The ultimate load carrying capacity of waffle slab with CFRP sheets and stiffening ribs around the opening are higher compared to the waffle slab without CFRP sheets and stiffening ribs. And the deflection and stresses developed in the waffle slab with opening can be reduced by providing CFRP sheets and stiffening ribs around the opening. But compared to CFRP sheets, stiffening ribs has higher load carrying capacity and lesser deflection and stress.

ACKNOWLEDGEMENT

First of all I thank The Almighty God who blessed me to deal with this topic. I take this opportunity to express my sincere thanks to Asst. Prof. Soni Syed Department of Civil Engineering, Mrs. Bindhu Sebastian ,Head of the department, Civil Engineering and Assoc.prof. Sunitha Rani C.M, M.Tech Coordinator, Department of Civil Engineering, KMEA Engineering College, Kerala, for their guidance, help, healthy co-operation and encouragement.

REFERENCES

- [1] Akinyele J. Olawale, "A Comparative Study on the Flexural Behavior of Waffle and Solid Slab Models When Subjected to Point Load", Journal of Civil Engineering and Architecture, Volume 8, May 2014.
- [2] Anjaly Somasekhar, "Analysis of Reinforced Concrete Waffle Slabs with Opening", International Journal of Emerging Technology and Advanced Engineering, Volume 5, Issue 9, September 2015.
- [3] Hashim M. S. Abdul-Wahab "Rigidity and Strength of Reinforced Concrete Waffle Slabs", Journal of Structural Engineering, Vol. 126, No. 2, February, 2000. @ASCE,2000.
- [4] Mustafa Basheer Mahmood, "Non-Linear Finite Element Analysis of RC Slabs Strengthened with CFRP Laminates", International Journal of Engineering Trends and Technology (IJETT) – volume 5 number 3- Nov 2013.
- [5] Sheetal Gawas, "Study on Two way RC Slab using ANSYS With and Without Central Opening", International journal of science engineering and technology, Volume No.3 Issue No.8, August 2014.