

# Design and Implementation of Real time location system using RFID and Xbee wireless Technology using ARM-7

B. S. Sonawane Sir, Mr. Mayur sonawane

Assistant professor, Dept. of E & Tc Engineering, SGDCOE Jalgaon, Maharashtra, India.

**Abstract**—in this paper, we propose a systematic approach to designing and Implementation of RFID Assisted Navigation System consists of active tags deployed on worker of company to provide navigation information while the RFID readers attached to the center of the hall the tag when passing by to obtain the data for navigation guidance. We analyze the design criteria of RFID and present the design of the RFID reader in detail to support Industries and will improve the work quality in industries. We also jointly consider the scheduling of the read attempts and the deployment of RFID tags based on the navigation requirements to support seamless navigations. The estimation of the person position and its accuracy are also investigated.

**Key Words:** RADIO Frequency Identification (RFID), Electronic Toll Collection (ETC), Real time location system (RTLS), matrix laboratory (MATLAB), Graphical user interface (GUI)

## 1. INTRODUCTION

RADIO Frequency Identification (RFID) has attracted considerable attentions in recent years for its broad applications in ubiquitous computing. In this paper, we propose a RFID based Real time location system (RFID-RTLS) for industries consists of RFID readers installed in companies and active RFID tags deployed on worker. As the maintenance for a active tag is easy and its cost is less

Than 3 dollar, it is feasible to deploy a large number of active tags for a relatively low cost over a broad area that is full of section and departments.

Intuitively, RFID complements to the current GPS navigation system when GPS signals are not available (such as in tunnels) or if the GPS position is ambiguous to a palace (such as at cloverleaf intersections). But in practice, GPS does not provide sufficient information for navigation due to its low positioning accuracy (5 to 7 meters). Moreover, even combined with map-matching technologies, GPS still cannot achieve lane level positioning and cannot provide information regarding the current position in industries where the worker has doing the work. Nevertheless, these information are necessary to prevent the worker from their responsibility when any one worker enter in another department then we can see easily that they are not

working their job right and we can also see that where they are

actually gone. RFID-RTLS is designed to address such problems. Its convenience and benefits give incentives for users to install RFID readers on their industries. Additionally, RFID-RTL Scan is configured to provide right location of any person. It might be essential to future autonomous systems as this system can provide more precise real time location information for industries and colleges. Note that the RFID reader attached at a department entrance side it is independent of the worker model, and it can be easily upgraded to guide manager. Therefore, RFID-RTLS could play an important role in the future complex industrial environment that contains autonomous, semiautonomous, and man-controlled system. RFID-RTLS is a ground navigation system that is designed for the industrial level navigation. The issues relevant to a practical RFID-RTLS in a complex industrial environment have never been addressed before. To our knowledge, this is the first work that provides a systematic approach to designing a RFID-RTLS. Our multi faceted contributions are stated as follows:

1) We provide an analysis on the design criteria of RFID-RTLS. These criteria serve as guidelines for the design of the RFID readers and the deployment of the RFID tags. We present the relationships among these design criteria, and investigate how they should be used cooperatively to achieve the objectives of the navigation system. Based on these criteria, we identify the parameters that are important

For the RFID-RTLS design.

2) We present the design of the RFID readers for RFID-RTLS in detail. The ranges of the critical parameters for the RFID readers are derived according to the requirements of the navigation system and the tag deployment.

3) We jointly consider the design of the RFID reader's read interval and the deployment of the RFID tags, such that the cost and energy consumption can be optimized as long as the requirements of the navigation system are satisfied. The proposed methods for read attempt scheduling and tag deployment are robust and adaptable to dynamic environments.

## 2. RELATED WORK

A RFID system is composed of RFID tags and RFID readers. A RFID tag stores data, and a RFID reader accesses the tag to collect the data through wireless communications. There exist two types of RFID tags: active tags, which contain power modules to support wireless communications, and passive tags, which power their transmissions through the energy absorbed from the radio waves of the RFID readers. Compared to active RFID tags, passive RFID tags are easier to maintain as they do not need power, and their cost can be as low as several cents. Therefore, passive RFID tags are more appropriate for applications that require a large number of tags. Traditionally, RFID tags were designed for commercial applications to replace the bar codes for asset counting [1], [2] and identification [3]. One important challenge in such applications is how to handle the read collision problem that occurs when one or more RFID readers query multiple RFID tags roughly simultaneously in a small area. As a result, most existing research focuses on anti-collision protocol design to schedule the reader's read requests and the tag's responses [4], [5], and [6]. In RFID-ANS, read collision is not possible as our design guarantees the one-to-one coupling of a RFID reader and a tag in a restricted area.

RFID systems have been deployed for VANETs, in which RFID tags are installed on vehicles while RFID readers are deployed on stationary infrastructures. For example, in a typical Electronic Toll Collection (ETC) system [7], automatic toll RFID readers are installed at the gate. A RFID tag (attached to the E-Z Pass on a vehicle) is read by the reader when a vehicle passes by the gateway. The toll system identifies the vehicle through the data obtained from the RFID tag, and automatically charges to the vehicle's or the driver's account. A similar system is established for parking fee collection in [8]. Compared to these systems, RFID-ANS contains stationary tags on roads while readers move with vehicles at high speeds. The most related work to RFID-RTLS are reported in [9], [10], and [11]. Chon et al. [9] propose the idea of using stationary RFID tags deployed on roads to localize vehicles when passing by. The feasibility of utilizing RFID tags for navigation when vehicles move at high speeds is investigated through an experiment in which a RFID reader reads the data in a tag when the tag is dropped down to the ground. Lee et al. [10] study the relationship between the tag read latency and the vehicle's speed, and evaluates their results on a test road. These two works demonstrate the feasibility and practicality of applying commercial RFID tags and readers in the vehicular environment. But none of them considers critical issues such as tag deployment and read scheduling, which are important to the design of a practical RFID-ANS as they mainly focus on the concept and feasibility study. In the Road Beacon System proposed in [11], RFID tags serving as traffic signs are deployed in the pavement and vehicles get the road

information through reading the tags. The technical details of this work are unavailable to our best knowledge

## 3. PROPOSED SYSTEM

In this system we will show the demo of three sections in the company for example if we consider a production industry.

- 1) R&D department
- 2) Production
- 3) Quality check.

This system traces exact location of every registered person in industry. For example suppose A- series of Tags are allotted to the labors who works in R &D department, B series allotted to the labors who works in production and C series allotted for the labors who works in Quality control department As shown in Monitor section.

RFID trans-receiver placed in industry at particular distance. Service area of single RFID trans-receiver is known as cell. All the RFID Tags which present in a cell detect by that RFID trans-receiver due to which location of that tags displayed on monitor. If in each dept. one RFID trans-receiver mounted then location of all tags which present in there range indicated on the monitor.

If any person moves from his department then his tag leave the previous cell and enter into a new cell that means in service area of another RFID trans-receiver therefore change in location of that tag detected and a real time location indicated on monitor

For interfacing of hardware section with PC we can use the arm-7 processor and Zigbee device. Signal received from trans-receiver given to the zigbee through arm processor the output of Zigbee connect with the PC. We can design a GUI by using MATLAB. This software works on the receiving signal and indicates the current location of each tag on monitor screen.

**Table -1:** Component list table

Department	Component1	Component2	Component3	Component4	Component5
R&D	ARM-7	ZigBee	RFID Rx	Tags	
Production	ARM-7	ZigBee	RFID Rx	Tags	
Q&C	ARM-7	ZigBee	RFID Rx	Tags	
monitor	ARM-7	ZigBee	RFID Tx	Matlab	PC

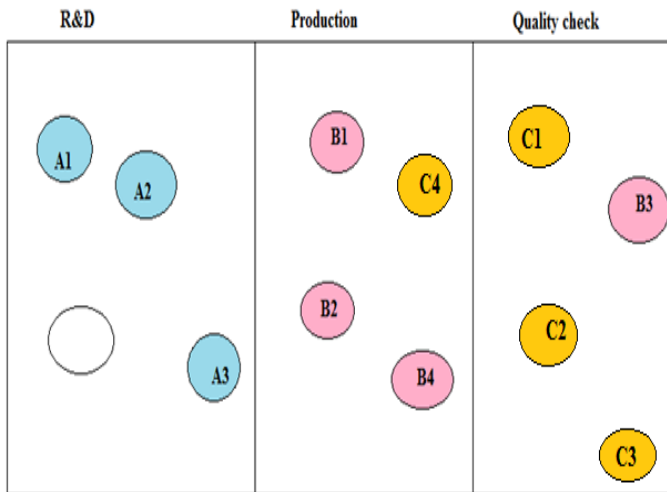

Fig -1: Monitor section (Matlab GUI representation)

Here we have consider that

A1, A2, A3, A4 are the worker of R&D section.

B1, B2, B3, B4 are the worker of production section.

C1, C2, C3, C4 are the worker of Quality check section.

The GUI shows that

A1, A2, A3 is present in their unit but A4 is absent.

B1, B2, B4 is present in their section but B3 is gone to Quality check section.

C1, C2, C3 is working and present in their section but C4 is gone to the production department.

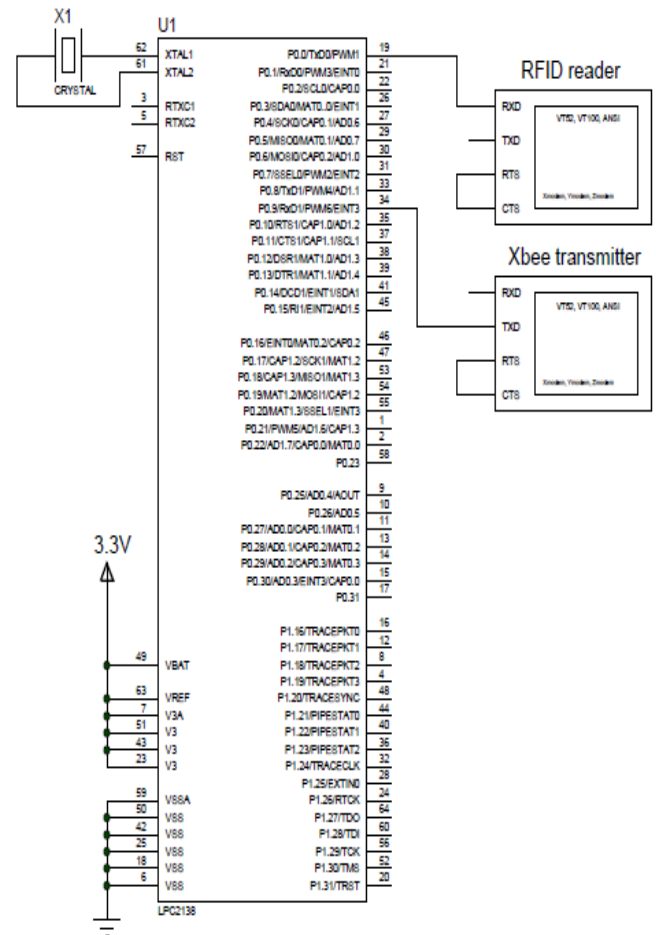

Fig -2: Circuit diagram of receiver section

#### 4. CONCLUSION

In this paper, we have proposed newly fashioned real time locating system using active RFID for detection of real time location of person in indoor environment i.e. the iLocate system for the lot. To eliminate the RFID RSSI noise, iLocate employed the frequency hopping technique. To achieve the fine-grained localization accuracy, it looks advantage of the virtual reference tags and tag-tag communication protocol. To support a large scale RFID network iLocate used Sigsbee.

#### 5. REFERENCES

[1] H. Han, B. Sheng, C.C. Tan, Q. Li, W. Mao, and S. Lu, "Counting Rfid Tags Efficiently and Anonymously," Proc. IEEE INFOCOM'10, Mar. 2010.

[2] M. Kodialam and T. Nandagopal, "Fast and Reliable Estimation Schemes in Rfid Systems," Proc. MobiCom '06, pp. 322-333, 2006.

[3] L.Xie, B. Sheng, C.C. Tan, Q. Li, and D. Chen, "Efficient Tag Identification in Mobile Rfid Systems," Proc. IEEE INFOCOM '10, Mar. 2010.

- [4] B. Metcalfe, "Steady-State Analysis of a Slotted and Controlled Aloha System with Blocking," SIGCOMM Computer Comm. Rev., vol. 5, no. 1, pp. 24-31, 1975.
- [5] S.-R. Lee, S.-D. Joo, and C.-W. Lee, "An Enhanced Dynamic Framed Slotted Aloha Algorithm for Rfid Tag Identification," Proc. the Second Ann. Int'l Conf. Mobile and Ubiquitous Systems: Networking and Services (MOBIQUITOUS '05), pp. 166-174, 2005.
- [6] J. Myung and W. Lee, "Adaptive Splitting Protocols for Rfid Tag Collision Arbitration," Proc. Seventh ACM Int'l Symp. Mobile Ad Hoc Networking and Computing (MobiHoc '06), pp. 202-213, 2006.
- [7] E-zpass, <http://www.e-zpassny.com>, 2010.
- [8] Z. Pala and N. Inanc, "Smart Parking Applications Using Rfid Technology," Proc. First Ann. RFID Eurasia, 2007.
- [9] H.D. Chon, S. Jun, H. Jung, and S.W. An, "Using Rfid for Accurate Positioning," J. Global Positioning Systems, vol. 3, nos. 1/2, pp. 32-39, 2004.
- [10] E.-K. Lee, Y.M. Yoo, C.G. Park, M. Kim, and M. Gerla, "Installation and Evaluation of Rfid Readers on Moving Vehicles," Proc. ACM Sixth Int'l Workshop Vehicular InterNetworking (VANET '09), pp. 99-108, Sept. 2009.
- [11] Road Beacon System, <http://www.roadbeacon.com/>, 2010.

## BIOGRAPHIES



Assistant professor,  
Dept. of E & Tc Engineering,  
SGDCOE Jalgaon, Maharashtra,  
India.



Student Of M.E. (E & Tc)  
Dept. E & Tc Engineering  
SGDCOE Jalgaon,  
Maharashtra, INDIA