

Control Strategy for a cross phase connected and a conventional UPQC

Anupam Ojha¹, Amit Solanki², Rakesh Singh Lodhi³, Prinkesh Soni⁴

PG Scholar¹, Associate Professor², Associate Professor³, Assistant Professor⁴

Department of Electrical and Electronics Engineering, Oriental University, Indore (M.P.) India

ABSTRACT - A three-phase unified power quality conditioner (UPQC) with cross-phase connection is investigated. The UPQC is designed to mitigate voltage sags/swells, including those resulting from single-phase faults. Based on an analysis of the configuration of the conditioner, multi-loop control schemes are proposed for the voltage and current compensation strategies. The results demonstrate the proposed control strategy for the cross-phase-connected UPQC is capable of regulating load terminal voltage and compensating load current changes simultaneously and effectively.

UPQC has been modeled for both active and reactive power compensation using different control strategies. The behavior of UPQC has been analyzed with sudden switching of R-L loads, as well as occurrences of different shunt faults. The control scheme has been devised using PI controller in UPQC operation in case of switching and faults in transmission systems.

Key Words: Power quality, Harmonics, VSC

1 INTRODUCTION

A Unified Power Quality Conditioner (UPQC) is a relatively new member of the custom power device family. It is a combination of shunt active filter and series active filter. The concept of UPQC was first introduced in 1996. It is speculated that almost any power quality issues can be tackled with this device. Generally power quality problems arise either because of supply voltage distortion or because of load current distortion. Since a UPQC has both series and shunt compensators, it can handle supply voltage and load current problems simultaneously when installed at the point of common coupling. It can protect sensitive loads from power quality events arising from the utility side and at the same time can stop the disturbance being injected in to the utility from load side. A UPQC is a device that is similar in construction to a Unified Power Flow Conditioner (UPFC). The UPQC, just as in a UPFC, employs two voltage source inverters having a common DC energy storage capacitor. One of these two VSIs is connected in shunt with the AC system while the other is in series with AC line. As similar to UPFC, UPQC also performs shunt and series compensation in a power distribution system. Since a power transmission line generally operates in a balanced, distortion (harmonic) free environment, a UPFC must only provide balanced

shunt or series compensation. A power distribution system, on the other hand, may contain unbalance, distortion and even DC components. The power electronic devices due to their inherent non-linearity draw harmonic and reactive power from the supply. In three phase systems, they could also cause unbalance and draw excessive neutral currents. The injected harmonics, reactive power burden, unbalance, and excessive neutral currents cause low system efficiency and poor power factor. In addition to this, the power system is subjected to various transients like voltage sags, swells, flickers etc. These transients would affect the voltage at distribution levels. Excessive reactive power of loads would increase the generating capacity of generating stations and increase the transmission losses in lines.

2 PRELIMINARY ANALYSIS

The cross-phase-connected UPQC can be installed at the point of common coupling (PCC) on distribution systems where critical/sensitive loads are present. Note that with this circuit structure, each of the three UPQC modules is cross-phase-connected at the load-side. Each module consists of a series and a parallel half-bridge VSCs and the two VSCs share two split-capacitors, the midpoint of the DC-link capacitors is connected to the distribution feeder directly. As stated earlier, unlike the conventional UPQC design, no injection transformer is needed in the new design. In this section, the UPQC modelling has been presented considering the equivalent circuit of UPQC. The dq transformation, compensation strategy, basic control function, series and shunt converter controls have been explained for UPQC model development

2.1 FOR A CROSS PHASE CONNECTED UPQC

The general operating principle of the proposed UPQC can be explained as follows. By controlling the voltages v_{ca1} , v_{cb1} and v_{cc1} across the filter capacitors (each denoted as C1), the series VSCs are capable of both rapid mitigation of the effects of supplied-side steady-state voltage imbalance and voltage sag/swell. The technique to achieve these functions will be described in the next section. Furthermore, in each phase, the passive filter formed by the filter inductor (L1) and C1 can remove the switching frequency harmonics which appear at the output voltages of the series VSC. Also, it would be shown that with the control of the current through the filter inductor L2, the parallel VSCs can mitigate the level of harmonics and

compensate for the imbalance and reactive components in the supply-side currents because of the imbalance and/or distortions in the load currents i_{La} , i_{Lb} and i_{Lc} . Moreover, the VSC draws fundamental currents from the load terminal so as to maintain the DC-link voltages at nominal level during the operation of the series VSCs. In the event of the occurrence of supply-side voltage imbalance and/or voltage sag/swell, both the series and parallel VSCs will be activated. The series VSCs inject a set of three-phase voltages to regulate the load terminal voltage to pre-set magnitude and phase, whereas the parallel VSCs regulate the DC-link voltage. Thus, the loads will not be affected by the supply-side disturbances.

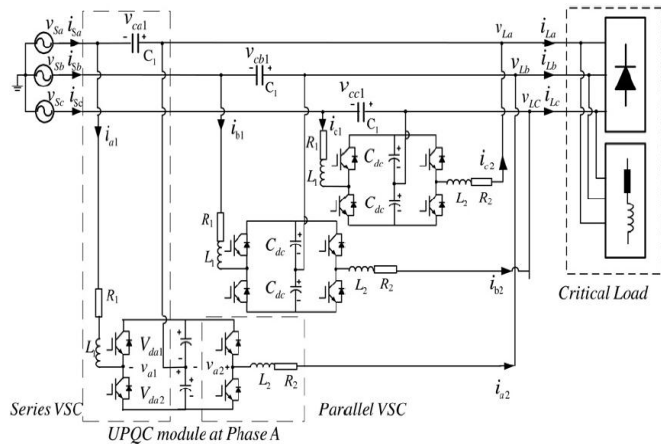

Figure 2.1 Circuit diagram of a cross-phase connected UPQC

Under normal condition, the UPQC would not be expected to function and therefore the IGBTs of the half-bridges will be off. Hence, no line-line short circuit would occur across the phases. Under disturbance condition, the UPQC operates with the IGBT switching at high frequency, typically at some 5 kHz. The duration of the remaining 'ON' time when either the top or bottom pair of the IGBTs of one of the half-bridges is concurrently turned on is very short. Thus, this type of short-circuit occurrence can be ignored.

2.2 FOR A CONVENTIONAL UPQC

2.2.1 Modeling of UPQC

The simplified diagram of UPQC with series and shunt active filters has been shown in Figure 1. The UPQC modelling has been presented considering the equivalent circuit of UPQC. The factors that have been explained for UPQC model development are-

- The dq transformation.
- Compensation strategy.
- Basic control function.
- Series converter controls.
- Shunt converter controls.

2.2.2 CIRCUIT DIAGRAM

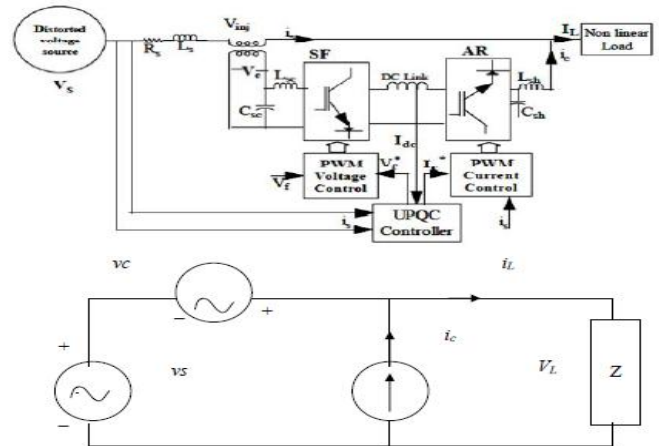

Figure 2.2 Simplified UPQC Diagram & Equivalent Circuit Diagram of UPQC

, v_s is the supply voltage. V_c , I_c are the series compensation voltage, shunt compensation current and v_L , i_L are the load voltage and current respectively. The source voltage may contain negative, zero as well as harmonic components.

Where v_{1pa} is the fundamental frequency positive sequence components, v_{1na} is fundamental frequency negative sequence components respectively. V_{1p} is the positive sequence voltage amplitude and V_{1n} is the negative sequence voltage amplitude. The last term of equation represents the harmonic content in the voltage. In order for the load voltage to be perfectly sinusoidal and balanced, the series filter should produce a voltage of:

3. CONTROL SCHEMES.

3.1 For a cross phase connected UPQC.

3.1.1 UPQC Series VSC Control Scheme.

3.1.1.1 Generation of compensation voltage reference signal.

The primary objective of the series VSC is to inject a set of three-phase voltages, denoted by v_{ca1} , v_{cb1} and v_{cc1} , so as to regulate the load terminal voltage to pre-set magnitude and phase, in the event of voltage imbalance and/or sag/swell in the supply side. In the three-phase three-wire system, it can be assumed that the supply voltages v_{Sa} , v_{Sb} and v_{Sc} , contain positive and negative phase sequence components defined by

$$\begin{bmatrix} V_{Sa} \\ V_{Sb} \\ V_{Sc} \end{bmatrix} = V_{sp} \begin{bmatrix} \cos(\omega t + \theta p) \\ \cos(\omega t - \frac{2\pi}{3} + \theta p) \\ \cos(\omega t + \frac{2\pi}{3} + \theta p) \end{bmatrix} + V_{sn} \begin{bmatrix} \cos(\omega t + \theta n) \\ \cos(\omega t + \frac{2\pi}{3} + \theta n) \\ \cos(\omega t - \frac{2\pi}{3} + \theta n) \end{bmatrix}$$

give output. The control strategy uses a PLL based unit vector template for extraction of reference signal from the distorted input supply. The block diagram of extraction of unit vector template is as given

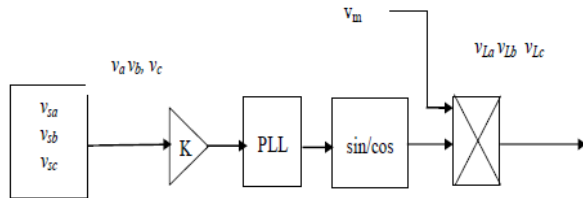

Figure 3.3.3 Extraction of Unit Vector Template

The input source voltage at point of common coupling contains fundamental and distorted component. To get unit vector templates of voltage, the input voltage is sensed and multiplied by gain equal to $1/v_m$, where v_m is peak amplitude of fundamental input voltage. These unit vector templates are then passed through a PLL for synchronization of signals.

4 SIMULATION & RESULTS.

The simulations and the results are divided into two parts. The first part contains the simulation diagrams of the cross phase conned unified power quality conditioner, where the second part contains simulations and results for a conventional unified power quality conditioner. For both the parts the simulations and results are being carried out in MATLAB version 7.8.0 (R2009A). The model is initially considered with STATCOM and then without STATCOM and with & without UPFC model with a variables load states of linear and nonlinear loads consideration, the results are obtained in this section and discussion in carried out. In case load block, they are absorbing 50 W real and 500 VAR reactive power having value of voltage 110 Volts.

4.1 FOR A CROSS PHASE CONNECTED COMBINED SERIES & PARALLEL VSC CONTROLLERS.

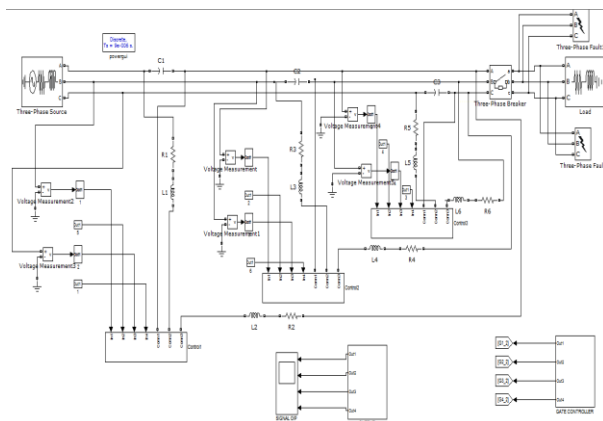

Figure.4.1 Simulation diagram of Cross-phase connected UPQC with both series & parallel VSC controller.

4.1.1 RESULTS

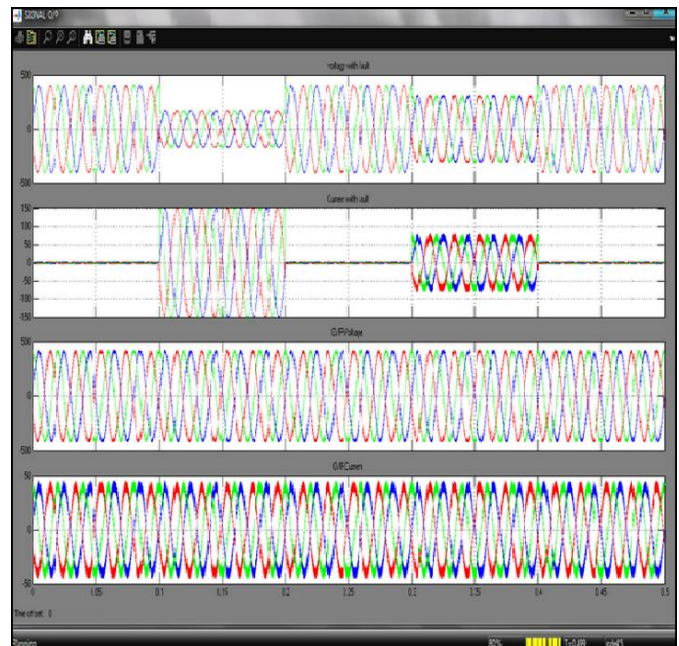

Figure.4.1.1 Waveforms of voltage and current with UPQC compensation in steady state

- a) Voltage with fault (b) Current with fault
- c) Output voltage (d) Output current

4.2 FOR A CONVENTIONAL UPQC.

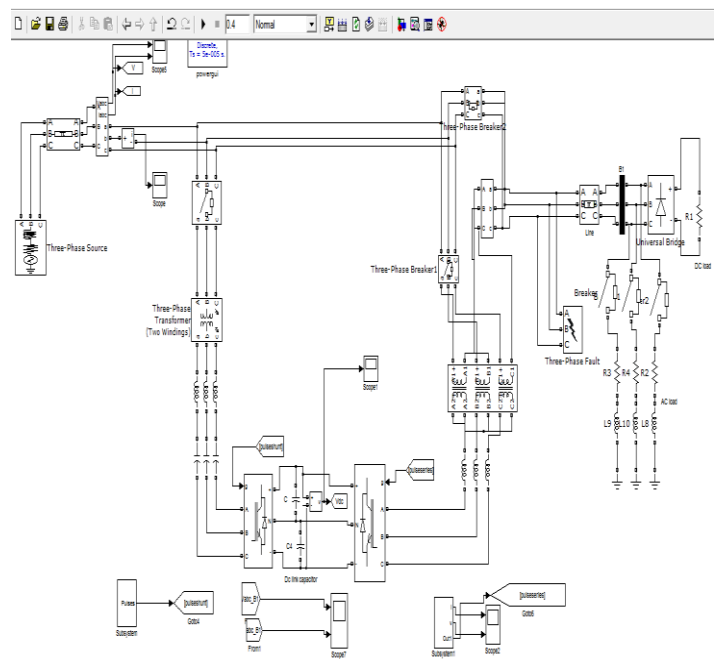

Figure.4.2 Simulink Model Of UPQC

4.2.1 Voltage and current before compensation.

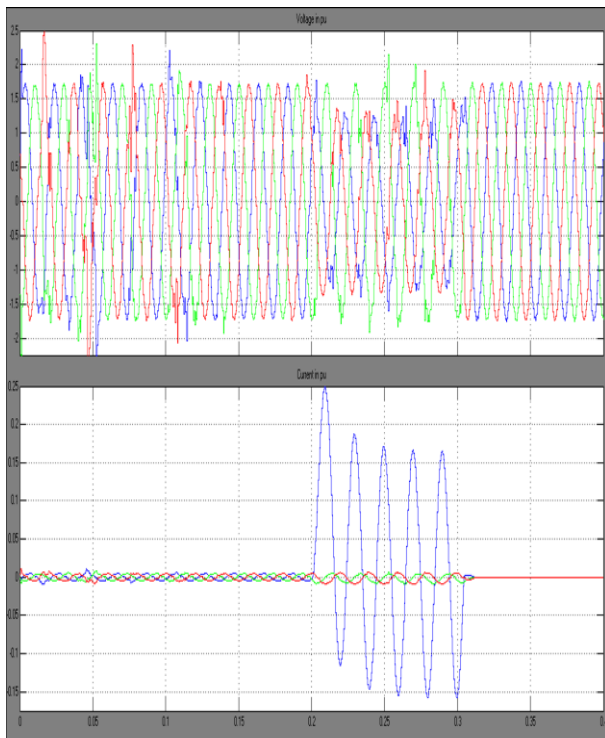

Figure 4.2.1 Voltage and Current before Compensation.

4.2.2 DQ components through PLL .

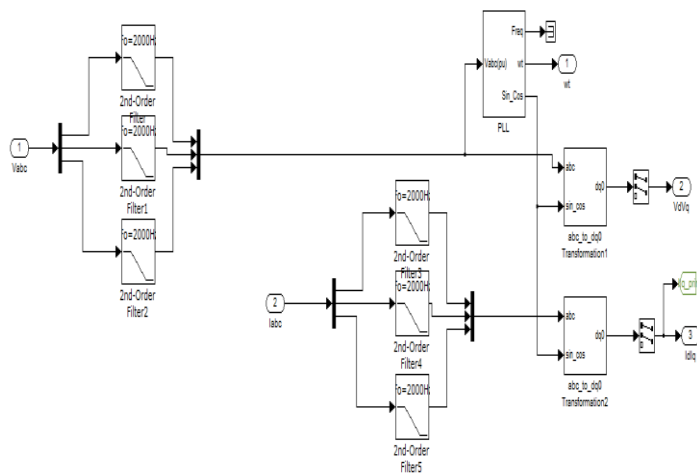

Figure 4.2.2 Simulation diagram of PLL Block of shunt Converter Control.

4.2.3 Series Converter Control (Pulses Generation).

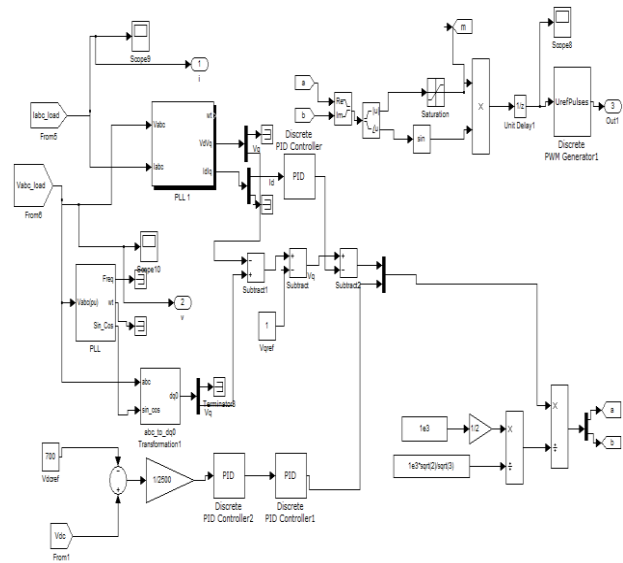

Figure 4.2.3 Simulation Diagram for Series Converter Control.

4.3 RESULT

4.3.1 After Compensation

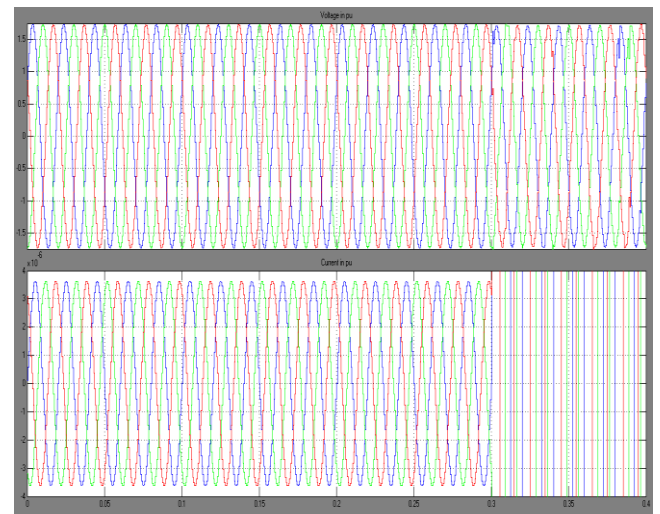

Figure 4.3.1 Voltage and Current After Compensation

When the transmission line is without UPQC, the real and reactive power flow cannot be controlled under non-linear loads and sudden change in their values. Transmission line capability of the existing transmission line is highly improved with the presence of UPQC. The difference between the sending-end real power and receiving end real power is high in the transmission line without UPQC. This is due to the increase in transmission losses, which are minimized with the help of UPQC. The power transfer capability of long transmission lines is usually limited by their thermal capability. Utilizing the existing transmission line at its maximum thermal capability is possible with UPQC. The series inverter injects voltage of variable magnitude and phase into the transmission line at the

point of its connection, there by controlling real and reactive power flow through the line. The active power through the line active power. This real power is obtained from the dc source connected to its dc terminals. The shunt inverter provides the required power to the series inverter through the dc link. For unbalanced condition extra RL load at dc side of the capacitor is connected. Unbalance is created by switching RL load on the ac side of the diode rectifier on phase another RL load at phase b and phase c connected respectively.

5 CONCLUSIONS

5.1 For a Cross Phase Connected UPQC.

The topology of a cross-phase-connected UPQC is introduced and two multi-loop control schemes are incorporated for the series and parallel VSC within the proposed UPQC. Extensive simulations are carried out to verify the practicability of the configuration and the effectiveness of the proposed control schemes under various operating conditions. It has been shown that the new control strategy for the UPQC is capable of protecting critical loads against voltage deviations, such as voltage imbalance, three-phase voltage sag/swell. Also the UPQC with the proposed control can regulate the currents

5.2 For a Conventional UPQC.

The control and performance of UPQC intended for installation on a transmission line. The performance of UPQC has been studied under different cases of R-L, R-C loads switching and different kind of shunt faults. Simulation results show the effectiveness of UPQC in active filtering and controlling real and reactive power through the line. AC voltage regulation and power factor of the transmission line is also improved. The UPQC provides an improvement in the real and reactive power flow through the transmission line. UPQC provides reliable performance in switching of loads as well as different types of shunt faults.

6 FUTURE WORKS

In particular, it should be emphasized that the proposed control strategy for the cross-phase-connected UPQC can compensate for single-phase voltage sags of up to 100%, the capability of being able to do so is not limited by the sag duration. This is because of the UPQC cross-phase configuration.

Some fundamental development of modeling and control of the UPQC has been made and the results of study have confirmed that the approaches proposed in this thesis are well suited to practical system planning and operations. However, as being a new technology, development, research and application of the UPQC are just in an infant period and some important issues are still open for researchers to do further work so as to best apply the UPQC.

REFERENCES.

- [1] IEEE standard 519-1992, IEEE recommended practices and requirement for harmonic control in electrical power systems, IEEE, Inc. 1993.
- [2] L. Gyugi, R. A. Otto, and T. H. Putman, "Principles and application of static, thyristor controlled shunt compensators," IEEE Trans. on Power Apparatus and Systems, vol. PAS-97, pp. 1935-1945, sept./oct. 1978.
- [3] L. Gyugi, "Reactive power generation and control by thyristor circuit," IEEE Trans. Industrial Applications, pp. 1935- 1945, sept/oct 1979.
- [4] L. Gyugyi and E. C. Strycula, "Active ac power filters," in Proc. 1976 IEEE/IAS Annual Meeting, 1976, pp. 529-535.
- [5] L. Gyugi, "Unified power flow control concept For flexible ac transmission system," IEE proc.-C, vol. 139, no. 4, July 92, pp 323-332.
- [6] H. Akagi, "Performance and modeling of a shunt active filter for Installation on power distribution systems," to be presented at the 1996 IEEE-PES International Conference on Harmonics and Quality of Power, Oct. 16-18, 1996.
- [7] N.G Hingorani, "High power electronics and flexible ac transmission systems" IEEE. Power Engineering Review, July 1988.
- [8] L. Gyugyi, etal, "The unified power flow controller a new approach for Transmission control " IEEE Trans. Power System, 94 SM 474-7 PWRD.
- [9] K.K. Sen, E.J. Stacey, "UPFC - theory, modeling, and application", PE-282- PWR-0-12-1997, IEEE PES Winter Meeting, Tamp, FL.
- [10] H. Fujita and H. Akagi, "The unified power quality conditioner: The Integration of series- and shunt active filters," IEEE Trans. Power Electronics, vol. 13, no. 2, pp. 3 15-322, 1998.
- [11] H. Fujita and H. Akagi, "The unified power quality conditioner: The integration of series- and shunt active filters," IEEE Trans. Power Electronics, vol. 13, No. 2, pp. 3 15-322, 1998.
- [12] H. Akagi, Y. Kanazawa, and A. Nabae, "Instantaneous reactive power compensators comprising switching devices without energy storage components," IEEE Trans. Ind. App., vol. IA-20, pp. 625-30, May/June 1984.
- [13] Elmitwally, S. Abdelkader, and M. EL-Kateb, "Neural network controlled three-phase four-wire shunt active power filter", IEE Proc.- Gener. Trans. Distr., March, vol. 147, No. 2, 2000.
- [14] Zouidi, F. Fnaiech, and K. AL-Haddad, "Neural network controlled three-phase three-wire shunt active power filter", Proceedings of IEEE ISIE, July 9-12, Montreal Quebec, Canada, 2006, pp.5-10.
- [15] J. R. Vazquez, and P. R. Salmern, (2000) "Three-phase active power filter control using neural networks", Proceedings of 10th Mediterranean Electro Technical Conference, MEleCon, vol. 3, pp.924- 927.
- [16] E. H. Watanabe, R. M. Stephen, and M. Arcdes, "New concept of instantaneous active and reactive powers in electric systems with generic load," IEEE Trans. on power delivery, vol.8, April 1993, pp. 697-703.
- [17] M. Arcedes and E.H. Watanabe, "New control algorithms for series and shunt three-phase four wire

active filter," IEEE Trans. on power delivery, vol.10 pp. 1649-1656, July 1995.

[18] R. Rezaipour and A. Kazemi, "Review of novel control strategy for UPQC International journal of electrical and power engineering vol 2(3): p.p 185-195, 2008.

[19] M. M Morcos, J.C.Gomez, "Electric power quality – the strong connection with power electronics", Power and Energy Magazine, IEEE, Volume:1, Issue:5, Sep- Oct 2003, pp. 18-25.

[20] B. Singh, K. Al-Haddad, A. Chandra, "A Review of Active Power Filters for power quality Improvement", IEEE Trans on Industrial Electronics, Vol 45, No.5, Oct 1999, pp. 960-971.

[21] C.J.Msigwa, Beda J .Kundy and Bakari M.M Mwinyiwiwa, "Control algorithm for Shunt active power filter using synchronous Reference Frame Theory".

[22] J. Turunen, H. Tuusa, "Improvement of the voltage compensation performance of the series active power filter using a simple PI control method" IEEE Proceedings on Power Electronics and Applications, 2007 p.p 1-9.

BIOGRAPHIES



Anupam Ojha is a PG Scholar, department of electrical & electronics engineering at Oriental University, Indore (M.P.). He is working on new research of Facts Devices for Power Quality Improvement.



Amit Solanki is Associate Professor, department of electrical & electronics engineering at Oriental University, Indore (M.P.). He is in academics and research from last nine years and has guided research projects on post graduate level.



Rakesh Singh Lodhi is Associate Professor, department of electrical & electronics engineering at Oriental University, Indore (M.P.). He is in academics and research from last eight years and has guided research projects on post graduate level. He is also working in new research areas such as Cuk converter, PV system.



Prinkesh Soni is a PG Scholar, department of electrical & electronics engineering at Oriental University, Indore (M.P.). He is working on new research of Solar Energy System.