

# Design of two stage transmission system for one-wheeled motorcycle

Dr. K. K. Dhande<sup>1</sup>, Vipul A. Mhaske<sup>2</sup>

<sup>1</sup>Head, Mechanical engineering dept. DYPIET Pune, Maharashtra, India

<sup>2</sup> P.G. Student, Mechanical engineering dept. DYPIET Pune, Maharashtra, India

\*\*\*

**Abstract** - Essential drive requires only motor and set of sprockets to transmit the power from motor to wheel, based on available space to implement transmission system in one-wheeled motorcycle with available torque and desired maximum speed, reduction ratio is large so it's not possible to implement single stage transmission for this two-stage transmission system is designed. This reduces the size of components. By splitting transmission into two stages, increases the overall complexity but reduces the component sizes, as it is more critical factor in system than minimizing the number of parts. This design also decreases the total weight of overall system.

**Key Words:** transmission, one-wheeled, motorcycle, two-stage, jackshaft.

## 1. INTRODUCTION

Considering the parking space issue in urban areas there is immense necessity of developing compact transportation system which has small longitudinal length, for this developing of one-wheeled motorcycle is done. One-wheeled motorcycle can overcome parking space issue as it has less longitudinal length and further advantage of less carbon footprint. Design of effective transmission is very essential for appropriate performance of any system. The transmission is designed in such a way that it should properly acquitted within the available space. The system in which transmission is to be utilized consist of less space. Based on desired maximum speed and required torque at wheel from motor reduction stage is utilised. The single stage drive is more preferable, but for the required desired speed and limited space available the component sizes required for the reduction are larger and which does not fit in available space. So two-stage transmission is designed and implemented for the system. Two-stage transmission reduces the component sizes and overall weight so that it can be effectively implemented in the available system such a that it performs to get desired results. Two-stage transmission system consist of

1. primary stage
2. Intermediate stage
3. secondary stage

For designing primary stage and secondary stage main factor which affects selection is maximum HP calculations, gear reduction from motor to jackshaft, centre to centre distance between drives and service factor to ensure durability and intermediate stage consist of Jackshaft. It is simply a shaft which connects two stages of a power transmission (High

speed-low torque & low speed – high torque). The shaft needs to be supported by bearings at each end of the drive. Therefore, one bearing would be near the driven pulley of primary stage and the other placed near the driving pulley of secondary stage. Components required to design two-stage transmission system are Drives, Pulleys, Jackshaft and Bearings as per the required speed and gear reduction ratio. Important consideration while designing two-stage transmission system is that it should be able to perform effectively as per the desired results with less vibration and maintenance and easily fitted into available space.

## 2. Selecting Speed and Gear reduction

For desired top speed of between 20 km/hr to 25 km/hr, design of overall transmission system for a gear ratio from the motor shaft to the wheel of 1 (drive) : 7.42 (driven) to obtain maximum speed of 25km/hr. The calculations were based on the following equations. The exact maximum speed is both a function of the motor purchased for one-wheeled motorcycle as well as the pulley sizes available. System was constrained by an upper limit of 25km/hr due to concerns about torque, and legal limits on licensing for motorized bicycles and scooters. The lower limit of 20km/hr was not significantly influenced by outside variables except our desire to enhance the bike's performance.

Speed motor=1500 rpm

Speed desired=201rpm (25km/hr)

Speed motor/Speed desired=1500/201=7.412

Gear reduction

primary stage= $N_1:N_2=1500/701=2.13$

secondary stage= $N_3:N_4=701/201=3.48$

## 3. Two-stage transmission system:

Design of transmission system plays very important role in effective working of one-wheeled motorcycle. Transmission system consists of belts, pulleys, and intermediate shaft to transmit power from motors to wheel. Based on available torque and desired maximum speed at wheel, transmission system is designed with reduction stage. Single stage reduction transmission system is more preferable option but considering limitation of space as it could not be employed due to large pulley size required to obtain desired reduction of speed at wheel. Hence, two stage reduction transmission system is designed and implemented which minimizes the component size in system. Splitting the transmission system in two stages increases the complexity but decreases the size of components which is more critical factor than minimizing

the components. Design of two stage transmission system consists of primary stage and secondary stage.

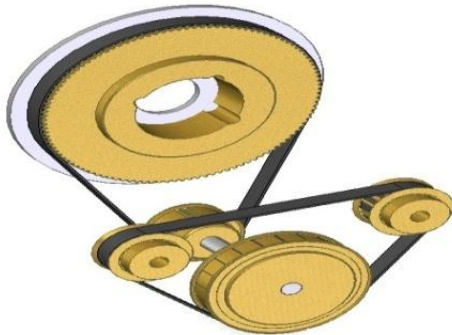

**Fig -1:** Two-stage Transmission System

### 3.1 Primary stage:

Primary stage (fig 2) is designed to transmit power from motors to intermediate shaft(Jackshaft). For designing primary stage, certain design consideration had taken into account as centre to centre distance available such that motors does not conflict with each other or with wheel rim, gear reduction ratio to obtain required speed from motor to intermediate shaft and transmission drive which transmit the power with maximum efficiency and less maintenance. Taking into consideration of a number of electric bike hobbyist, timing belt drive are most preferable drive for transmitting the power than chain drive when motor rpm exceeds 1000rpm. Timing belts are less noisy and efficient than chain drive making it suitable for power transmission. Designing transmission system in electric drive for one-wheeled motorcycle to obtain desire speed of 20-25 Km/hr is carried after acquiring required data:

Centre to centre distance from motor to Jackshaft=104.24mm and belt length required=565mm

Design HP=(1.07) x (1.2)=1.28Kw (where 1.2 is service factor from Gates design manual)

1st stage reduction ratio=2.13

From the data, selection for standard best suited belt and pulley for designing transmission system for primary stage are obtained from POWERGRIP® GT®3 drive design manual.

Belt=565-5MGT.P.L.22.0244-113

Belt width=15mm

No. of teeth's on driving pulley=30 No. of teeth's on driven pulley=64

From the obtained data diameter of pulleys are found from Gates-sprocket specifications manual(aluminium).

Driving pulley=1.88 inch pitch diameter

Driven pulley=4.010 inch pitch diameter.

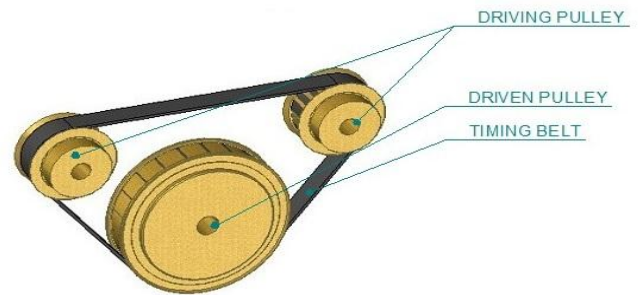

**Fig -2:** Primary Stage

### 3.2 Secondary stage:

This stage is relatively simpler to design and it transmits power from intermediate shaft to the wheel. Intermediate shaft (fig 3) is simple shaft which connect two transmission stages and is supported with bearings at both ends near pulleys. Jackshaft is designed with mild steel- EN8 for 142mm length with thickness of 20mm. Component selection for secondary stage is by considering gear reduction ratio to obtain desired speed at wheel and centre to centre distance between wheel rim and intermediate shaft.

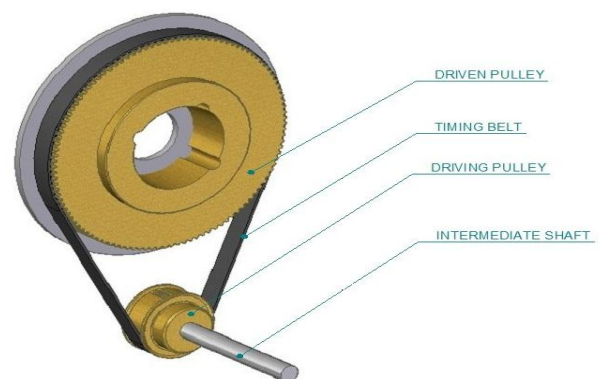

**Fig -3:** Secondary Stage

Calculations for determining required belt and pulley to design secondary stage to transmit power from intermediate shaft to wheel rim are done by obtaining required data as,

Centre to centre distance=158mm

Reduction ratio=3.5

So from POWERGRIP® GT®3 drive design manual obtains best suited belt and pulleys for effective transmission.

Belt =700-5MGT.P.L.27.559-140

Belt width=15mm

Teeth on driving pulley=32

Teeth on driven pulley=112

So from Gates-sprocket specification manual obtain pulley diameters.

Driving pulley=2.005 inch pitch diameter.

Driven pulley=7.018 inch pitch diameter.

Designing two stage transmission system with the selection of components from the available standard gives efficient and desired results.

### 3.3 Intermediate stage (Jackshaft):

The Jackshaft represents the intermediate stage of the transmission system. It is simply a shaft which connects two stages of a power transmission (High speed-low torque & low speed – high torque). The shaft needs to be supported by bearings at each end of the drive. Therefore, one bearing would be near primary stage driven pulley and other is near secondary stage driving pulley. Due to the location of Jackshaft we determined that two bearings would be sufficient. The steel shaft is secured by 4 tap screws, two from each bearing. Comparing different materials, composite materials and titanium are better than medium carbon steel but as total load is not much and selecting the material which will be easily available and cost effective so selection of EN8 material for design of jackshaft is done.



Fig -4: Intermediate shaft (Jackshaft)

### 4. Designed Transmission system for one-wheeled motorcycle

following images shows actual transmission system designed and implemented inside one-wheeled motorcycle

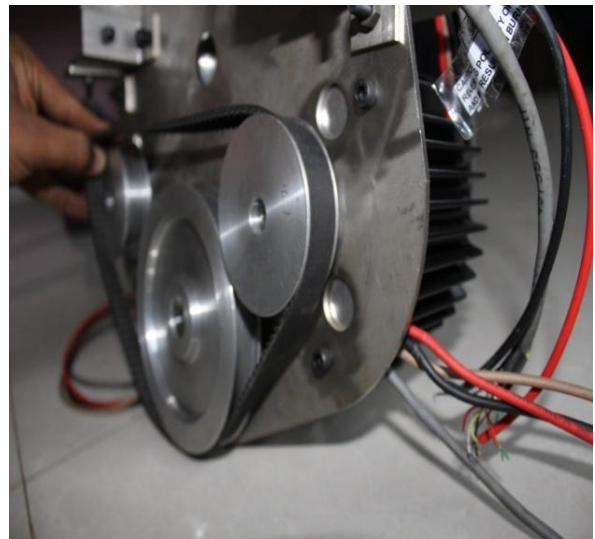
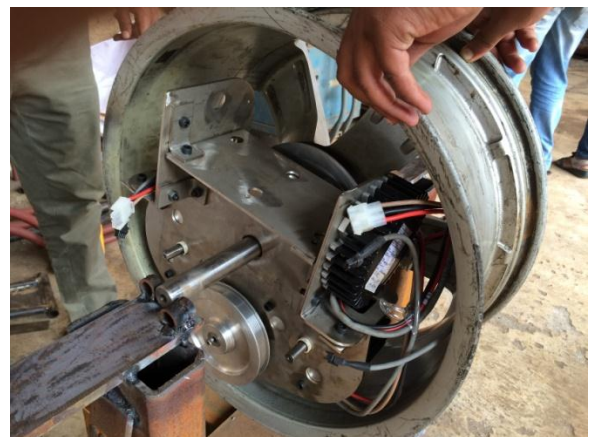

Fig -5: Primary stage and Secondary stage transmission system







**Fig -6:** Implementation of designed transmission system in side wheel of motorcycle

### 3. CONCLUSIONS

This paper concludes design of a two-stage transmission system which can be easily fitted with in the available space of one-wheeled bike. The design of transmission system is done in such a way that it performs efficiently giving desired output required with less noise and vibration, and does not require regular maintenance. Design of transmission system i.e. component selection is done in such a way that it reduces the overall weight of system.

### REFERENCES

- [1] Rassem R. Henry, Bruno Lequesne and Shaotang Chen "Belt-Driven Starter-Generator for Future 42-Volt Systems" SAE 2001 World Congress Detroit, Michigan March 5-8, 2001 .
- [2] Gurusurthy Veerapathiran<sup>1</sup>, Prabu Dhanapal<sup>1</sup>, Ranjithkumar Koumaravel<sup>2</sup>, Padmanaban Narayanamoorthy<sup>2</sup>, Vignesh Ravi<sup>2</sup>, Chandran<sup>2</sup> "Power Transmission Through Timing Belt In Two Wheeler Motors "Int. Journal of Engineering Research and Applications ISSN : 2248-9622, Vol. 5, Issue 3, ( Part -5) March 2015, pp.20-25.
- [3] Ravikant, Gopal Krishan, Mukesh Didwania "Modal analysis of drive shaft using FEA" Department of MAE, Amity University Haryana International Journal of Engineering and Management Research, Vol.-3, Issue-1, February 2013 ISSN No.: 2250-0758.
- [4] Sandeep Gujran<sup>1</sup> and Shivaji Gholap<sup>2</sup> "Fatigue Analysis of Drive Shaft" INTERNATIONAL JOURNAL OF RESEARCH IN AERONAUTICAL AND MECHANICAL ENGINEERING vol.2 issue. 10, october 2014.
- [5] Stuart H. loewenthal "Design of power transmitting shafts" NASA reference Publication 1123 July 1984.
- [6] Muhsin Abdur-Rahman, Bo Hu" Design and Implementation of a Hybrid Electric Bike" Engineering 90 Senior Design Project Date: May 05, 2005.
- [7] P. Jayanaidu<sup>1</sup>, M. Hibbatullah<sup>1</sup>, Prof. P. Baskar<sup>2</sup> "Analysis of a Drive Shaft for Automobile Applications" IOSR Journal of Mechanical and Civil Engineering (IOSR-JMCE) e-ISSN: 2278-1684, p-ISSN: 2320-334X, Volume 10, Issue 2 (Nov. - Dec. 2013), PP 43-46.
- [8] R. A. Gujar<sup>1</sup>, S. V. Bhaskar<sup>2</sup> "Shaft Design under Fatigue Loading By Using Modified Goodman Method" Department of Mechanical Engineering, Pune University, Maharashtra. International Journal of Engineering Research and Applications (IJERA) ISSN: 2248-9622 Vol. 3, Issue 4, Jul-Aug 2013, pp.1061-1066.
- [9] G. Domek "Meshing in Gear with Timing Belts" IACSIT International Journal of Engineering and Technology, Vol.3, No.1, February 2011 ISSN: 1793-8236
- [10] Catalogues: Gates power grip GT design.