

# Design and Development of Bullock Cart in Pesticides Sprayers Pump

Mr. Manoj Kharche<sup>1</sup>, Prof. Anurag A. Nema<sup>2</sup>, Prof. Anantharma<sup>3</sup>

<sup>1</sup>P.G. Student, M. E. Mechanical Engineering, Dhole Patil College of Engg. Pune, Maharashtra India

<sup>2,3</sup>Asst. Prof. M. E. Mechanical Engineering, Dhole Patil College of Engg. Pune, Maharashtra, India

**Abstract**— The principle motive of this assignment is to research and development of insecticides sprayer pump. This task often centered on pesticide sprayer's pump with precise layout characteristics consisting of ergonomics, smooth to fabricate, with aesthetic fee with lowest fee. First of all this work is carried out by using the usage of pesticide sprayers, hand pump that is completely operated by hand. But this sprayer has positive barriers like it cannot maintain required pressure, it leads to issues of returned ache. However, this equipment additionally leads to overlook an application of chemical substances and ineffective manipulate of target pest which ends up in lack of pesticides due to dribbling or drip all through utility. A pesticide sprayer must be accessible and with a multiplied tank ability and also price is reduced, labor and spraying time. With a purpose to reduce these troubles, wide variety of sprayer introduce within the marketplace, but those devices do now not meet the above troubles. The conventional sprayer having problems such because it needs plenty of effort to push the lever up and down so one can create the pressure to spray. One extra issue of petrol sprayer is to want to buy the gas, which increases the going for walks value of the sprayer. So to conquer all the drawbacks we must design pesticide sprayer pump that's completely operated through a chain force which is pushed by way of bullock cart. There may be an enormous amount of growth in performance, lessen in manpower, labor cost and decrease walking fee. So multi-functional we growth the performance, lessen the time taken and finished all the desired parameters we required from pesticide sprayers hand pump.

**Keywords:** chain drives design, reduce in manpower, performance.

## I. INTRODUCTION

In India approximately seventy three% of population is immediately or not directly relies upon the Agriculture. Hence it is said that India is an agricultural based country. But till now our farmers are doing farming in identical traditional methods. They are doing seed sowing, fertilizers and insecticides spraying, cultivating by means of conventional techniques. There is want of development on this zone and maximum usually on fertilizers insecticides spraying technique, as it requires greater efforts and time to spray via traditional way.

Most of Asian international locations are at growing stage and they are going through the hassle of high population and compared to that agricultural productivity is a good deal lower compared to advanced countries. India is one of the international locations who are facing the equal hassle. This is caused due to low stage farms, insufficient energy availability to farms and poor level of farm mechanization.

In order to meet the requirement of food of growing populace and speedy industrialization, there is a need of the modernization of agriculture area. On many farms production suffers because, postpone in sowing, wrong distribution suffer due to the fact put off in sowing, mistaken distribution of insecticides and fertilizers, harvesting. Mechanization solves all the problems that are answerable for low production. It Conserves the input and precision in work and gets better and identical distribution. It reduces quantity wanted for higher Reaction, prevent the losses and wastage of enter carried out. It gets excessive productiveness so that value of manufacturing will reduced.

To attain the requirement of manufacturing Agriculture implement and equipment program of the authorities take steps to increase availability of implement, pumps, tractors, power tillers, harvester and other power operated machines. Unique emphasis was laid at the later as extra than 65% of the farmers fall in small and marginal category.

Commonly mechanization of small forms is very tough and non-less costly however Japanese make it takes place. They're through proper mechanization they did farming and get more manufacturing than Indian. They're using the current time saving system of required sizes to get extra production. Jap led agriculture to new heights.

Spraying, cultivating via conventional methods. There's need of improvement on this quarter and maximum typically on fertilizers insecticides spraying method, as it calls for extra efforts and time to spray by using conventional way.

## 1.1 Varieties of sprayers

### Portable sprayers

These are small hand-held or backpack sprayers can manage small jobs, like spraying weeds in a driveway. They could be used sometimes in residential and rural houses. Common chemicals applied could be round-up. Some of transportable sprayer noted is given underneath:

- a) Hose sprayers
  - b) Tank sprayers
  - c) Trombone sprayers
  - d) Hand pump sprayers
  - E) Backpack (Knapsack) Sprayer
- All terrain automobiles (ATV) sprayers
- a) Two at the back of sprayers:
  - b) Skid sprayer

### Sorts of spray weapons

- a) Spot sprayer gun
- b) Broadcast/growth spray
- c) Tree sprayer gun
- d) Lawn sprayer gun

## 1.2 Objectives

1. Firstly we tried to design pesticides sprayers which operated through chain drive which is driven by bullock cart whose running cost is zero.
2. Overall we increase in pesticides spraying area.
3. Reduce labour cost.
4. Reduce time taken.
5. Reduce running cost.
6. Reduce pollution etc.
7. Reduce the manufacturing cost.
8. Easy to handle.

## II. LITERATURE REVIEW

Sandeep H. Poratkar, Dhanraj R. Raut, 'Development of Multinozzle Pesticides Sprayer Pump'-

India is a land of agriculture which accommodates of small, marginal, medium and rich farmers. Small scale farmers are very inquisitive about manually lever operated knapsack sprayer because of its versatility, fee and design. But this sprayer has sure boundaries adore it cannot keep required strain; it cause problem of returned pain. But this device can also lead to misapplication of chemicals and useless control of goal pest which leads to lack of insecticides due to dribbling or waft for the duration of application. This phenomenon no longer simplest provides to cost of production but additionally cause environmental pollution and imbalance in herbal echo system. This paper indicates a model of operated by hand multi nozzle pesticides sprayer pump with a view to carry out spraying at most prices in minimum time. Consistent drift valves can be implemented at nozzle to have uniform nozzle strain.

Shivaraja Kumar. , Parameswaramurthy. Development of Wheel Driven Sprayer

Used to kill insects or otherwise manipulate their duplicate. Those herbicides, pesticides, and fertilizers are implemented to agricultural crops with the help of a unique tool referred to as a "Sprayer," sprayer offers ultimate performance with minimum efforts. By the invention of sprayers, this permits farmers to reap the maximum agricultural output.

A pesticide sprayer must be portable and with an improved tank potential as well as should bring about price reduction, labor and spraying time. So one can lessen these problems, there are a number of sprayer added in the marketplace, but these gadgets do not meet the above issues or demands of the farmers. The conventional sprayer having the problems such because it needs lot of attempt to push the liver up and down in an effort to create the stress to spray. Another issue of petrol sprayer is to need to purchase the gas, which will increase the strolling cost of the sprayer

Shivarajakumar. Parameswaramurthy. 'design and improvement of Wheel and Pedal Operated Sprayer'-

Chemicals are widely used for controlling disease, insects and weeds inside the vegetation. They're capable of store a crop from pest assault handiest whilst implemented in time. The chemical substances are steeply-priced. Therefore, gadget for uniform and effective software is critical. Dusters and sprayers are usually used for making use of chemical compounds. Dusting, the simpler method of making use of chemical, is satisfactory proper to portable equipment and it generally requires easy gadget. However it is much less green than spraying, due to the low retention of the dirt. I have proposed device this is wheel and pedal operated sprayer, it is a portable device and no want of and additionally peddling the system. In this equipment the usage of reciprocating pumps and there is an accumulator supplied for the continuous flows of liquid to create essential pressure for the spraying motion. This wheel operated pesticide spray system consumes less time and avoids the pesticide from coming from the front of the nozzles which will in contact of the person that sprays insecticides.

### III. PROJECT OVERVIEW

Basic intent of this project is to pesticides spryer system. Since due to the low running cost high area of pesticides is covered and efficiency increase General parts in pesticides include chain drive, wheel, nozzle, flexible pipe, double acting spray pump. A schematic of chain drive and bullock cart is presented below.

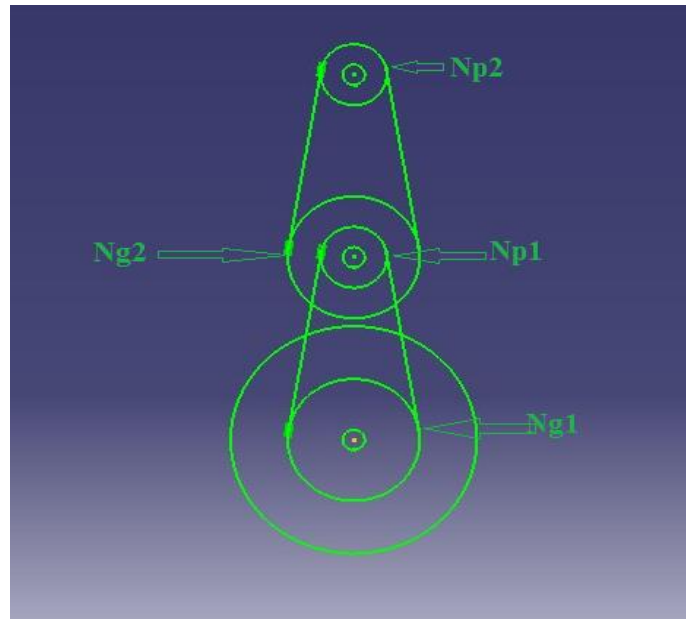

Figure1: Schematic diagram of chain drive.

#### Calculation

Wheel diameter = 560mm.  
=0.56 m.

Velocity = 5-6 km/hr

$$V = 6 \times \frac{5}{18}$$

$$V = 1.667 \text{ m/s}$$

$$V = \frac{\pi dN}{60}$$

$$1.667 = \frac{\pi \times 0.56 \times N_{G1}}{60}$$

$$N_{G1} = 56.85 \text{ rpm.} \approx 57 \text{ rpm.}$$

Gear ratio is  $G_1 = 3.5$

$$G_1 = \frac{N_{p1}}{N_{G1}}$$

$$N_{p1} = 199.2 \approx 200 \text{ rpm.}$$

$$N_{p1} = N_{G2}$$

Gear ratio is  $G_2 = 3.5$

$$G_2 = \frac{N_{p2}}{N_{G2}}$$

$$N_{p2} = 700 \text{ rpm.}$$

Total Weight = 450 kg = 4415 N

$$\begin{aligned} \text{Rolling Resistance} &= \text{Total Weight} \times \text{RRC (rolling resistance coefficient)} \\ &= 4415 \times 0.03 \\ &= 132.5 \text{ N} \end{aligned}$$

$$\text{Accelerating force} = \frac{W \times V}{g \times t_a}$$

$$= \frac{4415 \frac{N_{p1} N_{p1}}{N_{G1} N_{G1}} 1.669}{9.81 \times 10}$$

$$= 75.023 \text{ N}$$

Total Force = Accelerating Force  $\times$  rolling resistance

$$= 75.023 \times 132.5$$

$$= 207.5 \text{ N}$$

$$\begin{aligned} \therefore \text{Torque} &= F \times \frac{d}{2} \\ &= 58.1 \text{ Nm.} \end{aligned}$$

$$\text{Power} = \frac{2 \times \pi \times N \times T}{60}$$

$$P = \frac{2 \times \pi \times 700 \times 58.1}{60}$$

$$P = 4258.95 \text{ Watt}$$

$$P = 5.71 \text{ HP}$$

#### IV. MODEL AND ANALYSIS OF BULLOCK CART

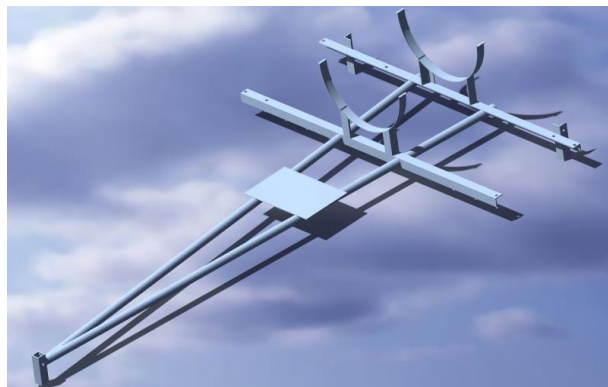

**Figure 2:** Actual model of the bullock card frame.

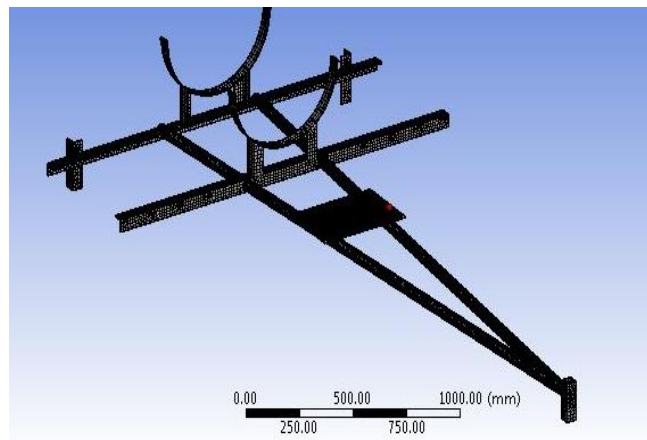

Figure 3: Meshed Component.

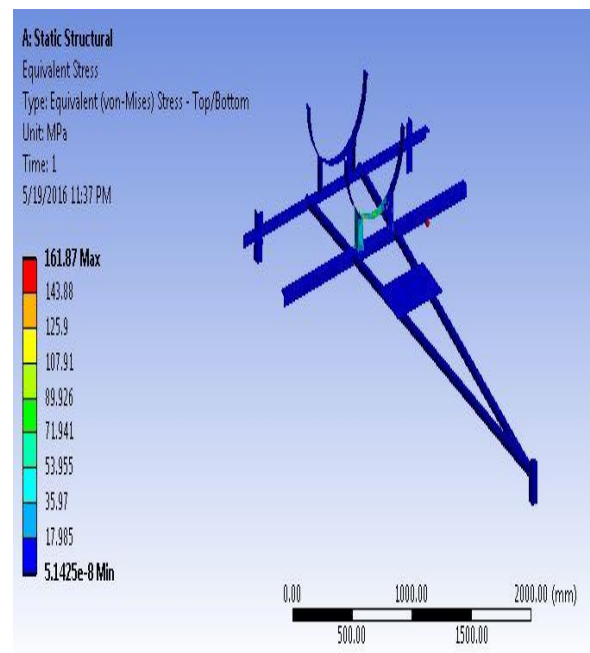

Figure 4: Equivalent stress.

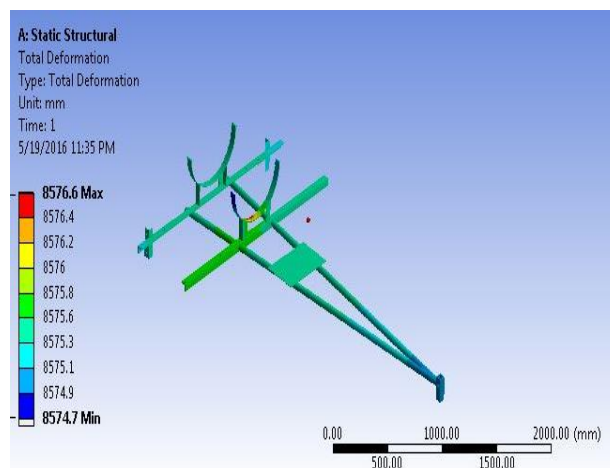

Figure 4: Total Deformation.

## V. RESULT AND DISCUSSION

Data Collection for the Sprayer Calculation

**Table 1:-**Data collection for the sprayer calculation

Time consumed	60 seconds
Replicate	Volume of water collection (lit)
1	1.9
2	2.0
3	1.8
4	1.85
5	1.95

Average volume flow out from the implement

$$= \frac{1.9 + 2.0 + 1.8 + 1.85 + 1.95}{5}$$

$$= 1.90 \text{ lit.}$$

Amount of water flow out from the implement per second

$$= \frac{1.9}{60}$$

$$= 0.032 \text{ lit/s}$$

Application rate

$$F = \frac{SDA}{10000}$$

Where F= Flow rate lit/min

S= swath width in meter

D=Operator walking speed in M/min

A=Application rate in lit/hr.

$$F = \frac{SDA}{10000}$$

$$F = \frac{10000}{2 \times 60 \times A}$$

$$5 = \frac{10000}{120 \times A}$$

$$A = 415 \text{ lit/hr.}$$

## VI. CONCLUSION

This chain drive sprayer is specially low price and clean to transport in the fields and also improves the nice of spraying pesticides. The advised model has eliminated the problem of returned pain, on account that there is no need to hold the tank (pesticides tank) at the lower back. As recommended version has more range of nozzles which will cowl a maximum area of spraying in minimum time.

## REFERENCES

1. Sandeep H. Poratkar, Dhanraj R. Raut, 'Development of Multinozzle Pesticides Sprayer Pump' (march-april. 2013)
2. VinayakKhawas ,NitishDas,NamitMaske, ' Agricultural Fertilizers and Pesticides Sprayers - A Review'(April 2015)
3. Shivarajakumar. Parameswaramurthy. 'Design And Development of Wheel And Pedal Operated Sprayer'(June 2014)
4. Swapnil L. Kolhe, Nilesh B. Gajbhiye, Vivek B. Deshmukh "Eco-Friendly Mechanically Operated Multipurpose Spray Pump"(April 1994)
5. MehrdadFouj Lali1, ParvizAhmadiMoghadam. "Designing, construction and evaluation of tractor-back sprayer with Variable Rate Technology (VRT) by using aerial maps information"(June 1992)
6. Shivaraja Kumar., Parameswaramurthy. 'Development Of Wheel Driven Sprayer' (2014)

## Author Profile



**Mr. Manoj A. Kharche** received the bachelor of Engineering from SVPM'S collage of Engg. Malegaon (Bk), Pune, in 2014. He is now pursuing M.E. in Design Engineering from Dhole Patil College of Engg. Pune.



**Prof. Anurag.A.Nema** is allied with Dhole Patil College of Engineering Pune, department of mechanical engineering as Assistant Professor. He had completed his M. Tech (CAD CAM) from Rashtrasant Tukadoji Maharaj Nagpur University in 2009. The author is associated with teaching from 10 years. His area of Interest is Computer Aided Engineering, fixture design, NVH, Vibration Measurement.



**Prof. Anantharma** With the qualification ME (Machine Design) from Bangalore University, He have been working as an Assistant Professor in Dhole Patil College of Engineering since 4 years with a total of 24 years of teaching experience in various technological institutes in Karnataka and Maharashtra. He published technical papers in 2 national and 2 international journals and presented in conferences.