

Secured ZigBee Based Weather Monitoring for Agriculture

Mr. Samir P. Mendhe , Prof. Sonal Honale

Asst. Teacher, New Sulbha Coaching Classes, Maharashtra, Nagpur

Professor, Dept of M.Tech, Abha Gaikwad Patil College, Maharashtra, Nagpur

Abstract - To analyze large amount of agriculture data computing environment to provide optimal solutions for effective farming. A decision tree, is a diagram that a decision maker can create to help select the best of several alternative courses of action. The primary advantage of a decision tree is that it assigns exact values to the outcomes of different actions, thus minimizing the ambiguity of complicated decisions. Because they map out an applied, real-world logical process, decision trees are particularly important to build "smart" computer applications like expert systems. They are also used to help illustrate and assign monetary values to alternative courses of action that management may take. In this research, the use of a decision tree will process input parameter to alarm when an inputted parameter matches predefined conditions.

Key Words: Smart Computer, Decision Tree.

1.INTRODUCTION

A **weather station** is a facility with instruments and equipment to make observations of atmospheric conditions in order to provide information to make weather forecasts and to study the weather and climate. The measurements taken include barometric pressure, humidity, wind speed, wind direction, and precipitation amounts. Wind measurements are taken as free of other obstructions as possible, while humidity measurements are kept free from direct solar radiation, or insulation. Manual observations are taken at least once daily, while automated observations are taken at least once an hour. Investigation of ZigBee Wireless Sensors was to demonstrate the functionality and versatility of ZigBee (low power wireless networks) technology by way of implementing a fully functional. Wireless Weather Station within the EEE building for remote data logging application using two low power, ZigBee sensor nodes.

ZigBee is targeted at applications that require a low data rate, long battery life, and secure networking. ZigBee has a defined rate of 250 kbit/s, best suited for periodic or intermittent data or a single signal transmission from a sensor or input device. Applications include wireless light switches, electrical meters with in-home-displays, traffic management systems, and other consumer and industrial

equipment that requires short-range wireless transfer of data at relatively low rates. The technology defined by the ZigBee specification is intended to be simpler and less expensive than other WPANs, such as Bluetooth.

2.HARDWARE REQUIREMENT / SOFTWARE REQUIREMENT

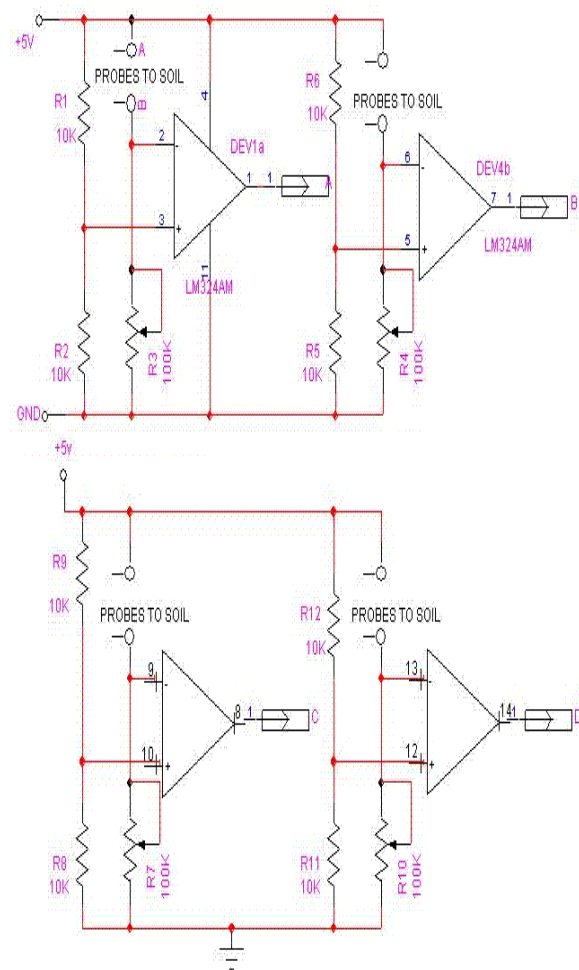

Fig 1. Component description Humidity

2.1 IR Transmitter

IC 555 is used as an Multivibrator. This is a free running oscillator and the frequency can be adjusted using 100k preset (variable resistor). Free running oscillator means, it is itself starting circuit which outputs a waveform that repeats itself without being either triggered or re-triggered. The output of the oscillator is periodic (i.e. repeats itself regularly) pulse or wave train. In a periodic signal the wave repeats itself indefinitely until the circuit is either turned off or otherwise inhibited.

In this mode of operation, the capacitor charges and discharges between $1/3 V_{cc}$ and $2/3 V_{cc}$. As in the triggered mode, the charge and discharge times and therefore the frequency are independent of the supply voltage.

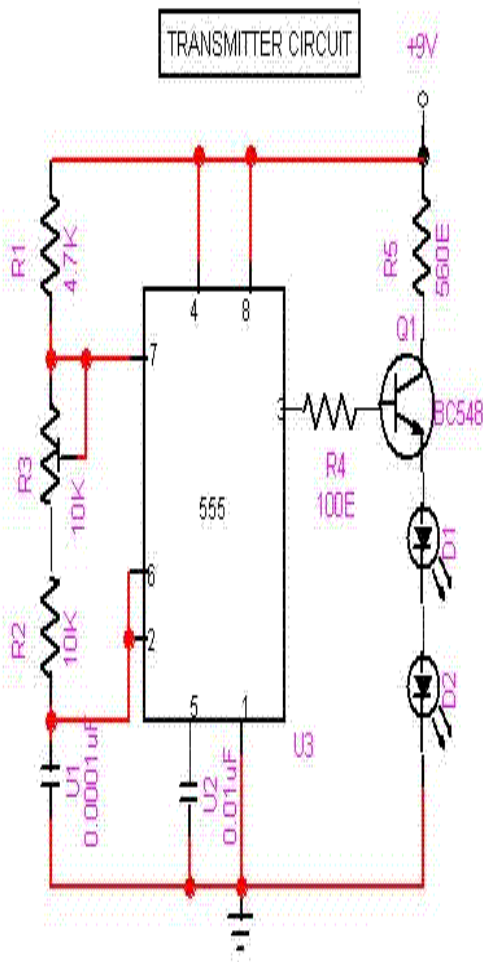

Fig 2. Transmitter Circuit

In this circuit value of capacitor $C = 0.1\mu\text{f}$ is constant because we cannot vary the value of capacitor whereas 100k is a variable resistor with the help of this frequency is adjusted between 38 kHz for obtaining the stable square wave and it is transmitted through infrared LED.

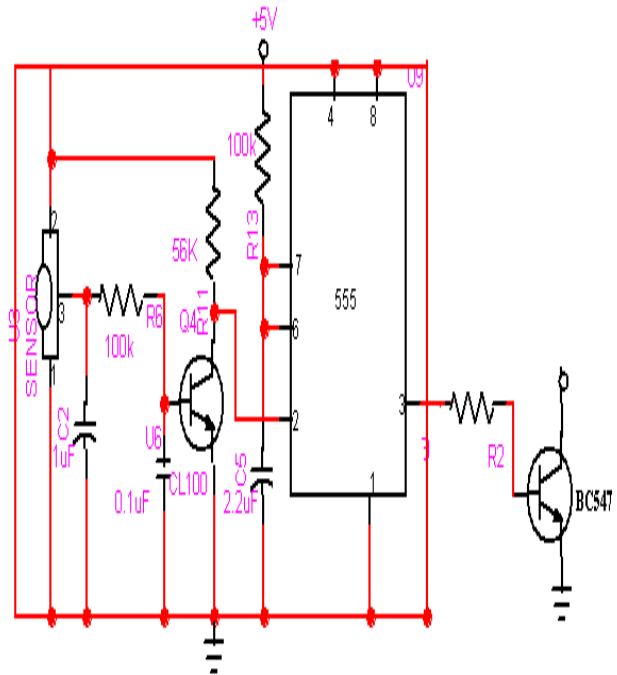

Fig 3. IR Receiver Circuit

When IR signals does not falls on the TSOP 1738 its output pin no.3 goes high. R14 resistance is used to limit the current at the output of the TSOP and fed to pin1 of the NOT gate ic which has internal 6 not gate. 1st not gate invert its output and its output is again inverted by another not gate and increases its output current to switch the switching transistor 2N2222A or SL100 which is NPN switching transistor. The ground signal is generated by the transistor is fed to the PC parallel port to process data.

Receiver circuit operated at 5V DC and it is drive from power supply circuit. Transformer converts 230V AC to 12V AC and the 12V AC is converted into DC by Diode D1 & D2 it filtered by Capacitor C1, IC3 gives. Regulated 5V DC to other circuit. Infra-red receiver module detected 38 kHz signal this is transmitted from transmitter circuit. When transmitter is on I/R sensor does not generate signal and its output go to high level. This output level is fed to Computer Circuit.

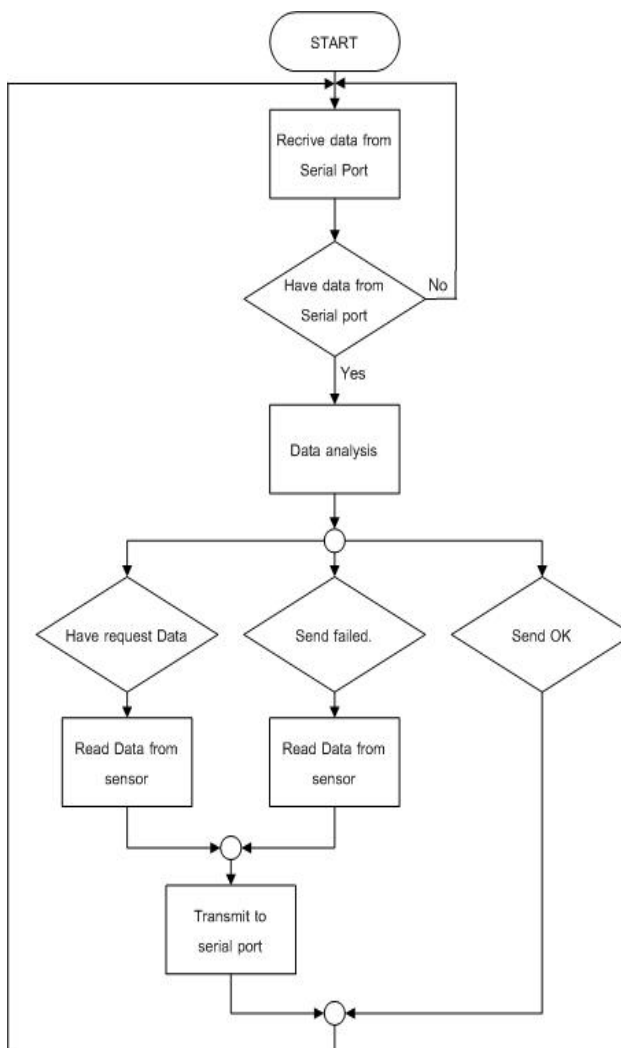

Fig 4. Flowchart Sensor node process

4. REFERENCES

- 1]Yu Haibin, Zeng Pengliang, "Intelligent wireless sensor network system ,"Beijing: Science Press, 2006.289.
- 2] Xu Z,Zheng H D,Liu Y D, "Research on mine monitoring system based on CAN," Journal of China University of Mining and Technology ,2004, 33(4) : 421-423.
- 3]TIAN Ze, "ARM7 embedded experimental development and practice, "Beijing: Beihang University Press, 2006,pp.125167
- 4]Microchip ZigBee specification Version 1.0,US: Microchip Technology Inc, 2005.433
- 5] Reza Mohamaddoust , Abolfazl Toroghi Haghightat, Mohamad Javad Motahari Sharif and Niccolo Capanni, "A Novel Design of an Automatic Lighting Control System for a Wireless Sensor Network with Increased Sensor Lifetime and Reduced Sensor Numbers", Sensors (2011) ,Volume No.-11(9), pp. 8933-8952.
- 6] De Dominicis, C.M.; Flammini, A.; Sisinni, E.; Fasanotti, L.; Floreani, F.; "On the development of a wireless self localizing streetlight monitoring system ", Sensors Applications Symposium IEEE, pp. 233 - 238 ,2011.
- 7] Shentu, Xudan; Li, Wenjun; Sun, Lingling; Gong, Siliang, "A new streetlight monitoring system based on wireless sensor networks", International Conference on Information Science and Engineering, pp. 6394 – 6397, 2010.
- 8] Chun-ling Fan and Yuan Guo, "The Application of a ZigBee Based Wireless Sensor Network in the LED Street Lamp Control System", International Conference on image Analysis and Signal Processing (IASP), 2011, pp. 501 – 504.

3. CONCLUSIONS

- Weather Reporting System.
- Industrial Applications.
- ZigBee protocols are intended for use in embedded applications requiring low data rates and low power consumption. Typical application areas include1.Home entertainment and control2.Home awareness3.Mobile Services4.Commercial building.
- The technology is intended to be simpler and cheaper than other WPANs such as Bluetooth.