

SMART PLANNING IN SOLID WASTE MANAGEMENT FOR A SUSTAINABLE SMART CITY

Ms.A.Sivasankari¹, Mrs.V.Priyavadana²

¹ Head of the Department, Department of Computer Science, D.K.M College for Women, Tamil Nadu, India

² Research Scholar, Department of Computer Science, D.K.M College for Women, Tamil Nadu, India

Abstract - Solid waste management is one of the most important challenges throughout the world and it has become a critical issue in developing countries where a rapid increase in population has been observed. Waste collection is a complex process that requires the use of large amount of money and an elaborate management of logistics. Every city can become smarter. Smart cities start with smart systems that work for the benefit of both residents and the environment. The cities that succeed in making the transition to 'smart' will be those that improve their critical systems by combining a bottom-up, systems-centric approach with a top-down, data-centric one. It is the improvement and integration of various critical city systems — done in a step-by-step manner — that become the cornerstones to making a smart city a reality. To attract the most promising residents, companies, and organizations, as well as promote a thriving culture, cities must achieve three critical traits: become more efficient, more livable, and more sustainable. By the end of the current decade, many technologies critical to a smart city, including monitoring and sensor technologies, intelligent traffic systems, and energy management systems for buildings, will be deployed on every continent. While the challenges are many, the benefits are significant. Going beyond the obvious environmental benefits, the improvement of systems can contribute to social equality through universal access to a city's public services. They save lives by allowing for more immediate access to emergency services. They make cities more resilient in times of crisis, allow cities to prepare for hazards, and help to restore city services from disruption in the wake of one. They create new economic zones that drive growth and prosperity. In this paper an approach to smart waste collection is proposed able to improve and optimize the handling of solid waste.

Key Words: Smart city, solid waste management, Sensor technologies, intelligent traffic systems, universal access.

1.INTRODUCTION

The world is in a stage of up gradation, there is one stinking problem we have to deal with Garbage. In our daily life, we see the pictures of garbage bins being overfull and all the garbage spills out. This leads to the number of diseases as large number of insects and mosquitoes breed on it. A big challenge in the urban

cities is solid waste management not only in India but for most of the countries in the world. Hence, such a system has to be build which can eradicate this problem or at least reduce it to the minimum level. The project gives us one of the most efficient ways to keep our environment clean and green. The smart city concept is still new in India, although it has received a lot of attention in few years when our present prime minister gave the idea of building 100 smart cities throughout India. Now, with the upcoming large number of smart cities, large numbers of responsibilities are also required to be fulfilled.

1.1 Definition Of Smart City

The conceptualization of Smart City, therefore, varies from city to city and country to country, depending on the level of development, willingness to change and reform, resources and aspirations of the city residents. A smart city would have a different connotation in India than, say, Europe. Even in India, there is no one way of defining a smart city. Some definitional boundaries are required to guide cities in the Mission. In the imagination of any city dweller in India, the picture of a smart city contains a wish list of infrastructure and services that describes his or her level of aspiration. To provide for the aspirations and needs of the citizens, urban planners ideally aim at developing the entire urban eco-system, which is represented by the four pillars of comprehensive development-institutional, physical, social and economic infrastructure. This can be a long term goal and cities can work towards developing such comprehensive infrastructure incrementally, adding on layers of 'smartness'.

2. HARDWARE COMPONENTS

Each garbage can is given a number id which is stored in database with its location. A camera is placed at each garbage can .the camera used is INTEX IE305WC which is a 16 megapixel camera used for

capturing images of garbage can continuously. A database is created in PC of different set levels which is used to compare with the images that are taken previously by camera. This is done with image processing. This is interfaced with microcontroller with help of RS232 cable. Simultaneously weighing sensor (load cell CZL601) is used. This is a single point load cell of total precision C3 class made up of material i.e. Aluminum alloy. It senses the weight of garbage can. It is interfaced with microcontroller through ADC.

2.1 Web Camera

It is placed above the Garbage Can to capture images of the level of garbage in it. A webcam is a video camera that feeds or streams its image in real time to or through a computer to computer network. When "captured" by a computer, the video stream may be viewed, saved or sent on to other networks through the email by using internet. When this data is sent to a remote location, the video stream may be viewed, saved or on sent there, which is unlike an IP camera(which connects using Ethernet or (Wi-Fi) a webcam is generally connected by using a USB cable, or by similar kind of cables

2.2 Load Sensor

The LOAD cell will continuously give the weight readings in voltage format, which is then given to a signal conditioning unit which amplifies the voltage and is then give to the μC . The μC then converts the analog signal to digital format.

A load cell is a transducer that is used to sense and convert a force into an electrical signal. The output of the transducer can be scaled to calculate the force applied to the transducer. The various types of load cells are available, like include Hydraulic load cells sensor, Pneumatic load cells sensor and Strain gauge load cells sensor.

2.3 Microcontroller

It is used to process information that is been given by the sensors. It compares the received data with the threshold level set and accordingly output is generated.

The LPC2131/32/34/36/38 microcontrollers are based on a 16/32-bit ARM7TDMI-S CPU with real-time emulation and embedded trace support, that combine the microcontroller with 32 kB, 64 kB, 128 kB, 256 kB and 512 kB of embedded high-speed flash memory. A128-bit wide memory interface and unique accelerator architecture enable 32-bit code execution at maximum clock rate.

i) LCD (Liquid Crystal Display)

LCD is used in a project to visualize the output of the application. We have used 16x2 LCD. So we can write 16 characters in each line. Total 32 characters we can display on 16x2 LCD. LCD can also use in a project to check the output of different modules interfaced with the microcontroller. Thus LCD plays a vital role in a project to see the output and to debug the system module wise in case of system failure in order to rectify the problem.

ii) GSM Module

It is used to send message to the garbage depot if the Garbage Can exceeds the set threshold level. With the help of GSM module interfaced, we can send short text messages to the required authorities. GSM module is provided by sim uses the mobile service provider and send sms to the respective authorities as per programmed. It operates at either the 900 MHz or 1800 MHz frequency band.

iii) Robot Mechanism

This robot mechanism is nothing but a machine capable of physical motion. In this project we use dc motor which is fixed on plate on which Garbage Can is mounted. This plate is used for tilting the Garbage Can by which garbage is transferred into garbage collecting vehicle.

iv) DC Motor

DC Motors are used to physically drive the application as per the requirement provided in software. To drive a dc motor, we need a dc motor driver called L293D. This dc motor driver is capable of driving 2 dc motors at a time.

The microcontroller compares the set limit with input data. If anyone or both input data crosses threshold level. Then microcontroller which is interfaced with GSM module sends a message to the server. The sent messages contain the slave id of the garbage can. The server compares the slave id with its database which contains record of slave id and location of each garbage can located in city. Then it gives exact location of the garbage can which is full or over weighted to the driver of waste disposal vehicle.

After receiving the message by the server the waste disposal vehicle reaches to the desired location. Then the driver enters set password with help of keypad in microcontroller. When the set password matches robot mechanism is activated. This robot mechanism is nothing but a machine capable of physical motion, in this project we use

dc motor which is fixed on plate on which garbage can is mounted .This plate is used for tilting the garbage can by which garbage is transferred into garbage collecting vehicle.

Table -1: Hardware Components and specifications

Components	Specifications
Microcontroller	PIC-16F73
Ultrasonic Sensor	HC-SR04
GSM Module	SIM-900A, IMEI-865904022247974
Motor	60 rpm DC Motor
LCD	16X2 (JHD162A)
Motor Driving IC	L293D
Voltage Regulator	7805
Register	10kohm
Capacitor	100uf and 22pf (2)
Oscillator	Crystal Oscillator

2.4 Circuit Diagram

The hardware consists of PIC16F73 microcontroller, HC-SR04 ultrasonic sensor, SIM900A GSM module, IC7805 voltage regulator, resister, capacitor and a crystal oscillator. PIC16F73 is a CMOS-FLASH based 8 bit microcontroller. It has got two 8 bit and one 16 bit timer/counter. We have used timer 1 for connecting the ultrasonic sensor HC-SR04 with the microcontroller.

This microcontroller is also equipped with Tx and Rx pin for serial communication. These pins are connected to the GSM module through the inbuilt MAX 232IC present at the module. MAX 232IC serves to convert the logic from TTL to RS232 logic, as the GSM module operates at RS232 while PIC16F73 microcontroller at TTL logic. The circuit diagram is shown below in the diagram.

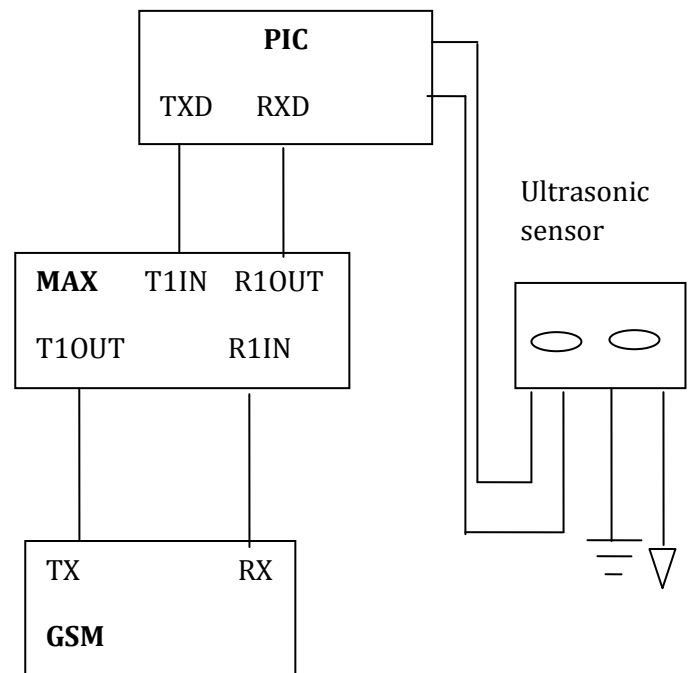

Fig - 1: Circuit Diagram of Smart Dust Bin

The ultrasonic sensor used here has two pins: Trigger and Echo, which are used for calculating the distance of the object by generating sound waves and thus calculating the time duration of the echo that is generated. A high to low signal by the microcontroller at the trigger pin of the sensor sends eight 40 kHz sound waves, after which the ECHO pin is turned high until when the echo of the sound waves echoed back to the sensor.

The ECHO pin which is being connected to the C3 pin of the PIC16F73 microcontroller is continuously monitored to detect its status. The timer1 of the microcontroller is used for the purpose of calculating the time period for the sound wave to travel back to the sensor. Then, the calculated time can be computed through the following equation into the distance (cm) unit.

$$D = \{(t*v)/2\}*100 \dots\dots\dots (1)$$

In (1), we have 'D' as the distance in cm measured by the ultrasonic sensor, 't' is the time taken by the sound wave to echo back to the receiver in seconds, 'v' is the velocity of sound wave. Thus, this equation is computed by the microcontroller and we can get the distance of any solid waste material present in the bin. The GSM module connected to microcontroller sends this garbage level in the form of text message to the central waste office. The GSM module has got a unique SIM card and a unique

number, which acts as a unique ID for the respective smart bin.

As we know, the large bins are present in each locality and serve as the centre point of garbage of that particular locality. The garbage collection team collects the garbage from these central bins in their trucks. Our model of hardware is going to be applied in these central bins and thus making them smart bins. For this we have divided the dustbin into three different levels according to the level of garbage filled.

Accordingly, the text messages indicating the levels are being sent to the central office, which acts as a data warehouse for all the level data being sent by the different bins. The central office of waste management department now will be able to track the level of every dustbin getting filled up just by sitting in their office at real time. This information will now guide them efficiently to take up the action of sending the trucks to empty the dustbin whose levels are significant. The hardware has used some very basic electronic components to make out the complete system at the best possible cost. The built hardware can be implemented at any dustbin irrespective of its size and height and thus is portable with any bins.

3. SOFTWARE AND ANALYSIS

Every smart bin is equipped with ultrasonic sensors which measure the level of dustbin being filled up. The container is divided into three levels of garbage being collected in it. With its continuous use the levels get filled up gradually with time. Every time the garbage crosses a level the sensors receives the data of the filled level. This data is further send to the garbage analyzer as instant message using GSM module. Every message which is received at the garbage analyzer end is being saved as data which is further used for the process of analysis and predictive modeling. The data received at real time is used by the application interface for better viewing of the filled level.

The data received is saved in the database keeping all its attributes intact as time and date. A history of data collected in months is used by the department of data analysis for prediction and report making. The application interface shows the real time level to the garbage analyzer and using that it directs its team of garbage collector to collect the garbage to avoid overflow.

The prediction model is designed to predict the time in which the every level of container will be filled in future. This will help the waste management department to optimize the route for the collection of

waste every time garbage collector moves around the city for garbage collection. This helps in saving time, resources of the waste department and work is then performed in more efficient manner.

3.1 Real Time Interface

The real time view of the filled level of every container is developed in Microsoft Excel. The dynamic reporting technique in Excel helped us develop this interface. Every level the dustbin gets filled up is received at the interface end using message service. This message received is taken in the form of text files which is connected to the excel sheet showing the filled level of very container. SMS received from the GSM modules of our dustbin is taken in the form of text files. The text file in connected to the excel sheets. The updated values of the dustbin level are taken to form the real time report.

The updated values from the excel sheet is taken using various excel function like IFERROR, LARGE, INDEX, IF, COUNTIF and ROW. The widget is developed using charts in excel. The Doughnut chart is the indicator of all three levels. The pie chart is used to make the pointer that moves accordingly as levels the dust bin gets filled in real time. The color coding of the levels is done as: Yellow for level 1, Green for level 2 and Red for level 3. The excel application designed creates a real time dashboard along with a time series graph which shows the current trend as well as the historical trend of waste level in that particular smart bin.

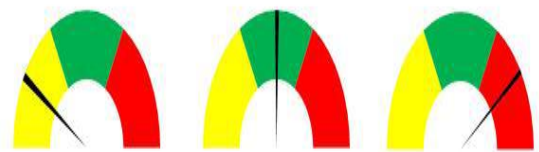

Fig - 2 : Capacitor Indicator

The map of the city will be used in the application interface and these widgets marking the level of dustbin filled will be put in the location in map exactly the way dustbins are placed throughout the city. This will help the garbage analyzer to keep a track of dustbin filled in exact location. Thus our application will help the garbage analyzer to keep a check on every dustbin throughout city at real time. It will help him taking accurate decision and avoid the overflow of dustbins and use the resources more efficiently. These multiple smart bin model can be applied to any of the smart cities around the world.

A waste collecting team which is deployed for collection of garbage from the city can be guided in a well manner for collection. The application will serve as a central application for the person responsible for monitoring the waste status across the city. The model interface in excel is made as shown below, it is completely dynamic in nature and is well connected with the respective dataset generated by the bins.

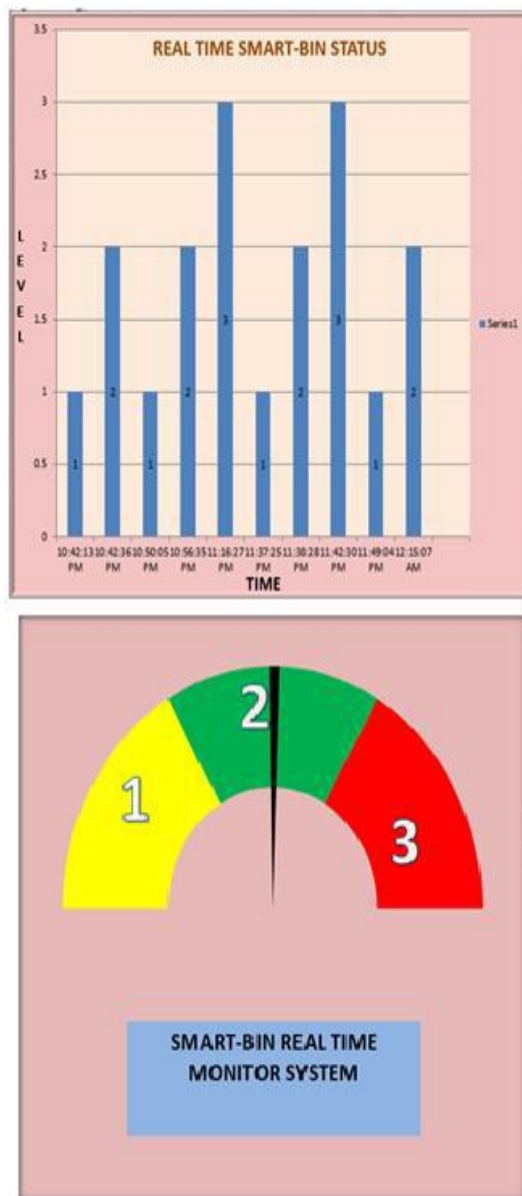

Fig - 3 : Smart Bin Real-time Monitor System

The dataset contains different variables of which "ID", is the unique ID of a bin, and is the primary

key. Our smart-bin sends us the message which contains the updated level of garbage along with the Date and Time stamp. The other factors like Location of the smart-bin and Full or not status is included using SQL joints and Excel spreadsheet functions. The main aim of our smart-bin's data analysis is to create a prediction model which can predict the time a particular smart-bin will be getting filled up.

We can use the concept of Machine Learning in order to train our prediction model with the available historical dataset generated in the given time period. In order to check the predictive model, we can divide the dataset into training and testing data set. The goal will be to predict "Full" and "Almost" status, i.e. Level 3 and Level 2 or 3 respectively. With large amount of dataset produced, a larger accuracy can be obtained and thus a trend in the waste generation can be known effectively based on factors like locality, time, day of the week etc. Moreover, with the historical dataset, we will be able to figure out the average time it takes a smart-bin to get filled up totally and the average time it takes to gain a single level. Now, this analysis can be used in building up the algorithm for route planning by predicting the fill due date of each bin based on their last updated level. We will be using the following variables for the algorithm.

3.2 Route Optimization Algorithm

$i, k = 1, 2 \dots n$, ID of n number of smart-bins

L_i = Current Level of the i th smart-bin.

t_i = Time for which the i th bin is filled up totally.

ak_1 = Average time for k th smart-bin to get filled 1 level up.

It is computed through analysis of a month's data

for each Bin.

ak_3 = Average time for k th smart bin to get filled up completely. It

is computed through analysis of a month's data for each Bin.

$Tk[L_k, tk]$ = Array which consist the last updated level

and time of every smart-bin in the network.

Result: Predicted percentage filled status of every Smart-bin and thus estimate the optimal route based on potential filled Bins.

Begin

for $i=1$ to n **do**

If $Li==3$ **then** // Compare Li with 3 to check if i th bin is full or not.

for $k=1$ to n **do**

if $k!=i$ **then**

$qk = Tk[1]+(3-Tk[0])ak1$ //

Compute the expected

time for every k th

smart-bin to get full.

$pk = qk - Ti$ // Compute the

time required more to get full by the k th smart-bin.

if $pk \leq 0$ **then** //

Check if k th bin is already filled.

$f(b)=k$ // Store ID of k th smart-bin in an array.

else if $pk > 0$ **then**

$prk = [(ak3 - pk) / ak3] * 100$

//Compute the predicted current percentage level

endfor $b=0$ to length($f(b)$) **do** | Action

= create optimized route in the map

from the smart-bin ID in $f(b)$ array

end

end

end

return Action;

if $prk > 65$ **then**

//The threshold percentage is

considered as 65

$f(b)=k$ // Store ID of k th smart-bin in an array.

end

end

4.DATA MINING IMPLEMENTATION

4.1 Prediction Of Time Series

Prediction of an event at a time series is quite important for engineering and economy Problems. Time series data mining combines the fields of time series analysis and data mining techniques. This

method creates a set of methods that reveal hidden temporal patterns that are characteristic and predictive of time series events. Time series data mining examines the time series in a phase space. Time series has been transformed to phase space by using nonlinear time series analysis and then fuzzy logic has been used to prediction optimal values of important parameters characterizing the time series events. Truth of prediction algorithm based fuzzy logic has been proved by application results.

A time series example has been given in equation (2).

$$X = \{x, t_1, \dots, N\} \dots \dots \dots (2)$$

Where t is time index and N is the total number of observations.

An event characterization function $g(t)$ can be employed to characterize the event in equation (2) as shown in equation (3).

$$g(t) = g(x, x_t, x_{t_1}, \dots, x_1) \dots \dots \dots (3)$$

This event characterization function changes according to the prediction aim. For example, if x_t represents level completed in the dust bin and our aim is to predict the time when the next level would be completed, then the event characterization function can be defined as shown in equation (4). The event characterization function is defined such that its value at t time index correlates highly with the occurrence of an event at some specified time in the future.

$$g(t) = \frac{X_{t+1} - X_t}{X_t} \dots \dots \dots (4)$$

$$g(t) = x_{t+1} \dots \dots \dots (5)$$

Before the event characterization function is determined, the aim is to select this function which predicts important events.

This is not trivial task due to nonlinear behaviors of most time series in the real world applications. An important disadvantage in time series analysis is that the time series should be converted to stationary and periodic series in order to analyze it. As an emerging discipline, data mining is the process of discovering hidden and useful information from huge

data. Data mining is defined as extracting useful and meaningful information using statistic, machine learning, artificial intelligence and pattern recognition techniques from large data sets.

Data mining is the analysis of data with the goal of uncovering hidden patterns. Weiss and Indurkha defined data mining as “the search for valuable information in large volumes of data”. Time series data mining combines data mining and nonlinear time series analysis to analyze a time series. When data mining is applied to time series data, an event is considered as an interesting pattern. Povinelli defines time series data mining as “combining of data mining, time series analysis and genetic algorithm techniques”.

He used the genetic algorithm to discover interesting patterns in a time series by data mining. Time series should be examined in a phase space in order to get interesting pattern from it. The main goal in time series data mining is to use time delay embedding and phase space based on Taken theorem.

The phase space of a time series in equation (2) is generated by using time delay embedding and embedding dimension in order to get interesting patterns. Elements of X_t form time lagged shape of original time series with embedding dimension b and time delay factor τ . The phase space of the time series in equation (2) according to time delay factor τ and embedding dimension b is presented in equation (6). X is a matrix whose row vector is a point in the phase space.

$$X_t = (X_{t-(b-1)\tau}, X_{t-(b-2)\tau}, \dots, X_t) \in R^b \dots\dots\dots(6)$$

Where $\tau = 1, 2, \dots, k$ is time delay embedding which allows the phase space to be spanned over nonconsecutive time lagged instances. The temporal patterns representing the characteristic of time series are used to prediction of the important events. This method is successfully applied non-periodical, nonlinear, and complex time series. Data mining is the process of discovering useful pattern in data that are hidden and important pattern. It comes from several fields, including statistics, database and machine learning. It uses techniques such as clustering, association rules, and classifications models to identify hidden and useful information in large databases. Others who have applied data mining concepts to finding patterns in time series include Keogh and Smyth.

Their approach uses a dynamic programming method for aligning the time series and a predefined

set of templates. Moon et al. proposed a new time subsequence matching method. They used the dual match for time series similarity. Time series data mining has been used in a lot of fields such as clustering and event prediction in literature. One of these methods is classification and fault diagnosis in induction motors. Povinelli was suggested an application in order to event prediction. In his study, he did different applications such as earthquake prediction, sharp fall of stock price.

At first step, he transformed a time series to phase space. He selected different event characterization functions for each application. Optimal temporal pattern cluster with radius r and temporal pattern center v was found by using genetic search algorithm. Despite the novelty of this method, several problems limited its applications and must to be addressed. First, temporal pattern cluster in this study was defined by a rigid region with fixed center and radius.

This restriction made it hard to adjust to the situation when there is noise in phase space and often generated high degree false-positive prediction. The second disadvantage is the computational complexity and stability. The genetic algorithm yields heavy computing load. The optimization results were often inconsistent. The choices of embedding dimension b and time delay τ were always based on user's experience with trial-and-error. Feng et al. suggested new time series data mining for identifying temporal patterns.

Temporal pattern cluster was chosen as a fuzzy set with Gaussian shaped membership function. An efficient two step optimization strategy was proposed to search the optimal temporal cluster in the phase space. Time delay embedding τ and embedding dimension b is chosen by mutual information and false nearest neighbor method, respectively.

Gradient descent optimization algorithm is chosen in order to find optimum temporal pattern cluster. Multilayer feed forward neural network was performed on the D-stock prediction. The goal was predicted next day's closing price change, with the input of today as well as four previous day's price change. In this paper, proposed time series data mining method is based on fuzzy logic. This method uses the fuzzy logic for earthquake and Lorenz series prediction. Therefore, event prediction doesn't include complex mathematical equations and the prediction is simplified.

The prediction is flexible due to property of fuzzy logic method. Because temporal pattern cluster is

selected as a fuzzy set, each of point in temporal pattern cluster belong to cluster with a specific membership degree. So the event prediction is predicted accurately. The heavy load which the genetic algorithm yields is removed. Because user experience about event prediction is shown in phase space and augmented phase space easily, the fuzzy rules is also determined, easily.

4.2 Applications Of Time Series Data Mining

Data mining is a technique of discovering useful pattern in data that are hidden and unknown in normal circumstance. Data mining consist of machine learning, statistics and database design. It uses methods such as clustering, classification, association rule mining and probabilistic graphical dependency models to identify hidden and useful information from large databases.

Predictive data mining is a search for very strong patterns in big data that can generalize to accurate future decisions. Data mining refers to extracting or “mining” knowledge from large amounts of data. Keogh et al. used piecewise linear approximation representation of time series for clustering, classification and association rule mining of time series data.

They have examined the first extensive review and empirical comparison of time series segmentation algorithms from a data mining perspective. They have developed an efficient sequential pattern for identifying frequent temporal patterns. Faloutus et al. have developed efficient time series similarity search methods namely subsequence matching. Povinelli et al have proposed a new signal analysis and classification method based on reconstructed phase space.

They have used statistical method to estimate of phase space. Bayesian likelihood and artificial neural network World Academy of Science, Engineering and Technology 51 2009 92 have been used for classification and compared two techniques. Feng et al. have proposed fuzzy set and the Gaussian shaped membership function to define temporal patterns in time delay embedding phase space.

5. DETECTING WASTES USING SENSORS

5.1 System Model

There are three subsystems in AMS.

They are:-

- Singling
- Sensor
- Discharge Unit

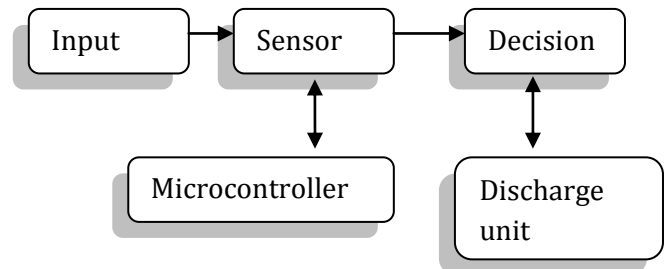

Fig – 4: AMS System Model

The singling unit consists of vibration feeder driven by a vibrating motor by which the mass flow of pre-processed waste particles has been isolated from rebounding and passes vibration feeder. So that it comes to lie on the bifurcated sheet in a controlled way which leads directly to the sensor unit. The sensor unit contains one or more sensors to detect specific attributes of all particles in the mass flow.

The particles have to stay in a fixed position relatively to the surface of bifurcation tray; apparently their position is predictable in order to detect the waste particles by using regional sensors which is placed in a bifurcation tray. Once the waste materials have been sensed by the sensor unit, a specific signal is transmitted to the microcontroller unit. The discharge unit consists of three ports such as organic, inorganic and reusable it is regulates by the microcontroller with the reference of received signal.

The sensor detects the waste material based on its intensity and wavelength. Once the material is sensed a specific signal is passed towards the microcontroller for the analysis. The signal will be converted into digital signal by analog to digital converter (ADC). The digital signal is then passed to the microcontroller for certain diagnosis. A micro controller analyses the sensor data in a split of a second. After interpretation, the received spectrum of specific radiation of materials is classified to be separated.

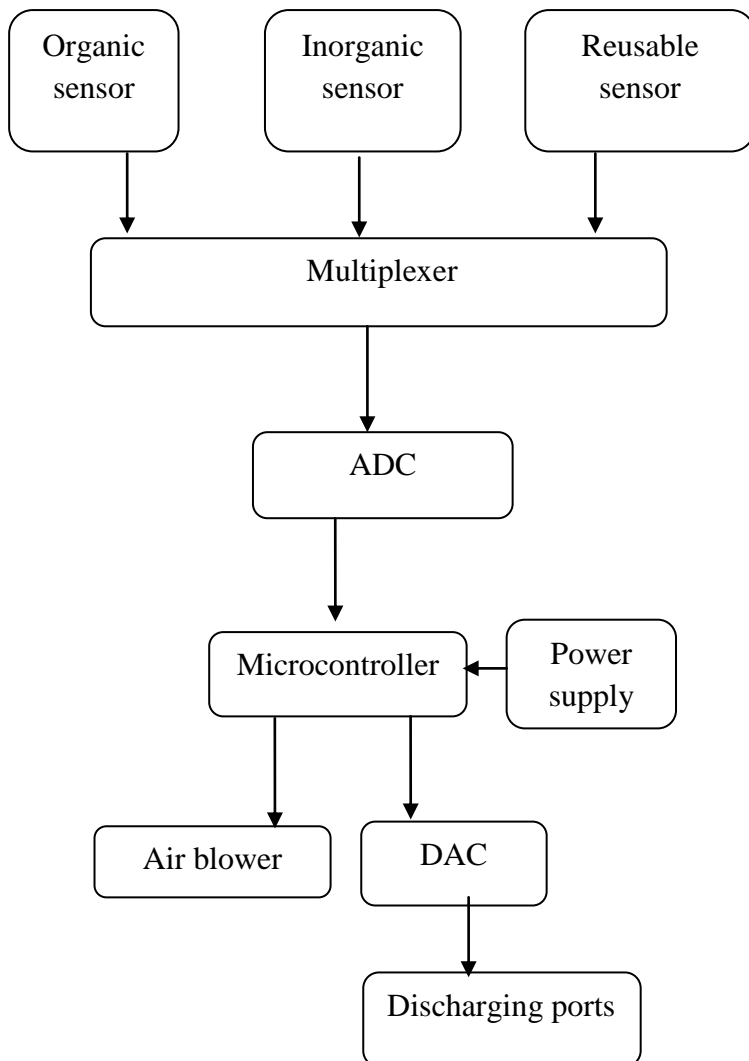

Fig - 5: Implementation of AMS model

The analyzed signal being a digital signal is converted into analog using DAC. The analog signal makes the discharging doors to recognize the corresponding waste and thrashes it into their respective slots. The air blower makes the use of discharging the waste that have not sensed. The AMS bin is a multi sensor system which might be necessary to perform a successful classification of different type of materials.

5.2 Algorithm For Separation Of Waste

- Step 1:** In the time 't₀'
"SWITCH ON" Vibrating motor in both feeder and tray
- Step 2:** In the time 't₂'
"SWITCH ON" the air blower in the bin

- Step 3:** In the time 't₃'
"SWITCH ON" the electromagnet for detecting reusable materials
In the time 't₄'
Open the door corresponding to reusable
In the time 't₅'
Materials demagnetize from the door
In the time 't₆'
Close the door
- Step 4:** In the time 't₇'
"SWITCH ON" all the Sensors in the bifurcation tray
If (organic sensors detect the material)
Open the corresponding organic door
Else if (inorganic sensors detect the materials)
Open the corresponding inorganic door
In the time 't₈'
Close all the doors
- Step 5:** In the time 't₉'
System "SHUT DOWN"

In AMS method, the Entire process can be done within duration of 6 minutes. When the power supply is given to the IMS bin, the vibrating motors in both the feeder and bifurcation tray get ('t₀'). In the next minute ('t₁'), the air blower will blow of the light weight materials like paper, carton. And the blower will switch off within 60 seconds. Then the electromagnet will be switched on for the next 30seconds (t₃) to segregate the Ferro magnetic materials from cluster of waste. It is demagnetized while the electromagnet door opens in the time period of 't₄'.

In the consecutive time period, AMS bin gets switched on and starts sensing the sensor in the waste particles. If the waste particle is identified by moisture sensor or humidity sensor in a particular time span it is said to be organic. In case if it is identified by the photo electric sensor, in either in the same time period, said to be inorganic. Finally 5 to 6 minutes the waste materials are sorted out hence it saves the environment.

5. CONCLUSION

Urbanization is at its rapid growth stage around the world, as more number of people desires to

live in the city lights with more opportunities for growth and success. Cities are expanding like never before to accommodate this growth and in this process the concept of smart cities came into action.

The parameters like cleanliness and hygiene are the topic of concern in these smart cities and concrete measures should be taken for that. Also, the growth should go hand in hand with the green environment and research should be further done on such technology. Our work is a small but efficient step towards cleanliness.

We have successfully made and tested the model of our smart dust bin so we believe with encouragement from the side of government we can successfully transform this model into product.

REFERENCES

1. "Recycling is Garbage" by John Tierney. The New York Times, June 30, 1996. Almost 20 years on, Tierney updated his figures but essentially made the same argument again in The Reign of Recycling, The New York Times, October 3, 2015. Readers responded the following week in Where Our Trash Goes, The New York Times, October 10, 2015.
2. US EPA: Recycling: Basic information: The main EPA website about how to recycle things, including what happens to recycled materials and other ways of reusing things (such as donating used electronic equipment to good causes).
3. Recycling still the most effective waste disposal method, report finds by Juliette Jowit, The Guardian, 16 March 2010.
4. Does recycling reduce carbon emissions? by Local Government Improvement and Development, 20 July 2010.
5. Michael Alexander, John Walkenbach, "Microsoft Excel Dashboards & Reports", Wiley; Second edition, 28 June 2013. (Book style)
6. Yann Glouche, Paul Couderc. A Smart Waste Management with Self-Describing objects. Leister, Wolfgang and Jeung, Hoyoung and Koskelainen, Petri. The Second International Conference on Smart Systems, Devices and Technologies (SMART'13), Jun 2013, Rome, Italy.2013. (Conference proceedings)
7. Foday Pinka Sankoh, Xiangbin Yan, Quangyen Tran on "Environmental and Health Impact of Solid Waste Disposal in Developing Cities: A Case Study of Granville Brook Dumpsite, Freetown, Sierra Leone," on Journal of Environmental Protection, 2013, 4, 665-670. (Journal or magazine citation)
8. Michael Batty, Kay Axhausen, et al., "Smart Cities of the Future," UCL centre for advanced spatial analysis on working paper series, ISSN 1467-1298, Paper 188 - Oct 12.
9. Ron Zacharski. A Programmer's Guide to Data Mining. Available: <http://guidetodatamining.com>.
10. Yang Kai, Zhang Junmei, Li Wenbin, Yang Liu, GaoLin, XueHuixia, "Weighing System of Fruit-Transportation Gyrocar Based on ARM" IEEE computer society, 2011 DOI 10.1109/ICMTMA.2011.253.
11. Arebey M., Hannan, M.A.; Basri, H.; Abdullah, H. "Solid waste monitoring and management using RFID, GIS and GSM" IEEE Student Conference on Research and Development (SCORED), 2009.
12. Arebey, M.; Hannan, M.A.; Basri, H.; Begum, R.A., "Solid waste monitoring system integration based on RFID, GPS and camera", IEEE International Conference on Intelligent and Advanced Systems (ICIAS), 2010.
13. Islam, M.S.; Arebey, M.; Hannan, M.A.; Basri, H., "Overview for solid waste bin monitoring and collection system", IEEE International Conference on Innovation Management and Technology Research (ICIMTR), 2012.
14. Alberto Rovetta, Fan Xiumin, c, Federico Vicentini, , Zhu Minghuab, c, Alessandro Giustia, He Qichang "Early detection and evaluation of waste through sensorized containers for a collection monitoring application" Science Direct Journal.
15. Issac, R.; Akshai, M. "An effective solid waste management system for Thiruvalla Municipality in Android OS" IEEE Conference Publications, 2013
16. Longhi, S.; Marziani, D.; Alidori, E.; Di Buo, G.; Pris, M.; Grisostomi, M.; Pirro, M. "Solid Waste Management Architecture Using Wireless Sensor Network Technology", New Technology, Mobility and Security (NTMS), 2012 5th International Conference.
17. Chen Tao; Li Xiang, "Municipal Solid Waste Recycle Management Information Platform Based On Internet of Things Technology", Multimedia Information Networking and Security (MINES), 2010 International Conference.
18. The Free Dictionary by Farlex, 2010
19. Folorunso O and Ogunde A O, Data Mining as a technique for knowledge management in business process redesign, The Electronic Journal of

- Knowledge Management, 2(1) (2004) 33-44, Available online at:www.ejkm.com.
20. Han, J. and M. Kamber, Data Mining: Concepts and Techniques, Morgan Kaufmann, 2001.
 21. Larose D T, Discovering knowledge in data: an introduction to data mining, (John Wiley; New York), 2005.
 22. Bakar AA, Febriyani F. Rough Neural Network Model for Tuberculosis Patient Categorization. In: Proceedings of the International Conference on Electrical Engineering and Informatics; 2007; Indonesia. p. 765-768.
 23. Manual on Solid Waste Management, Ministry of Urban Development and Poverty Alleviation, Government of India Publications, New Delhi.(2003).
 24. Draft Report of Core Group on Appropriate Technology, Research and Development (SWM), Technology Advisory Group and Ministry of Urban Development and Poverty Alleviation, Government of India, New Delhi. MOUD Report (2005).
 25. Management of Solid Waste in Indian Cities, Ministry of Urban Development, Government of India, New Delhi. NEERI (1995). 'Strategy Paper on SWM in India', National Environmental Engineering Research Institute, Nagpur.
 26. OECD (1995). OECD Environmental Data Compendium 1995,OECD, Paris.SC (1999).
 27. Report of the Supreme Court Appointed Committee on Solid Waste Management in Class I Cities in India, Supreme Court of India, New Delhi.
 28. World Bank (1997a). What a Waste, World Bank, Washington, DC. (1997b). Per Capita Solid Waste Generation in Developed Nations, World Bank, Washington, DC.(1999).
 29. What a Waste: Solid Waste Management in Asia, World Bank, Washington, DC.
 30. The Expert Committee, 2000. *Manual on Municipal Solid Waste Management*. The Ministry of Urban Development, the Government of India volume 1 and volume
 31. <http://ijrest.net/downloads/volume-3/special-issue/nrcrtct-16/pid-ijrest-3s1ncrtct2016028.pdf>
 32. Sánchez MA, Uremovich S, Acrogliano P. Mining Tuberculosis Data. In: Berka P, Rauch J, Zighed DA, editors.Data Mining and Medical Knowledge Management: Cases and Applications. New York: Medical Information Science Reference; 2009.
 33. Atiq Islam, Syed M. S. Reza, and Khan M. Iftekharuddin, Senior Member, IEEE, "Multifractal Texture Estimation for Detection and Segmentation of Brain Tumors" IEEE Transactions on Biomedical Engineering, VOL. 60, NO. 11, NOVEMBER 2013.
 34. T.Rajesh, R. Suja Mani Malar "Rough Set Theory and Feed Forward Neural Network Based Brain Tumor Detection in Magnetic Resonance Images" Proceedings of the International Conference on Advanced Nanomaterials & Emerging Engineering Technologies" (ICANMEET-20 13).
 35. Abdul Kalam Abdul salam,"Assessment on brain Tumour Detection using Rough set Theory" International Journal of Advance Research in Computer Science and Management Studies,Volume 3, Issue 1, January 2015.
 36. ShusakuTsumoto and Shoji Hirano, –Temporal Data Mining in Hospital Information Systems||. [11] Arun K Punjari, –Data Mining Techniques||, Universities (India) Press Private Limited, 2006.
 37. Margaret H.Dunham, –Data Mining Introductory and Advanced Topics, Pearson Education (Singapore) Pte.Ltd.,India. 2005.
 38. PrasannaDesikan, Kuo-Wei Hsu, JaideepSrivastava, –Data Mining For Healthcare Management||, 2011SIAM International Conference on Data Mining, April, 2011.

BIOGRAPHY



1. **Mrs. V.Priyavadana** MCA,MPhil, Research Scholar, Department of Computer Science, D.K.M. College for Women (Autonomous), Vellore, TamilNadu, India