

Simulation of Perturb & Observe (P & O) MPPT Technique for PV Micro-Grid System Using MATLAB/SIMULINKS

Miss. Sai Saymote

Department of Electrical Engineering
Annasaheb Dange College of Engineering & Technology
Ashta
Shivaji University, Kolhapur

Prof. Y. R. Atre

Department of Electrical Engineering
Annasaheb Dange College of Engineering & Technology
Ashta
Shivaji University, Kolhapur

Abstract - In this paper P & O MPPT algorithm for PV model is proposed. The main aim of project is to make the panel to rotate according to the sun's direction from morning to evening instinctively so that the panel grabs the solar energy to maximum extent possible throughout the day. If we could configure a solar cell so that it faces the sun continually as it moves across the sky from east to west, we could get the high electrical energy possible so we use P & O MPPT technique for improving efficiency. The complete system is modeled and simulated in the MATLAB/SIMULINK.

Key Words: Maximum Power Point Tracking, Photovoltaic, Perturb and Observe, Solar irradiance, MATLAB.

1. INTRODUCTION

Due to the concerns of global warming, environmental pollution, and the instability of oil prices, the development of renewable energy is based Distributed Generation (DG) is moving fast to meet the worldwide urgent needs of utilizing clean energy sources and minimizing costs. Researchers have identified many renewable energy sources. Among these sources, photovoltaic (PV) can be considered the most essential resource because of the ubiquity, abundance, and sustainability of solar radiant energy. The sun radiates approximately 1.8×10^{17} of power that is intercepted by the Earth. One method of utilizing solar energy is through PV cells in the form of electrical energy. A group of cells forms a PV module and a combination of PV modules is called a solar panel, while a group of solar panels is called a PV array. A photovoltaic system consists of the whole assembly of the solar cells, connections, protective parts etc. The advantages of a PV system far outweigh its disadvantages.

Each day, the sun rises in the east, moves toward the sky, and sets in the west. Whenever the sun is shining on us, it is sending an energy in our direction. We can feel the heat from the sun, and we can see objects that are illuminated by the light from the sun as it moves toward the sky. However,

if we could get a solar cell to turn and look at the sun all day, then it would be getting the maximum amount of sunlight possible and converting it into the more useful energy form an electricity. If we are located in the tropics, we see that the sun appears to follow a path that is nearly directly overhead. However, for the locations north or south of the tropics (e.g., latitudes greater than 23.5 degrees), the sun never reaches the position that is directly overhead. Instead, it follows a path across the southern or the northern part of the sky.

The difficulty here is that the sun's position is not constant throughout the day. The output from the solar system depends on an intensity of sunlight and the angle at which radiation is being incident. Hence there is a need to track the sun in order to produce maximum output throughout the day. The solution to the problem is "Perturb & Observe Maximum Power Point Tracking Technique". For the improving an efficiency of PV system P & O MPPT technique is used.

2. LITURATRE SURVEY

The major motivation to this work is done by Huan-Liang Tsai, Ci-Siang Tu, and Yi-Jie Su. This paper presents the implementation of a generalized the photovoltaic model using MATLAB/SIMULINK software package, which can be representative of PV cell, module, and array for an easy use on simulation platform. The proposed model is designed with user friendly icon and a dialog box like the Simulink block libraries. This makes the generalized PV model easily simulated and analyzed in conjunction in power electronics for a maximum power point tracker. Taking the effect of sunlight irradiance and cell temperature into the consideration, the output current and power characteristics of PV model are simulated and optimized using proposed model. This enables dynamics of PV power system to be easily simulated analyzed and optimized [1].

The major motivation to this work is done by Chen Qi, Zhu Ming. In this paper, a modified P&O MPPT technique, applicable for the PV systems, is presented. The proposed technique achieves: first, adaptive tracking; second, no steady-state an oscillations around the MPP, and lastly, no need for the predefined system-dependent constants, hence

providing a generic design core. A design example is presented by an experimental implementation of proposed technique. Practical results for an implemented setup at different irradiance level are illustrated to validate proposed technique [2].

The major motivation to this work is done by Samer Alsadi, Basim Alsayid. This paper presents a new maximum power point tracking algorithm is based on the current control for a single stage grid connected photovoltaic system. A variable step size for the change in reference amplitude during an initial tracking helps in fast tracking. The proposed algorithm prevents the PV system from an entering the positive slope region of the $p-v$ characteristics. It is also capable of restoring stability if the system goes to unstable due to a sudden environmental change [3].

The major motivation to this work is done by Jay Patel, Gaurag Sharma. This paper proposes design of photo voltaic system, simple boost converter, perturbation and an observation (P&O), improved perturbation and observation (IP&O). A Matlab/Simulink based simulation study of the PV cell/PV module/PV array is carried out and presented [4].

The major motivation to this work is done by Ajay Patel, Vikas Kumar, Yogendra Kumar. This paper gives the information about the microcontroller based photovoltaic maximum power point tracking control system. A new MPPT system had developed, consisting of the Buck-type dc/dc converter, which is controlled by a microcontroller-based unit. The PV array output power delivered to the load was maximized using MPPT control systems, which consisted of a power conditioner to interface the PV output to the load, and a control unit, which is drove the power conditioner such that it extracted the maximum power from a PV array [5].

The major motivation to this work is done by Ioan Viroel BANU, Razvan BENIUGA, Marcel ISTRATE. In this paper, The comparison between perturb and observe an incremental conductance is done. This paper gives proper information about difference between P & O mppt technique [6].

The major motivation to this work is done by Gangavarapu Mamatha. This paper gives the information about implementation of perturb and observe MPPT Technique. Author had given a microprocessor based automatic position control scheme. They had designed for controlling an azimuth angle of an optimally tilted photovoltaic flat type solar panel or a cylindrical parabolic reflector to get an illuminating surface appropriately positioned for the collection of maximum solar irradiance. The proposed system is resulted in saving of energy .Temporal variations in environmental parameters caused by fog, rain etc., at the distance from the location where panel was mounted, did not affect proper direction finding [7].

3. NEED OF THIS WORK

This project will help for improving efficiency of PV system as it moves with sun direction. This system can supply rural areas that have no electricity grid. Thus, all around the world, solar photovoltaic energy provides people who are too isolated to be connected to conventional electricity grids the means for development. This method is useful in slow changing or constant weather conditions for obtaining maximum power.

4. SYSTEM CONFUGERATION

The main objective of this paper is the model, analyze, and conduct case studies on a P & O MPPT technique used for PV system. This system contain PV cell, P & O MPPT technique, DC-DC boost converter, Inverter. The following sections describe each block in the figure.4.

5. EQUIVALENT CIRCUIT OF PV SOLAR CELL

The solar cell is the basic unit of the PV system. Solar cell or photovoltaic (PV) cell is a device that is made up of semiconductor materials such as the silicon, gallium, arsenide etc. that converts sunlight directly into electricity. The voltage of the solar cell does not depend upon only solar irradiance but also on cell temperature. PV modules can be designed to operate at distinct voltages by connecting solar cells in series. When solar cells absorb sunlight, free electrons and holes are created at a positive and negative junctions. If the positive and negative junctions of solar cells are connected to the DC electrical equipment, current is delivered to operate the electrical equipment.

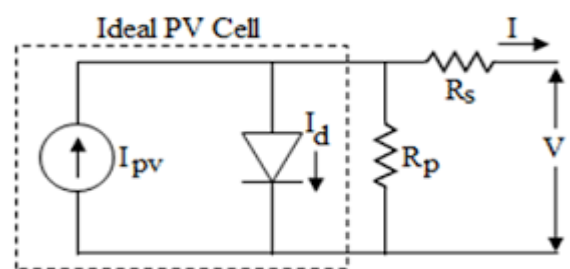

Fig-1: Equivalent circuite of PV cell

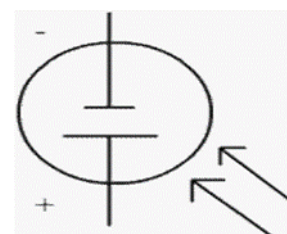

Fig-2: Systematic symbol of PV cell

The output current is given by- $I = I_{pv} - I_d$

Where, I_{pv} = photon current produced by cell

I_d = diode current

The diode current I_d is given by $I_d = I_o [\exp (qV_d/kT) - 1]$

I_o : reverse saturation current of diode,

q : elementary electron charge (1.602×10^{-19} C),

V_d : diode voltage,

k : Boltzmann constant 1.381×10^{-23} (J/K)

T : temperature in kelvin (K)

An equation represents about solar cell- $I = I_{pv} - I_o [\exp (qV_d/kT) - 1]$

Where V_d is the output voltage of the PV cell.

6. PERTURB & OBSERVE MPPT TECHNIQUE

The P&O algorithm is the most widely used for MPPT solar PV cell, also known as hill climbing method. This algorithm has very simple arrangement and the small measured parameters. In this algorithm the module voltage is continuously perturbed and compared with previous voltage. A slight perturbation is introduced in this method. Due to this perturbation the power of the module changes. If the power increases then perturbation is continued in that direction. After reaching at peak point the power at the MPP is zero and then decreases hence the perturbation reverses in that direction. The developed designs can be modeled using Matlab and Simulink. The time complexity of this algorithm is very less. This method works best for slow changing or constant weather conditions. The algorithm flowchart is as shown in fig.3

Fig-3: Algorithm for P & O MPPT technique

7. DC-DC BOOST CONVERTER

A boost DC-DC converter is a necessary power electronics device to control DC voltage by boosting and maintaining an appropriate value for load. In theory a boost converter is made up of at least two semiconductor devices such as diode and transistor.

8. INVERTER

A DC/AC inverter is the device that converts an electrical power from DC to AC. The resulting AC power can be of any voltage and the frequency with the use of an appropriate transformers, switch in gland control circuits.

9. SIMULATION AND EXPERIMENTAL RESULTS

Simulation model for P & O MPPT Technique is as shown in figure 4. Output from PV panel is given to Matlab function block where we programmed P & O MPPT algorithm. Then output of this is given to DC-DC boost converter and it is connected to inverter which gives AC voltage and current. In fig. 5 we can see results. Red dot shows maximum power points.

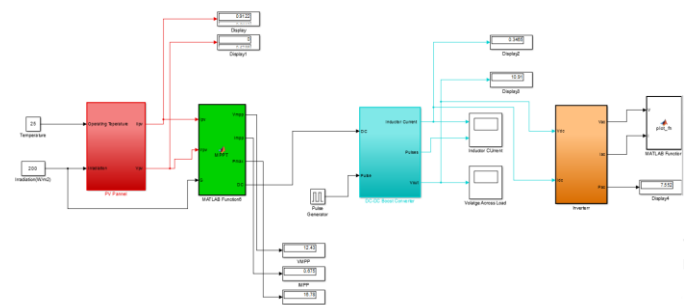

Fig-4: Simulation Model

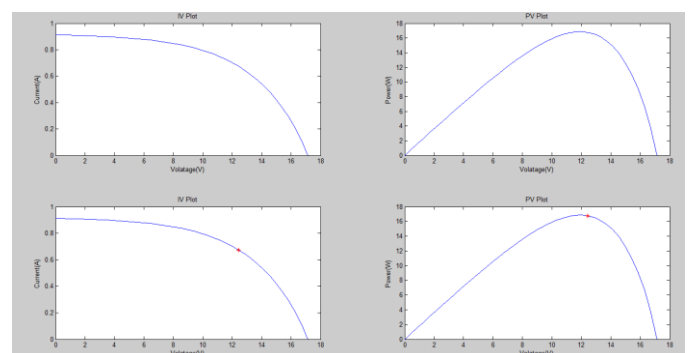
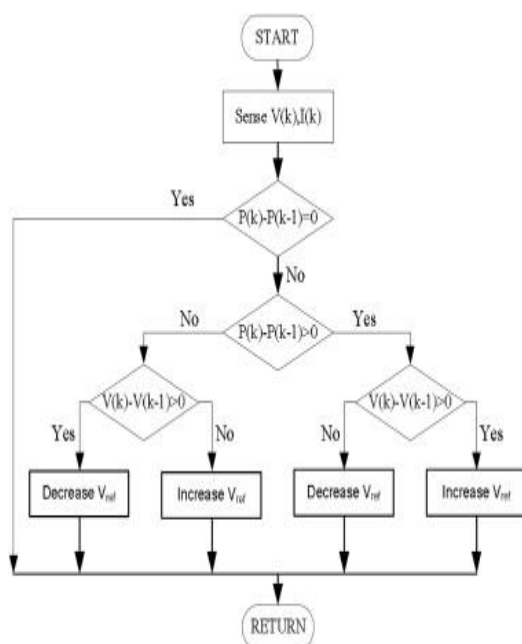

Fig-5: Result

10. CONCLUSIONS

The proposed work is done for design of P & O MPPT technique used in PV micro-grid for obtaining maximum power. The output power of the PV arrays is always changing with weather conditions, which mean solar irradiation and atmospheric temperature, so the use of the MPPT algorithms is required in order to obtain the maximum power from a solar array. P & O Maximum power point tracking technique improves the efficiency of the solar panel. Here all the simulations were done through MATLAB/Simulink.

11. FUTURE WORK

Modified Perturb and Observe method can be modeled for fast convergence speed and fast oscillations. This P & O MPPT Technique is good for slow changing or constant weather conditions.

ACKNOWLEDGEMENT

I would like to express my deep sense of gratitude towards my guide Prof. Y. R. Atre, Assistant Professor, Annasaheb Dange College of Engineering & Technology, Ashta, for his invaluable help and guidance for the project.

REFERENCES

[1] Huan-Liang Tsai, Ci-Siang Tu, and Yi-Jie Su, "Development of Generalized Photovoltaic Model Using MATLAB/SIMULINK," Proceedings of the World Congress on Engineering and Computer Science, San Francisco, CA, October 22-24, 2012.

[2] Chen Qi, Zhu Ming, "Photovoltaic Module Simulink Model for a Stand-alone PV system," 2012 International Conference on Applied Physics and Industrial Engineering 1875-3892© 2011 Published by Elsevier B.V. Selection.

[3] Samer Alsadi, Basim Alsayid, "Maximum Power Point Tracking Simulation for Photovoltaic Systems Using Perturb and Observe Algorithm," IJEIT Volume 2, Issue 6, December 2012.

[4] Jay Patel, Gaurag Sharma, "Modelling and Simulation of Solar Photovoltaic Module Using MATLAB/SIMULINK," Volume: 02 Issue: 03 March- 2013.

[5] Ajay Patel, Vikas Kumar, Yogendra Kumar, "Perturb and Observe Maximum Power Point Tracking for Photovoltaic cell," Vol. 4, No.6, 2013 International Conference on Recent Trends in Applied Sciences with Engineering Applications.

[6] Ioan Viroel BANU, Razvan BENIUGA, Marcel ISTRATE, "Comparative Analysis of the Perturb and Observe and Incremental Conductance MPPT Methods," 8th International Symposium on Advanced Topics in Electrical Engineering May 23-25, 2013.

[7] Gangavarapu Mamatha, "Perturb and Observe MPPT Algorithm Implementation for PV application," IJCSIT, Vol. 6(2), 2015.