

Wireless Controlled SPY ROBOT

R. B. Dhumale¹, N. D. Thombare², Vikas Sanjay Ojha³, P. M. Bangare⁴

^{1, 2, 3, 4} Sinhgad College of Engineering,
Pune, India

¹ rbd.scoe@gmail.com

² nilima_thombare@yahoo.co.in

Abstract - A new trend in robotics is smart phones that have a lot of sensors, camera, GPS. One of problems, however, is how to interface phone with custom electronics. It can be done over Bluetooth, but audio interfacing using dual tone modulation frequency DTMF is simpler. It is a simple moving platform containing mobile phone that is remote-controlled over Internet via Skype using DTMF tones. Wireless connection is done by WLAN that is free of charge or mobile phone network that can be done over large distance. The robot is capable to go in autonomous mode on a pre-defined track consisting of vertices made up of GPS. In this project, the robot is controlled by a mobile phone that makes a call to the mobile phone attached to the robot. In the course of a call, if any button is pressed, a tone corresponding to the button pressed is heard at the other end of the call. This tone is called 'dual-tone multiple-frequency' (DTMF) tone. The robot perceives this DTMF tone with the help of the phone stacked in the robot.

Key Words : GPS guided robot, DTMF technology, Global Positioning System.

1. INTRODUCTION

In this world of unprecedented Terrorism and not so trustworthy mankind, we need an artificial intelligence that can serve us in case of danger. Robotics is a new field in science that is growing a vast need in today's world. Robots are a staple in modern society. Their applications are far reaching and can encompass a variety of different missions. They are used in the manufacturing industry to perform repetitive or difficult tasks, in the military to travel and operate in dangerous areas, and in the medical industry to assist in procedures. There are a multitude of different situations where the use of a robot is a necessity, such as traveling in hazardous conditions where a human would be incapable of surviving or performing jobs that a human is unable to achieve without assistance. These robots can be either operated through the use of a remote system, or can be completely autonomous, capable of operating without any user input to accomplish a set of tasks. The advantage of an autonomous robot is that it doesn't need to be constantly monitored and controlled by a human operator, which allows people to complete multiple tasks simultaneously. The main goal of this project is to add a degree of autonomy

to an already functioning user controlled robot. Our project deals with making of one such. Our robot that we call "spy robot", can be controlled from a distant location using DTMF technology over skype. It will also send us live video of what it sees. And in addition to these it also has a self -controlled autonomous mode that helps it to navigate itself back to the controller person in case if signal lost, guided over GPS. The robot is controlled through our phone via making a skype call. The initiated skype call connects to the phone in our robot making it initiate a video call, thus we can see everything that's going on the other side of the user. The purpose of this project is to design and construct a robot capable navigating to a sequence of coordinates. This effect is to be accomplished using a global positioning system to allow the robot to become aware of its position on the earth and the positions of wave points relative to its current location. This device must be a robust vehicle capable of traveling outdoors on mostly flat ground and able to carry the load of what components are necessary for it to accomplish its function.

2. BLOCK DIAGRAM

Figure 1 illustrates the functional block diagram of the system that we are designing and implementing. In the initial stage we initiate a call from the laptop to the cell phone attached to the robot. Our robot is controlled through our phone via making a skype call. The initiated skype call connects to the phone in our robot making it initiate a video call, thus we can see everything that's going on the other side at the bot. This skype call is also used to send DTMF tones to the bot. The tones received are sent to the DTMF decoder via headphone 3.5mm jack. This decoder decodes the code and microcontroller attached to it controls the motor that ultimately controls the robot. The design is comprised of a battery pack, servo motors, GPS module and an ATmega328 Arduino microcontroller. The microcontroller receives the input from the GPS module in string format through serial communication. This data is then sent through our path finding algorithm and the direction is calculated. The robot runs through the course with minor mishaps. Improvement recommendations include alternate algorithms and additional sensors.

3. SYSTEM DESIGN

3.1 DTMF DECODER

The DTMF Decoder is used to intercept the DTMF tone signals taken from the receiver cell phone and convert the

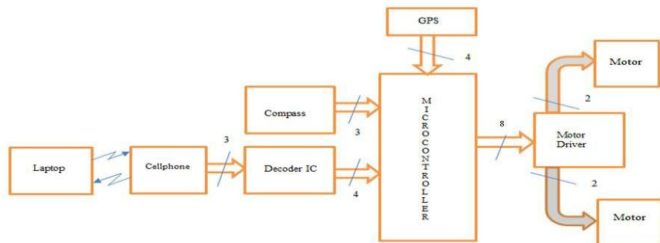

Fig -1: General block diagram

respective tone into a digital output. This output is then connected to the Arduino microcontroller which translates the given decoder input to motor driving output which controls our motors on tone inputs.

3.2 GPS MODULE

GPS module is used to intercept continuous updates about the present GPS location of the robot. Based on this, the destination distance and bearing is calculated which is used by Arduino to move the robot towards the destination.



Fig. 2. GPS module

3.3 DIGITAL COMPASS

The magnetic sensor is used to measure the earth's magnetic field and then to determine the heading angle with respect to the magnetic north. If the heading with respect to the geographic north is required, the

declination angle at the current geographic location should be compensated to the magnetic heading. It is one part of a GPS guided vehicle. Once, the destination bearing is known, we need to know which way we are facing so when we calculate the needed heading we can easily turn to face our waypoint and drive relatively straight there. This is where the compass comes into picture. Only moving forward is not very accurate. When our vehicle is turning, it is not moving forward at all, so we cannot get a good heading reading and we will not know how much to turn. So we are going to use the compass to give us a heading from 0-360 degrees. We will also use a formula that gives us the needed heading between the vehicle's location and the next waypoint location. The formula will give us a heading from 0-360 degrees. So all we have to do is match our heading with the needed heading and drive until we reach the GPS point.

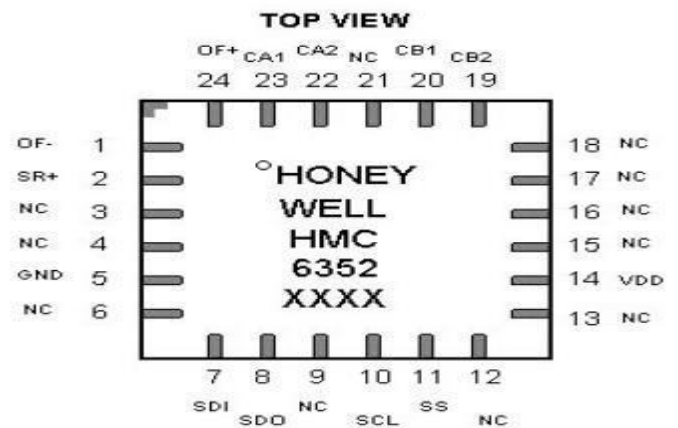

Fig. 3. Digital compass

3.4 ARDUINO MICROCONTROLLER

Arduino is an open-source computer hardware and software company, project and user community that designs and manufactures microcontroller-based kits for building digital devices and interactive objects that can sense and control the physical world. The project is based on a family of microcontroller board designs manufactured primarily by Smart Projects in Italy, and also by several other vendors, using various 8-bit Atmel AVR microcontrollers or 32-bit Atmel ARM processors. These systems provide sets of digital and analog I/O pins that can be interfaced to various expansion boards ("shields") and other circuits. The boards feature serial communications interfaces, including USB on some models, for loading programs from personal computers. For programming the microcontrollers, the Arduino platform provides an integrated development environment (IDE) based on the Processing project, which includes support for C, C++ and Java programming languages.

3.5 GLOBAL POSITIONING SYSTEM

The Global Positioning System (GPS) is a space-based satellite navigation system that provides location and time information in all weather conditions, anywhere on or near the Earth where there is an unobstructed line of sight to four or more GPS satellites. The system provides critical capabilities to military, civil and commercial users around the world. It is maintained by the United States government and is freely accessible to anyone with a GPS receiver. A GPS receiver calculates its position by precisely timing the signals sent by GPS satellites high above the Earth. The receiver uses the messages it receives to determine the transit time of each message and computes the distance to each satellite using the speed of light. Each of these distances and satellites' locations define a sphere. The receiver is on the surface of each of these spheres when the distances and the satellites' locations are correct. These distances and satellites' locations are used to compute the location of the receiver using the navigation equations. This location is then displayed, perhaps with a moving map display or latitude and longitude; elevation information may be included. Many GPS units show derived information such as direction and speed, calculated from position changes. In typical GPS operation, four or more satellites must be visible to obtain an accurate result. Four sphere surfaces typically do not intersect. Because of this we can say with confidence that when we solve the navigation equations to find an intersection, this solution gives us the position of the receiver along with accurate time thereby eliminating the need for a very large, expensive, and power hungry clock. The very accurately computed time is used only for display or not at all in many GPS applications, which use only the location. A number of applications for GPS do make use of this cheap and highly accurate timing. These include time transfer, traffic signal timing, and synchronization of cell phone base stations.

Fig. 4. Digital compass

Although four satellites are required for normal operation, fewer apply in special cases. If one variable is already known, a receiver can determine its position using only three satellites. For example, a ship or aircraft may have known elevation. Some GPS receivers may use additional clues or assumptions such as reusing the last known altitude, dead reckoning, inertial navigation, or including information from the vehicle computer, to give a (possibly degraded) position when fewer than four satellites are visible.

4. NMEA PROTOCOL FOR USING GPS DATA

NEMA 0183 is a combined electrical and data specification for communication between marine electronic devices such as echo sounder, sonar, anemometer, gyrocompass, and autopilot, GPS receivers and many other types of instruments. It has been defined by, and is controlled by, the U.S.-based National Marine Electronics Association. It replaces the earlier NMEA 0180 and NMEA 0182 standards. In marine applications, it is slowly being phased out in favor of the newer NEMA 2000 standard. The electrical standard that is used is EIA - 422, although most hardware with NEMA - 0183 outputs are also able to drive a single EIA - 232 port. Although the standard calls for isolated inputs and outputs, there are various series of hardware that do not adhere to this requirement. The NEMA 0183 standard uses a simple ASCII, serial communications protocol that defines how data are transmitted in a "sentence" from one "talker" to multiple "listeners" at a time. Through the use of intermediate expanders, a talker can have a unidirectional conversation with a nearly unlimited number of listeners, and using multiplexers, multiple sensors can talk to a single computer port. At the application layer, the standard also defines the contents of each sentence (message) type, so that all listeners can parse messages accurately.

5. CONCLUSIONS

The primary purpose of the mobile phone operated robot with DTMF decoder is to know the information in the places where we cannot move. The robot perceives the DTMF tone with the help of the phone stacked in the robot. It provides the advantage of robust control, working range as large as coverage area of service provider. And it also entertains the advantage of coming back to the starting point in case of disconnection from the control station or in any other problematic situations. The future work is to provide the condition monitoring of electronics and implementation of solar based system [11]-[18].

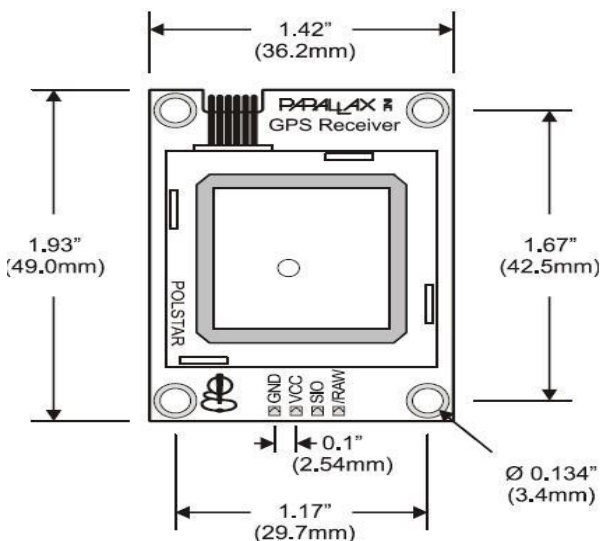

REFERENCES

1. Servo Voltage, FS5109R Data-sheet.
2. [Http://www.openimpulse.com/blog/products-page/product-category/ublox-neo-6m-gps-module/](http://www.openimpulse.com/blog/products-page/product-category/ublox-neo-6m-gps-module/), June 2013 GPS Operating Voltage
3. Arduino: <http://arduino.cc/en/Main/arduinoBoardUno>, June 2013
4. GPS
http://en.wikipedia.org/wiki/Global_Positioning_System, May 2013.
5. Implementation of GPS for Location Tracking , 2011 IEEE Control and System Graduate Research Colloquium, Shah Alam, Malaysia
6. Here are some robotics sites using smartphones:
7. <http://www.cellbots.com/>
8. <http://code.google.com/p/cellbots/>
9. <https://github.com/mleone/broadcast>
10. <http://www.razorconcepts.net/dtmf.html>
11. R Khandebharad, R. B. Dhumale, S. S. Lokhande, "Electrolytic Capacitor Online Failure Detection and Life Prediction Methodology", Int. J. Research in Engg. And Techn., vol.4, Iss. 2, pp.636-641, Feb. 2015.
12. R Khandebharad, R. B. Dhumale, S. S. Lokhande, "Online Failure Prediction of the Aluminum Electrolytic Capacitor", Int. J. Science and Research, vol.4, Iss. 6, pp.2099-2102, June. 2015.
13. R. B. Dhumale, S. D. Lokhande, N. D. Thombare, M.P. Ghatule, "Fault Detection and Diagnosis of High Speed Switching Devices in Power Converter", Int. J. Research in Engg. And Techn., vol.4, Iss. 2, pp.636-641, Feb. 2015.
14. M. R. Ubale, R. B. Dhumale, V. V. Dixit, S. D. Lokhande, " Open Switch Fault Diagnosis Method in Three Phase Inverter", in Proc. National Conference on Latest Trends in Electronics and Telecommunication, Sinhgad College of engineering,Pune, Oct. 2013, pp-28.
15. [M. R Ubale, R. B. Dhumale, S. D. Lokhande, "Method of Open Switch Fault Detection in Three Phase Inverter sing Artificial Neural Network", Int. J. Research in Science and Advance Technology, Vol. 3, Iss. 3, PP 78-82, June 2014.
16. Lalit Patil, R. B. Dhumale, S. D. Lokhande, "Fault Detection and Diagnosis Technique for Power Inverter using Discrete Wavelet Transform", Int. J. Electronics Circuits and systems, Vol. 3, Iss. 2, pp 174-178, June 2014.
17. C. Ugale , R. B. Dhumale , V. V. Dixit, " DC-DC Converter for Solar Energy Harvesting using PID Controller", Int. J. Engineering Applications and Technology, Vol. 1, Iss. 13, pp 132-136, July 2015.
18. Gaurav Kate, Kaustubh Dave, Saprem Kulkarni, "Android Application for S-PARK System", International Journal of Research in engineering and Technology, Vol. 3, Iss. 1, pp 107-110, Oct 2015.