

# Speech Recognition system using PSoC and Android Application

Devarsh Bharambe<sup>1</sup>, S.P.kodgire<sup>2</sup>,

<sup>1</sup> ME Embedded System, Department of E & C Engineering, MIT Maharashtra, Aurangabad (MS), India

<sup>2</sup> Associate Professor, Department of E & C Engineering, MIT Maharashtra, Aurangabad (MS), India

**Abstract**—the fundamental idea of speech is the medium which establishes communication between two people. One of the person initiate speech signal call as sender and other person call as listener will receives that speech and respond according to it. Here in this project sender is the any person and listener is the electronics hardware includes PSoC. The speech recognition must be efficient and convenient with fixed number of vocabulary for human and machine interaction. Now a day's most of people have android phone which runs android OS by the use of this it is convenient to develop android application to run speech recognition at user end. Android application makes it isolated system from hardware part.

**Key Words:** Speech Recognition, PSoC, Programmable System on Chip, Voice operated system.

## 1.INTRODUCTION

The prospect of creating this system is to develop hardware that understands human voice input to that and work upon it. Essentially speech is use to transmit the message. A sequence of various separate symbols that quantify the knowledge in bits uses to represent message. Info transmitted in bits per second (bps). In speaking, the knowledge to be transmitted is encoded within the variety of an unceasingly variable analog wave form that may be transmitted, recorded, manipulated, and ultimately decoded by somebody's auditor. This analog signal is that the speech signal. Once two individuals speak to at least one another, they each acknowledge the words Controller based mostly system, on the opposite hand, are solely capable of the primary thing: they'll acknowledge individual words and phrases; however they don't very perceive speech within the same method as humans do. That Hardware acknowledges the command and computer code tells the pc what to try once that command is recognized. Speech recognition systems have another constraint regarding the types of speech they'll acknowledge. They're three forms of speech: isolated, connected and continuous. This speech recognition system will simply handle words that are spoken singly. This can be the foremost common speech recognition systems out there these days. The user should pause between every word and command spoken. The speech recognition circuit is about up to spot isolated words of .96 second lengths. Isolated word recognizers typically need every auditory

communication to possess quiet (lack of associate audio signal) on each side of the sample window. It doesn't suggest that it accepts single words, however will need one auditory communication at a time. Often, these systems have "Listen/Not-Listen" states, wherever they need the speaker to attend between utterances (usually doing process throughout the pauses). Isolated auditory communication can be a more robust name for this category . Properly connected utterances are kind of like isolated words; however permit separate utterances to be run-together with a smallest pause between them.

Continuous recognition is that the next step. Recognizers with continuous speech capabilities are a number of the foremost tough to make as a result of they have to utilize special ways to work out auditory communication boundaries. Speech recognition is that the method of finding a interpretation of a spoken utterance; usually, this suggests finding the sequence of words that were spoken. This involves pre-processing the acoustic signals to parameterize it in an exceedingly additional usable and helpful type. The input should be matched against a hold on pattern then makes a choice of accretive or rejecting a match. No Two utterances of constant word or sentence are possible to convey rise to constant digital signal. This obvious purpose not solely underlies the issue in speech recognition however additionally implies that we have a tendency to be ready to extract over simply a sequence of words from the signal. There are a couple of issues in speech recognition that haven't however been discovered. But there are varieties of issues that are known over the past few decades most of that still stay unresolved. the various styles of issues we have a tendency to are attending to face in our project are enumerated below:

### 1.1. Determining word boundaries

Speech is sometimes continuous in nature and word boundaries aren't clearly outlined. one in all the common errors in continuous speech recognition is that the missing out of a minuscule gap between words. This happens once the speaker is speaking at a high speed.

### 1.2. Varying Accents

Individuals from totally different elements of the planet pronounce words otherwise. This results in errors in ASR. But this can be one drawback that's not restricted to ASR however that plagues human listeners too.

### 1.3. Massive Vocabularies

Once the quantity of words within the info is massive, similar sounding words tend to cause a high quantity of error i.e.

there's an honest likelihood that one word is recognized because the alternative.

**1.4. Dynamic space Acoustics**

Noise could be a major think about ASR. In truth it's in abuzz conditions or in dynamic space acoustic that the constraints of gift day ASR engines become outstanding.

**1.5. Temporal Variance**

Totally different speakers speak at different speeds. gift day ASR engines simply cannot adapt to it.

contain one among the three PSoCs – PsoC1, PSoC3 and PSoC5. The process performance, practicality, internal reminiscences and configurability of the PSoC will increase from PSoC1 through PSoC5.

**2. DESIGN OF SYSTEM**

In this System input voice commands are taken from android application that compare with desired command and causes interrupt, holding the controller understand a recognized word had been spoken. The advantage of mistreatment associate interrupt is that polling the circuit's recognition line often would not be necessary, further reducing any overhead. Another advantage to this android primarily based application is its programmability. You'll be able to program and train the appliance to recognize the distinctive words you would like recognized. The appliance is often simply interfaced to the controller. To regulate and command an appliance by talking to it, can make it easier, whereas increasing the efficiency and effectiveness of operating therewith device. Diagram is shown below.

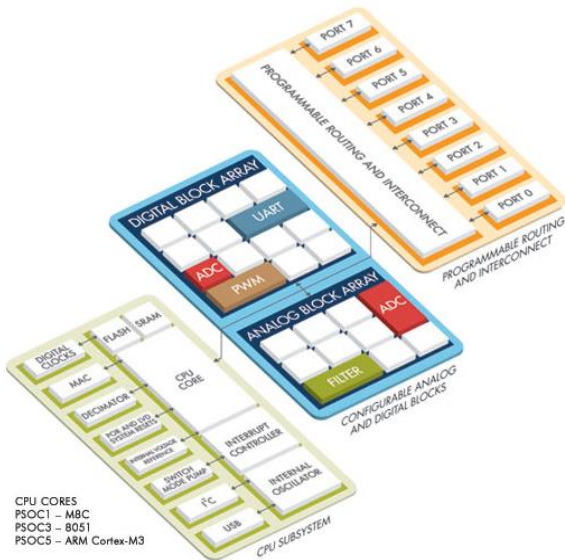

**Fig 1:** Architecture of PSoC

Programmable System on Chip (PSoC) has and is being utilized during a variety of applications. They're cost effective as a result of that they need restricted storage and process power. Programmable System on Chip (PSoC) has been designed and enforced by Cypress semiconductors.

**Table -1:** Comparison of PSoCs.

FEATURES	PSoC1	PSoC3	PSoC5
<b>CPU</b>	8-bit M8C core	8-bit 8051	32-bit ARM Cortex
<b>Flash</b>	4 to 32kB	8 to 64kB	32 to 256kB
<b>Interface</b>	I <sup>2</sup> C, SPI, UART, FS, USB 2.0	I <sup>2</sup> C, SPI, UART, LIN, FS, USB 2.0, I <sup>2</sup> S, CAN	I <sup>2</sup> C, SPI, UART, LIN, FS, USB 2.0, I <sup>2</sup> S, CAN
<b>ADCs</b>	1 delta-sigma	1 Delta-Sigma	1 Delta-Sigma, 2SARs
<b>DACs</b>	2(6 bit)	4(8 bit)	4(8 bit)
<b>I/Os</b>	64	72	72

Every PSoC contains a microcontroller, programmable analog blocks like ADC, DAC, I/O drivers and digital blocks like Universal Digital Blocks (UDBs), CAN, I2C, PWM in a single chip. Embedded Development kits from Cypress

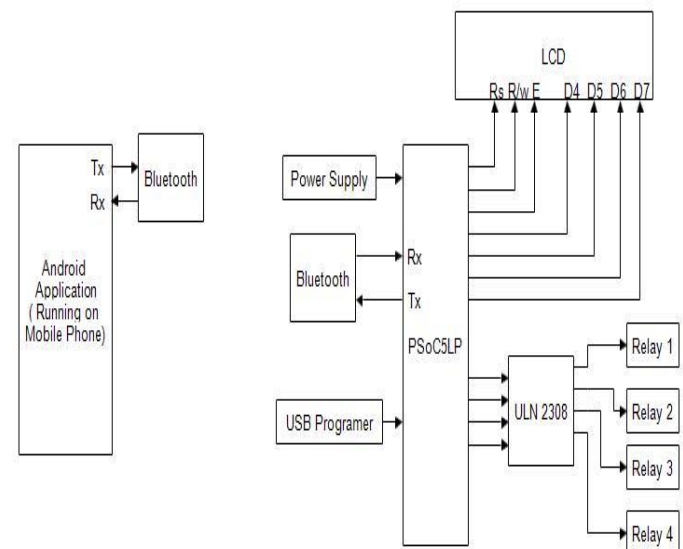

**Fig 2:** Block Diagram of System.

Here the communication is done between android application and hardware using Bluetooth interface. Speech recognition application will receives voice commands from user and send text over Bluetooth and produces interrupt. At controller side, text will compare with set text command that will allow operating final control element. The advantage of this is that controller no longer to make pooling rx pin, now controller will occasionally need to poll that pin this will reduces any overhead.

**2.1. Android Application:**

Android is a much acquainted word within the world these days. Ample devices are running the Google android OS and millions are being developed daily. Google has created the

android development platform hospitable everybody round the world, so there are many developers. Though some developers simply concentrate on building the apps or games for the android devices, there are various prospects also.

App inventor for android is an application originally provided by Google, and currently maintained by the Massachusetts Institute of Technology (MIT). It permits anyone aware of computer programming to form software applications for the android operating system (OS). It uses a graphical interface, very similar to Scratch and therefore the Star logo TNG user interface that enables users to drag-and-drop visual objects to form an application which will run on the android system that runs on several mobile devices. The primary phase of application design goes through App inventor Designer. Designer is accessible through the web page and every one the ingredients for the app are accessible on the left side of the window. The ingredients embrace components like a screen for the app, buttons for tapping, text boxes, images, labels, animations and many more. The right side of the designer permits users to look at the screen and components added to the screen. In addition, the properties section of the window permits users to change the properties of component.

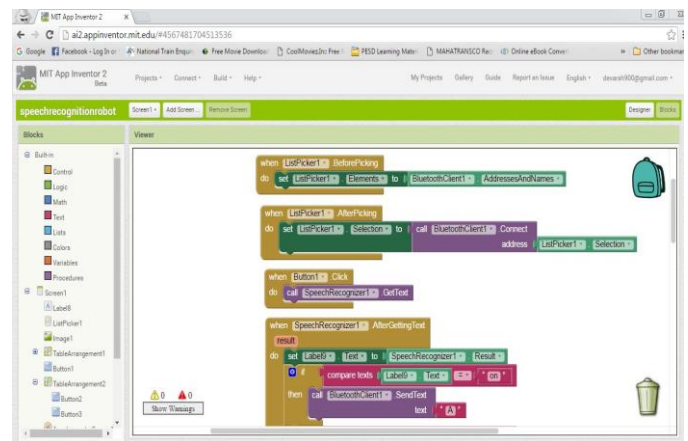

**Fig 4: Block Coding Window of App inventor.**

**2.2. Programmable System on Chip(PSoC5LP):**

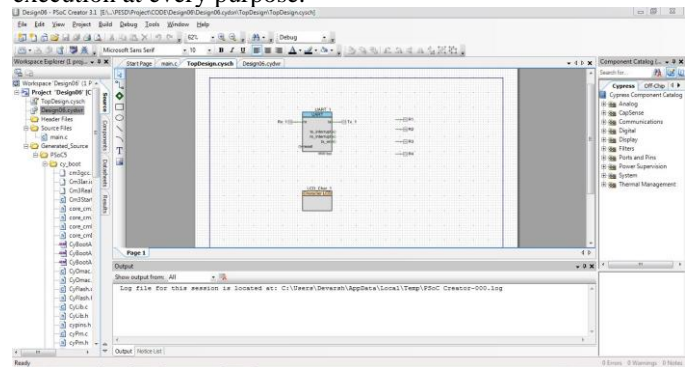

**Fig 5: PSoc 5LP (CY8CKIT-059).**

For the development and implementation of systems mistreatment PSoc5, PSoc Creator software package is employed. PSoc Creator is a visual development tool and Integrated Development environment for PSoc. It’s an expensive library of prebuilt components and a schematic design entry tool. It combines C based development flow with an automatically generated Application programmable interface (API). API reduces the errors in code and ensures correct interfacing with the peripheral that allows the software development to be quicker, easier and fewer at risk of errors. The PSoc Creator additionally has powerful, modern debugger that is made within the IDE. It is used to show the values after execution at every purpose.



**Fig 3: GUI of App.**



**Fig 6: PSoc Creator Window.**

**2.3. Bluetooth Module:**

HC serial Bluetooth product contains Bluetooth serial interface module and Bluetooth adapter. Bluetooth serial module is employed for changing port to Bluetooth. These modules have two modes: master and slaver device.

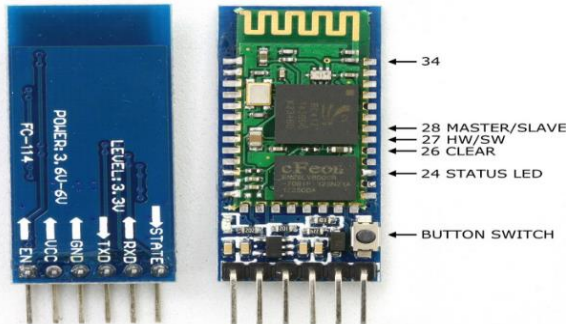

Fig 7: Bluetooth Module.

**2.4. Relay module:**

This relay module contains 4 relay for operating final control element. Each relay is capable of operating on 50/60 Hz frequency. It supports different AC and DC current-voltage ratings as follows:

- o 5A 250V AC
- o 10A 120V AC
- o 12A 120V DC
- o 10A 24V DC

**2.5. Flow Chart**

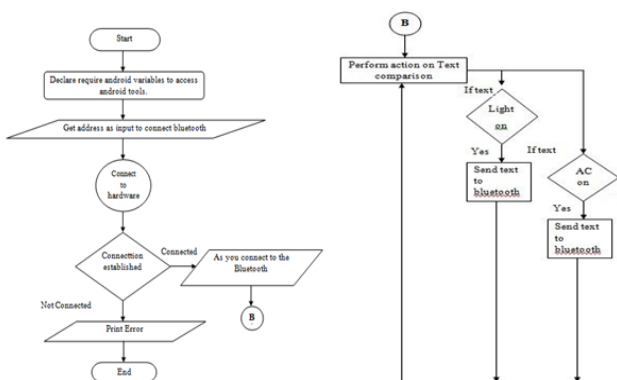

Fig 8: Flow chart for Android application.

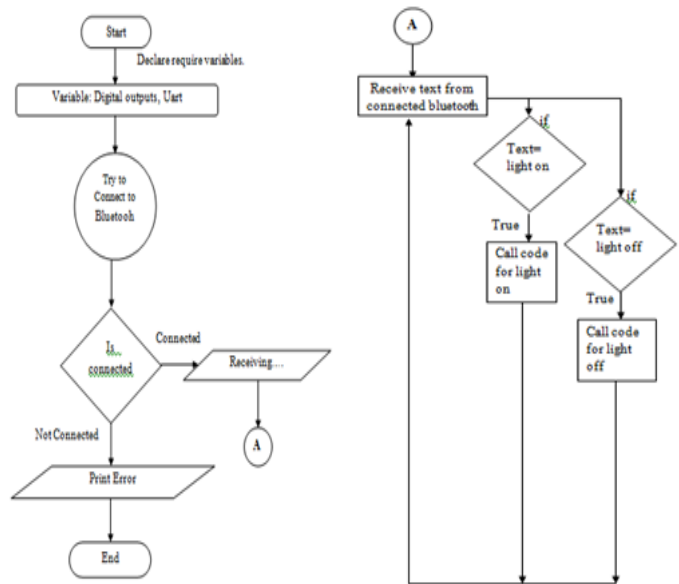

Fig 9: Flow chart for PSoc.

**3. RESULT**

**3.1. Performance Result:**

Table -2: Result of Recognition Of Commands.

Commands	Number of testing	Correct recognition	Incorrect recognition
ON	10	10	0
OFF	10	10	0
Lights On	10	8	2
Lights Off	10	8	2
AC On	10	9	1
AC Off	10	8	2
Open	10	10	0
Close	10	10	0

Table -2: Command Recognition Probabilities.

Commands	Recognition Probabilities
ON	100%
OFF	100%

Lights On	80%
Lights Off	80%
AC On	90%
AC Off	80%
Open	100%
Close	100%

4.	PSoC + BT +LCD + 1relay	92.0 mA	11.95V
5.	PSoC + BT +LCD + 2relay	102.0 mA	11.60V
6.	PSoC + LCD + All relay	125.00 mA	11.30 V
7.	All Component with all relay on	156.00 mA	10.99 V

Formula for power calculation is as follow.

$$P = I \times V$$

Condition 3 and 7 gives us relevant idea about power consumption of hardware. Lets we calculate power for these condition For condition 3,current I is 80.0 mA and voltage is 11.88 V there for power consumption is 950.4 mW/h. Similarly, for condition 7 we calculated power consumption 1.714 W/h.

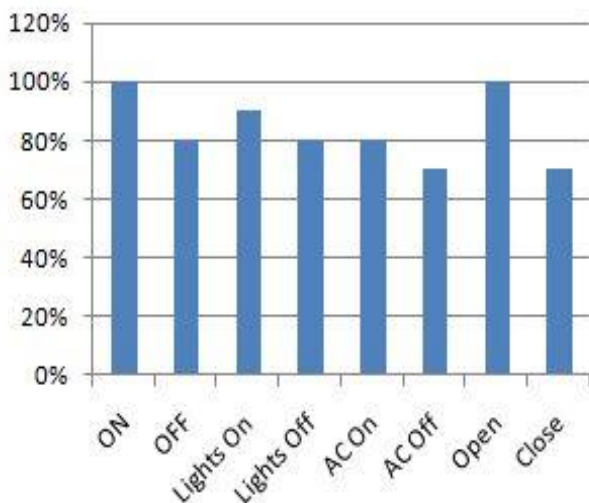

Chart -1: Name of the chart

### 3.2.Power Consumption:

It is also important to know the power consumption of project hardware. Here we have taken different condition depend upon how many components are connected in circuit.

Table -2: Power Consumption

Sr No.	Number of component	Current ( I )	Voltage ( V )
1.	PSoC and power supply component	22.06 mA	12.67 V
2.	PSoC and LCD	37.11 mA	12.42 V
3.	All Component but relay off	80.0 mA	11.88V



Fig 10: Project implementation.

### 4. CONCLUSION

In this project we tend to speech recognition is completed and appliances are controlled using speech commands are given from isolated distant from user. These input

commands are given as input to the PSoC 5 kit wherever the PSoC is programmed to provide the required result. Use of android application reduces any overhead on for controller.

## REFERENCES

- [1] V. Naresh, B. Venkataramani, Abhishek Karan and J. Manikandan, "PSoC based isolated speech recognition system" International conference on Communication and Signal Processing, April 3-5, 2013
- [2] Santosh K.Gaikwad, Bharti W.Gawali, Pravin Yannawar, "A Review on Speech Recognition Technique" International Journal of Computer Applications Volume 10- No.3, November 2010
- [3] M.A.Anusuya, S.K.Katti "Speech Recognition by Machine: A Review", International Journal of Computer Science and Information Security, Vol. 6, No. 3, 2009
- [4] Dr. Sunita Rana "The process of speech recognition, perception, speech signals and speech production in human beings", International Journal of Advanced Research in Computer Engineering & Technology Volume 1, Issue 9, November 2012
- [5] Nidhi Desai, Prof.Kinnal Dhameliya, Prof.Vijayendra Desai "Feature Extraction and Classification Techniques for Speech Recognition: A Review", International Journal of Emerging Technology and Advanced Engineering, Volume 3, Issue 12, December 2013
- [6] Ms. Vrinda ,Mr. Chander Shekhar "Speech recognition system for English language", International Journal of Advanced Research in Computer and Communication Engineering Vol. 2, Issue 1, January 2013
- [7] Sonali N. Malshikare, Prof. V. M. Sardar "Speech Enhancement through Elimination of Impulsive Disturbance Using Log MMSE Filtering", International Journal of Engineering Research and General Science Volume 3, Issue 1, January-February, 2015
- [8] Lindasalwa Muda, Mumtaj Begam and I. Elamvazuthi "Voice Recognition Algorithms using Mel Frequency Cepstral Coefficient (MFCC) and Dynamic Time Warping (DTW) Techniques", JOURNAL OF COMPUTING, VOLUME 2, ISSUE 3, MARCH 2010
- [9] Shipra J. Arora ,Rishi Pal Singh "Automatic Speech Recognition: A Review", International Journal of Computer Applications (0975 - 8887) Volume 60- No.9, December 2012
- [10] Sadaoki Furui "50 Years of Progress in Speech and Speaker Recognition Research" ECTI transactions on computer and information technology vol.1, no.2 november 2005
- [11] James M. Kates, Senior Member, IEEE "A Time-Domain Digital Cochlear Model", IEEE TRANSACTIONS ON SIGNAL PROCESSING, VOL 39. NO. 12, DECEMBER 1991
- [12] By L. R. RABINER and M. R. SAMBUR "An Algorithm for Determining the Endpoints of Isolated Utterances"
- [13] Sven E. Krüger, Martin Schaffner, Marcel Katz, Edin Anđelić, Andreas Wendemuth "Speech Recognition with Support Vector Machines in a Hybrid System" IESK, Cognitive Systems, Otto-von-Guericke-University Magdeburg, PF 4120, 39016 Magdeburg, Germany
- [14] Nobuo Hataoka ,Yasunari Obuchi, Teruko Mitamura, Eric Nyberg "Robust Speech Dialog Interface for Car Telematics Service"
- [15] Ashutosh Saxena and Abhishek Singh "A Microprocessor based Speech Recognizer for Isolated Hindi Digits"
- [16] <http://www.cypress.com/products/programmable-system-chip-psoc>
- [17] [http://artsites.ucsc.edu/EMS/music/tech\\_background/TE-20/teces\\_20.html#1](http://artsites.ucsc.edu/EMS/music/tech_background/TE-20/teces_20.html#1).
- [18] [www.Howstuffworks.com](http://www.Howstuffworks.com) for understanding microphone concepts and other related concepts.
- [19] Lawrence Rabiner, Biing-Hwang Juang "Fundamentals of Speech"
- [20] Ashutosh Saxena and Abhishek Singh "A Microprocessor based Speech Recognizer for Isolated Hindi Digits"
- [21] [www.developer.android.com/training/basics/firstapp](http://www.developer.android.com/training/basics/firstapp)