

# Implementation of Efficient Energy Consumption on Photovoltaic Cell Using MATLAB Programming

Ankit Parganiha<sup>1</sup>, Prof. Rajiv Pathak<sup>2</sup>

<sup>1</sup>M.Tech. Student of Instrumentation & Control Engineering, Bhilai Institute of Technology, Durg, C.G., India  
ankitparganiha@gmail.com

<sup>2</sup>Professor of Information Technology, Bhilai Institute of Technology, Durg, Chhattisgarh – 491001, India  
pathakbaba.buxar@gmail.com

\*\*\*

**Abstract** - Solar power generation has been used as renewable energy and the main objective of this project to design such a system by which we can generate the maximum power. In this project we basically focused on the closed loop system by which we can get the maximum power without the human interface. PV cell basically works according to the intensity & irradiance of sun light so PV cell voltage and current always fluctuating according to the intensity of sun rays.

The major issue in now a day is the scarcity of energy because, the energy resources are very less and the corresponding energy production is not appropriate to consume requirement. For a well develop city surplus electricity is very important. And we know that all our natural resource is vanishing day by day as they are non renewable source of energy. Scientist are very much concerned about this thing as they know it pollutes our environment also solar energy is one of the free source of energy. Now there are lots of research are going in these sector How to utilize maximum current by these use of photovoltaic cell.

In these proposed system, by the use of SEPIC and MPPT we are designing a closed loop system which will give us maximum power by automatic regulating the voltage.

**Key Words:** MPPT, SEPIC, PV CELL

## 1. INTRODUCTION

The production of energy is a major task for the coming years & in the rural area it is not possible to provide electricity from the power plant. So, government is taking many needful steps to provide electricity in these areas and the best way to provide electricity in those places is to implement solar panel. But the major issue in implementing these panels is they are very expensive and the generation of electricity is very less. Now a day's lots of research are going in this field "How to maximize the generation of electricity with the help of PV cell".

To meet the energy needs of today's society, it is necessary to find solutions adapted and diversified. Currently, there are mainly two ways to act. The first is to reduce the

consumption of energy receptors and increase productivity power plants by improve their efficiency. A second method is to develop new energy sources. Research is courses in the field of nuclear fusion that possibly could be solution energy of the future, but the future of this industry let alone its advent are not insured. For now, we have inexhaustible resources in renewable energy we are able to operate more easily and cleanly. Extraction techniques the power of these resources require more extensive research and development for reliability, lower costs (manufacturing, use and recycling) and increase energy efficiency.

The huge usage of the fossil fuels, such as the oil, the coal and the gas, result in serious greenhouse effect and pollute the atmosphere, which has great impact on the world. Meanwhile, there is a massive contradiction between the fossil fuels supply and the global energy demand, which leads to a high oil price in the international market recently. The energy shortage and the atmosphere pollution have been the major limitations for the human development. How to find renewable energy is becoming more and more exigent.

Photovoltaic (PV) sources plays an important role in the world's energy portfolio and in future it will become one of the biggest contributor to the electricity generation among all renewable energy, candidates by 2040 it will become truly a clean, emission-free renewable electrical generation technology with high reliability. The task of a maximum power point tracker (MPPT) in a photovoltaic (PV) energy conversion system is to continuously track the maximum power with the help of current and voltage so that it draws maximum power from the solar array irrespective of weather or load conditions.

### 1.1 PV CELL MODULE & ARRAY

The building block of PV array is the solar cell which is basically an p-n junction semiconductor that directly converts light energy into electricity .PV systems involve large fluctuations of the frequency, power and voltage in the grid. PV cells are grouped in large units called PV panels which are further interconnected in a parallel-series configuration to form PV arrays to simulate the array, cell model parameters

are properly multiplied by number of cells. In the below figure the configuration of series & parallel configuration is shown .In figure (a) parallel connection of PV cells is shown in that current always increases and the voltage remains constant when PV cell is connected parallel and when the PV cells are connected in series the voltage increases and the current remains constant.

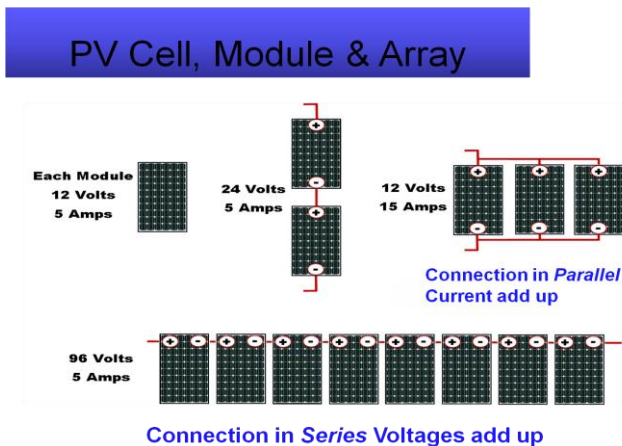

Fig -1: PV Cell parallel and series connection.

### 1.2 MPPT (MAXIMUM POWERPOINT TRACKING)

MPPT maximum power point tracker is an electronic DC to DC convertor that optimizes the match between the solar array(PV panels) and the battery bank or utility grid .In simple words MPPT basically convert a higher voltage DC output from solar panel.

MPPT is similar to PWM but the main reason to select MPPT is having lots of advantage as compare to PWM. Research has been done by using both the convertors and it is found that the output generated by MPPT is always high. Below some comparison that shows how MPPT and PWM works.

PWM	MPPT
( Pulse Width Modulation)	(Maximum Power Point Tracking)
■ Pulses direct connection from pv cell to battery	■ Converts voltage input to battery voltage
■ Voltage pulled down to battery voltage	■ Increase current when voltage drops

As we know power conversion efficiency of solar module is very low. To increase efficiency of solar module proper impedance matching require to increase efficiency of solar module .So different type of MPPT method developed by researcher in recent year. Every method has its own kind of advantage.

MPPT with one output and a charge voltage' is 'protected' output to power consumers, which automatically cuts the current when the battery has a voltage too low. Is almost never used on a boat, but widely used in solar installations on land.

MPPT Techniques Over the past decades many methods to find the MPPT have been developed. These techniques differ in many aspects such as required sensors, complexity, cost, range of effectiveness, convergence speed, correct tracking when irradiation and/or temperature change, hardware needed for the implementation or popularity, among others. Some of the most popular MPPT techniques are:

1. Perturb and observe (hill climbing method)
2. Incremental Conductance method
3. Fractional short circuit current
4. Fractional open circuit voltage
5. Fuzzy logic
6. Neural networks
7. Ripple Correlation Control
8. Current Sweep
9. DC-link capacitor droop control
10. Load current or load voltage maximization
11. dP/dV or dP/dI Feedback control

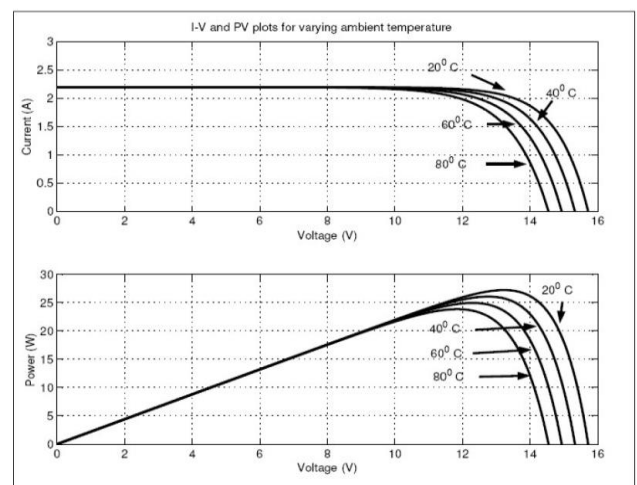

Fig -2: I-V and P-V curve at different irradiance

Among several techniques mentioned, the Perturb and Observe method and the Incremental Conductance algorithms are the most commonly applied algorithms. Other techniques based on different principles include fuzzy logic control, neural network, fractional open Circuit voltage or short circuit current, current sweep, etc. Most of these methods yield a local maximum and some, like the fractional open circuit voltage or short circuit current, current sweep, etc. Most of these methods yield a local maximum and some, like the fractional open circuit voltage or short circuit current, give an approximated MPP, rather than an exact

output. In normal conditions the V-P curve has only one maximum. However, if the PV array is partially shaded, there are multiple maxima in these curves. Both P&O and Incremental Conductance algorithms are based on the “hill-climbing” principle, which consists of moving the operation point of the PV array in the direction in which the power increases. Hill-climbing techniques are the most popular MPPT methods due to their ease of implementation and good performance when the irradiation is constant. The advantages of both methods are simplicity and requirement of low computational power. The drawbacks are: oscillations occur around the MPP and they get lost and track the MPP in the wrong direction during rapidly changing atmospheric conditions. Perturb and Observe in the P&O method only one voltage sensor is used to sense the PV array voltage and hence the cost of implementation is less. The algorithm involves a perturbation on the duty cycle of the power converter and a perturbation in the operating voltage of the DC-link between the PV array and the power converter. Perturbing the duty cycle of the power converter implies modifying the voltage of the DC-link. 2.10 Maximum Power Point Tracking between the PV array and the power converter. In this method, the sign of the last perturbation and the sign of the last increment in the power are used to decide the next perturbation as can be seen on the left of the MPP incrementing the voltage increases the power whereas on the right decrementing the voltage decreases the power. If there is an increment in the power, the perturbation should be kept in the same direction and if the power decreases, then the next perturbation should be in the opposite direction. Based on these facts, the algorithm is implemented as show in the flowchart in and the process is repeated until the MPP is reached. The operating point oscillates around the MPP.

## 2. SEPIC (SINGLE ENDED PRIMARY INDUCTANCE CONVERTOR)

In a single ended primary inductance converter (SEPIC) is basically a DC to DC convertor that has an output magnitude that is either greater than or less then the input voltage magnitude design ,the output voltage can be higher or lower than the output voltage .The SEPIC convertor uses two inductor L1 and L2. The inductors can be wound on the same core since the same voltages are applied to them throughout the switching cycle whereas, the SEPIC convertor solve this problem.

SEPIC is similar to buck boost type of controller but the main difference is that buck boost controller is having inverting property that is it takes positive voltage and gives inverted result. SEPIC convertor maintains a fixed output voltage regardless of whether the input voltage is above, equal or below the output voltage. The buck boost feature of the SEPIC widens the applicable PV voltage and thus increase the adopted PV module flexibility.

In [1] SEPIC convertor using low cost control circuit has been designed for PV system. The convertor maintains the constant output voltage even though the output voltage from PV system changes. The simulation of SEPIC convertor based on PV system is done using MATLAB simulink which uses PI controller. A prototype 20W SEPIC convertor is constructed with two number of 12V solar panel and the results are also verified experimentally.

### PROPOSED BLOCK DIAGRAM OF PV

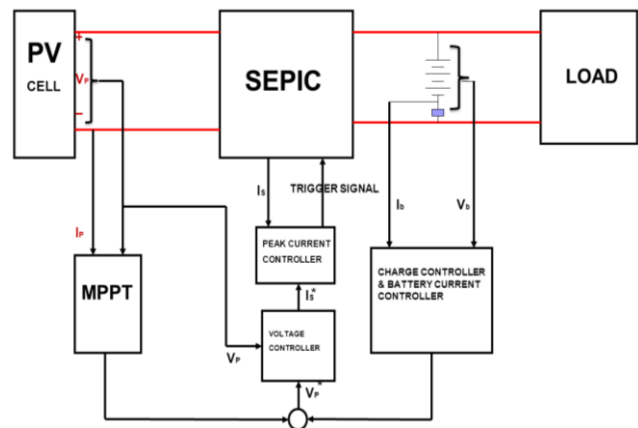

Fig.-3: Block diagram of Proposed PV Cell charging system

### 3. PROPOSED SYSTEM CONFIGURATION

This circuit configuration of the proposed PV charger shown in the figure, the SEPIC convertor employs the peak current-mode control with an outer PV voltage regulating loop, where the voltage command ( $V_p^*$ ) is generated by combining the MPPT control loop and the battery charging loop. The combination of MPPT and charging control is for instantaneously balancing the system power to charge the battery with three stages, namely, constant-current, constant-voltage, and floating charge stages.

The charger system implemented with the single-ended primary inductance converter (SEPIC). Although the boost convertor usually has higher efficiency than the SEPIC, however, it is only applicable for cases where the battery voltage is higher than the PV module voltage.

The buck–boost feature of the SEPIC widens the applicable PV voltage and thus increases the adopted PV module flexibility. Although the SEPIC is not the best from the views of efficiency and cost, it still has the merits of non-inverting polarity, easy-to drive switch, and low input-current pulsating for high-precise MPPT that makes its integral characteristics suitable for the low-power PV charger system.

This paper will investigate the SEPIC with the PV module input and the peak-current-mode control that was seldom presented in previous studies. The small-signal model of such

a SEPIC will be derived, and upon which, the PV voltage controller and the MPPT controller will be designed.

### 3.1. PV CHARGER SYSTEM IMPLEMENTED WITH MATLAB SIMULATION

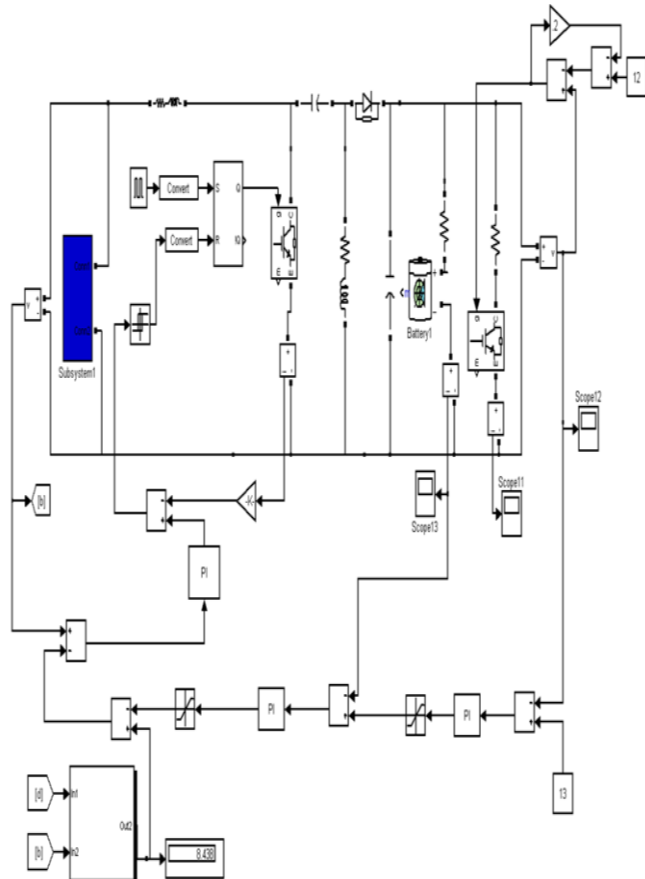

Fig-4: Final design of MATLAB Simulink model

### 4. RESULTS AND DISCUSSIONS

In wave forms shows the MPPT output voltage  $V_{MPPT}$  is the input voltage of the MPPT Controller and with the help of Perturb and Observe (hill climbing method) the maximum power is tracked. Output voltage of SEPIC converter  $V_{out}$ , battery current  $I_b$  and load current  $I_L$ . when load power is larger and PV cell is not capable to give complete power to load, in this case PV cell give its maximum possible power with the support of MPPT and reaming power will be provided by battery, thus in this mode of operation battery is discharging.

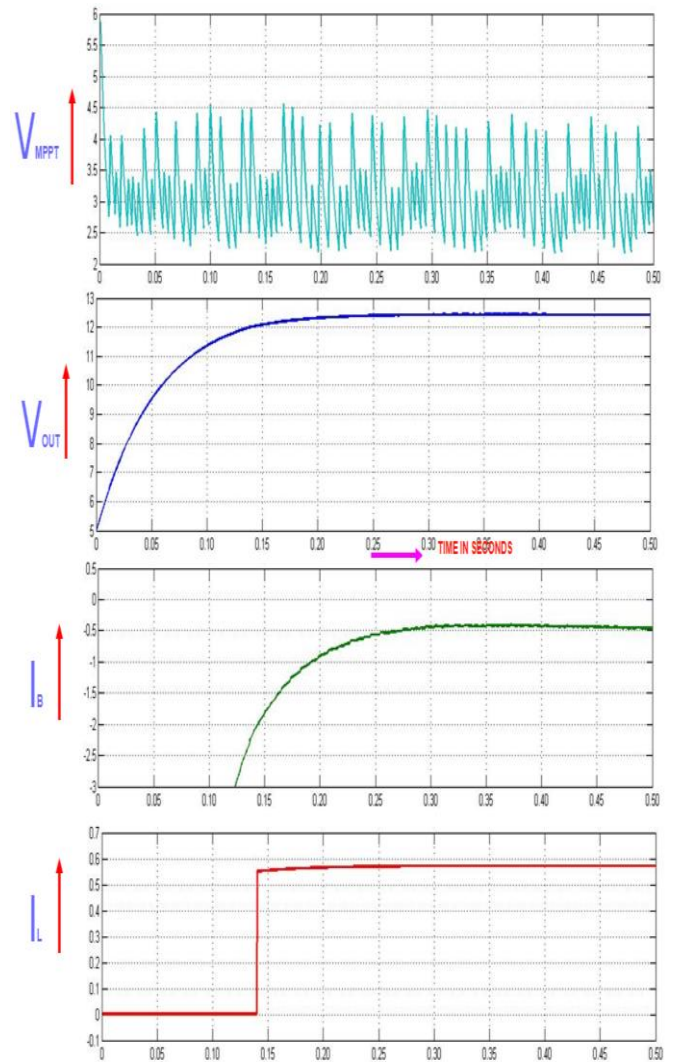

Fig -5: Waveforms for demonstrating the power balance feature

### 5. CONCLUSIONS

This paper presents a PV charger implemented with the SEPIC converter. With the use of MPPT and SEPIC converter the system gives better output so the system has been proved to be effective in the MPPT and power balance control. The proposed modeling method of the converter with the PV module input and peak current- mode control, the adaptive MPPT control method, as well as the power balance control method can also be applied to the charger with other types of converter. The MPPT controller was implemented with the MATLAB simulation, and it will be changed with the voltage controller and PWM to make the system more practical in the future.

**REFERENCES**

- [1] JATIT & LLS, "Design and implementation of low cost SEPIC photovoltaic system for constant voltage", S. Venkatanarayanan, M. Saravanan, ISSN 1992-8645 Volume 63 No 3, Issue 31, May 2014.
- [2] Sree Manju B, Ramaprabha R, Mathur B.L, "Design and Modeling of Stand alone Solar Photovoltaic Charging system" International Journal of Computer Application (0975-8887), Vol. 18, Issue 2, March 2011.
- [3] Hicham Fakhm, Di Lu, Bruno Francosis IEEE, "Power control design of a battery charger in a hybrid active PV generator for load" IEEE transaction on Industrial electronics, Vol 58, ISS.1, PP.85-94, JANUARY 2011, TIE-09-1307.
- [4] R. Sridhar, Dr. Jeevanathan, N. Thamizh Selvan, Saikat Banerjee "Modeling of PV array and performance enhancement by MPPT Algorithm", International journal of computer application (0975-8887) Volume 7-No 5, September 2010.
- [5] Hairul Nissah Zainudin, Saad Mekhilef, "Comparison Study of Maximum Power Point Tracker Techniques for PV Systems", Proceedings of the 14th International Middle East Power Systems Conference (MEPCON'10), Cairo University, Egypt, December 19-21, 2010, Paper ID 278.
- [6] Shiba Arora<sup>1</sup>, Pankaj sharma<sup>2</sup>, "Modeling & Simulation of Photovoltaic System to Optimize the Power Output Using DC-DC Converter" Vol. 3, Issue 7, July 2014.
- [7] Huan-Liang Tsai, Ci-Siang Tu, and Yi-Jie-Su, Member, IAENG "Development of Generalized Photovoltaic Model Using MATLAB/SIMULINK", Proceedings of the World Congress on Engineering and Computer Science 2008 WCECS 2008, October 22 - 24, 2008, San Francisco, USA.
- [8] Farhan A. Salem<sup>1,2</sup>, B. Saleh<sup>1,3</sup>, "Modeling, Simulation and Control Studies on Photovoltaic-Converter System for Mechatronics Design of Solar Electric Application", IJ. Intelligent Systems and Applications, 2015, 01, 9-30 Published Online December 2014 in MECS (<http://www.mecs-press.org/>) DOI:10.5815/ijisa.2015.01.02.
- [9] Athimulam Kalirasu<sup>1</sup>, Subharensu Sekar Dash<sup>2</sup>, "Simulation of Closed Loop Controlled Boost Converter for Solar Installation", SERBIAN JOURNAL OF ELECTRICAL ENGINEERING Vol. 7, No. 1, May 2010, 121-130.
- [10] Nevzat Onat, "Recent Developments in Maximum Power Point Tracking Technologies for Photovoltaic Systems", Hindawi Publishing Corporation International Journal of Photoenergy Volume 2010, Article ID 245316, 11 pages.
- [11] Marcelo Gradella Villalva, Jonas Rafael Gazoli, and Ernesto Ruppert Filho, "Comprehensive Approach to Modeling and Simulation of Photovoltaic Arrays", IEEE TRANSACTIONS ON POWER ELECTRONICS, VOL. 24, NO. 5, MAY 2009.
- [12] M. G. Villalva, J. R. Gazoli, E. Ruppert F, "Modeling and circuit-based simulation of photovoltaic arrays", Brazilian Journal of Power Electronics, 2009 vol. 14, no. 1, pp. 35--45, ISSN 1414-8862.
- [13] Mummadi Veerachary, "Control of TI-SEPIC Converter for Optimal Utilization of PV Power", IICPE, 2010 New Delhi.
- [14] R. Sridhar, Dr. Jeevanathan, N. Thamizh Selvan, Saikat Banerjee, "Modeling of PV Array and Performance Enhancement by MPPT Algorithm", International Journal of Computer Applications (0975 - 8887) Volume 7- No.5, September 2010.
- [15] Hairul Nissah Zainudin, Saad Mekhilef, "Comparison Study of Maximum Power Point Tracker Techniques for PV Systems", Cairo University, Egypt, December 19-21, 2010, Paper ID 278.
- [16] Katherine A. Kim and Philip T. Krein, "Photovoltaic Converter Module Configurations for Maximum Power Point Operation", University of Illinois Urbana-Champaign Urbana, IL 61801 USA.
- [17] Huan-Liang Tsai, Ci-Siang Tu, and Yi-Jie Su, "Development of Generalized Photovoltaic Model Using MATLAB/SIMULINK", Proceedings of the World Congress on Engineering and Computer Science 2008 WCECS 2008, October 22 - 24, 2008, San Francisco, USA.
- [18] M. Berrera, A. Dolara, R. Faranda and S. Leva, "Experimental test of seven widely-adopted MPPT algorithms", 2009 IEEE Bucharest Power Tech Conference, June 28th - July 2nd, Bucharest, Romania.
- [19] P. S. Revankar, W. Z. Gandhare and A. G. Thosar Government College of Engineering, Aurangabad, "Maximum Power Point Tracking for PV Systems Using MATLAB/SIMULINK", 2010 Second International Conference on Machine Learning and Computing.
- [20] Ramos Hernanz, JA., Campayo Martín, JJ. Zamora Belver, I., Larrañaga Lesaka, J., Zulueta Guerrero, E. Puelles Pérez, E., "Modeling of Photovoltaic Module", International Conference on Renewable Energies and Power Quality (ICREPQ'10) Granada (Spain), 23th to 25th March, 2010.