

# LATERAL TORSIONAL BUCKLING OF CASTELLATED I BEAM WITH CORRUGATED WEB

Krishnarani.K.K<sup>1</sup>, Nikhil Mohanan<sup>2</sup>

<sup>1</sup>PG Student, Department of Civil Engineering, Vedavyasa Institute of Technology, Kerala, India

<sup>2</sup>Research Engineer, FEM CFD Research and Development, Angamaly, Kerala, India

\*\*\*

**Abstract** - The paper work dealt with a parametric study of castellated I beam with corrugated web at varying depth and opening size. One aim of this research is to study the developed shell finite element models to investigate and understand the lateral torsional buckling behavioral characteristics of simply supported beam. By utilizing the non linear analysis and FE models to characterize the load- deflection and moment-rotation responses of castellated I beam in lateral torsional buckling state with the help of finite element software ANSYS. Castellated steel beam with corrugated web are lightweight sections with high strength as compared to simply corrugated web. The use of castellated I beam suppress the cost of material by applying more efficient cross sectional shapes made from standard sinusoidal profile in combination. That also causes smooth stress distribution.

**Key Words:** Lateral-torsional buckling, castellated beam, trapezoidally corrugated web, non linear analysis, ANSYS, parametric study...

## 1. INTRODUCTION

In this thesis, the study of lateral torsional buckling of sinusoidal shape castellated I beam with trapezoidally corrugated web will be investigated. Castellated steel beam with corrugated web are lightweight sections with high strength. While, lateral torsional buckling is one of the failure modes at the section of castellated slender beam. For beams under predominant bending moments, the failure mode tends to be lateral-torsional buckling, in which the member buckles laterally out of loading plane and twists. An unrestrained beam is considered when its compression flange is free to displace laterally and rotate. When an applied load causes both lateral deflection and twisting of a member lateral torsional buckling has occurred. Mainly the lateral-torsional buckling strength is influenced by several major variables such as unbraced length, load type and location of applied load, boundary conditions, section type and initial imperfections of geometry and loading. This study is carried out to proven the software result about the deflection and rotation of the corrugated web influence by the opening in the middle of the beam.

The purpose of using corrugated web is that it permits the use of thinner plates which require no stiffening; hence it considerably reduces the cost of beam fabrication with significant weight saving. Sinusoidal opening used in

corrugated web which's increased area for stress distribution in addition to curved edges that causes smooth stress distribution and also provides better performance in strength.

### 1.1 Objectives

- Develop and verify shell finite element models for simply supported I beam with corrugation on web and also provide sinusoidal openings to the corrugated web
- Use the developed shell finite element models to investigate and understand the lateral torsional buckling behavioral characteristics of simply supported beam.
- By utilizing the non linear analysis and FE models to characterize the load- deflection and moment-rotation responses of castellated I beam in lateral torsional buckling state with the help of finite element software ANSYS.

### 1.2 Scope and Limitations

- To study the behavior of lateral torsional buckling of I beam
- Factors affecting lateral torsional buckling

The parametric study was limited to 9.5 meter single spanned steel beams, using software ANSYS.

- Members subjected to a uniform bending moment about the strong axis of the member, when considering lateral-torsional buckling.
- Elastic, homogeneous isotropic material.
- Beams with the same material properties for flanges and web.
- Thin-walled I-shaped beams with equal angles.
- Webs with varying height over the length of the beam considered for parametric study.

## 2. PARAMETRIC STUDY

The main aim of this Master's thesis was to examine how ANSYS, finite element software calculate the max deflection and angle of twist and to explain potential differences in the results. In order to achieve this, a parametric study was carried out where mentioned above were calculated for selected situations in the programs. There are small differences in the sectional data implemented by the

programs, see Table -1. It was therefore expected that the differences are computed. Since exact reference values are needed to make evaluations of the accuracy, the same beams and loading conditions have been suggested as in the research by Mattias Larsson *et al.* (2013) [4], as well as the various web perforations have been proposed by P.D Kumbhar *et al.* (2015) [5].

In all, a group of 15 tests models were performed. The specimens were designed 9500 mm lengths and different sizes of opening. The analysis of the corrugated beam with sinusoidal shaped openings is carried out for different sizes. In this investigation, the nonlinear FEA computations of castellated beam under consideration were performed by using the commercial finite element software package ANSYS 16.2.

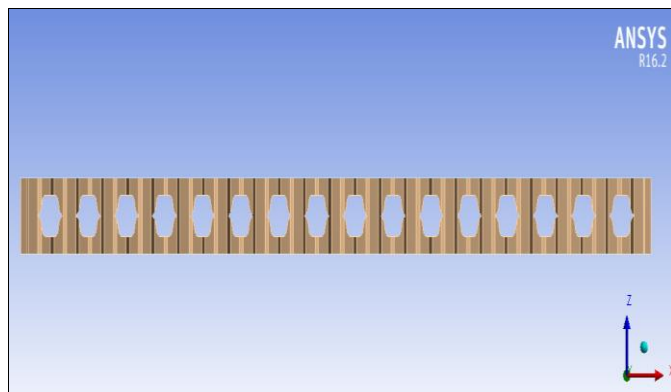

Fig -1: Model of Castellated I beam with trapezoidal corrugation – 2D view

**2.1 Cross Section Geometry**

If nothing else stated, the following labeling of cross-section dimensions are used in the thesis.

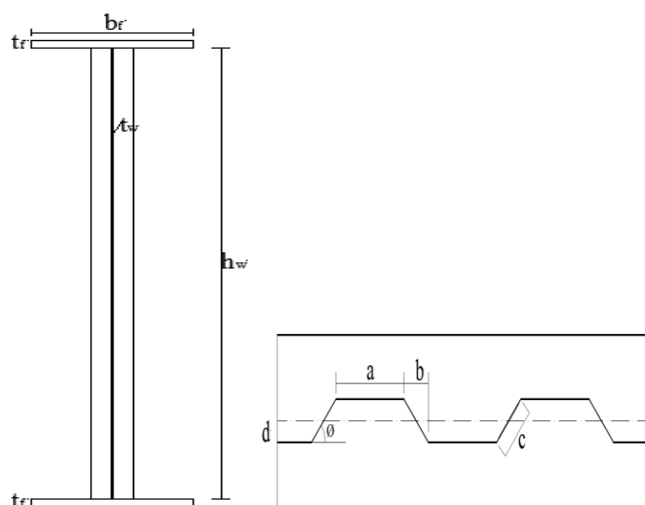

Fig -2: Notations for the geometry of the cross-section and corrugation profile

Table -1: Geometry of corrugated profile

Length L(m)	br (mm)	tr (mm)	hw (mm)	tw (mm)	a (mm)	b (mm)	c (mm)	d (mm)	θ (°)
9.5	200	12	700	2	140	50	71	25	45

The basic terms involved in the analysis and design of castellated beams are illustrated in Fig- 3 [2].

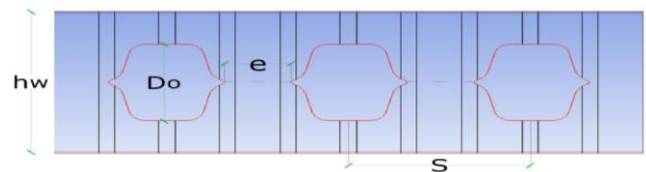

Fig -3: Typical cross section of the castellated beam

The parameter considered for the study is  $h_w/Do$  ratios and  $S/Do$  of the opening. The variations in the parameters and corresponding cross sectional dimensions of the sinusoidal openings are given in Table -2.

Table -2: Parameters considered for sinusoidal opening

Model No	hw (mm)	Do (mm)	hw/Do	S/Do	S (mm)	e (mm)
M 1	700	410	1.707	1.4	574	123
M 2	710	440	1.651	1.4	616	132
M 3	720	470	1.531	1.4	658	141
M 4	730	500	1.46	1.4	700	150
M 5	740	530	1.39	1.4	742	159
M 6	700	410	1.707	1.3	533	123
M 7	710	440	1.651	1.3	572	132
M 8	720	470	1.531	1.3	611	141
M 9	730	500	1.46	1.3	650	150
M10	740	530	1.39	1.3	689	159
M11	700	410	1.707	1.2	492	123
M12	710	440	1.651	1.2	528	132
M13	720	470	1.531	1.2	564	141
M14	730	500	1.46	1.2	600	150
M15	740	530	1.39	1.2	636	159

**2.2 Boundary Conditions and Loading**

In order to have equilibrium some degrees of freedom must always be restrained at the boundary. An important and often mentioned support condition is the fork support.

A fork support is defined to have the following boundary conditions (Fig -4).

- Displacement in x, y and z (Fixed)
- Rotation about x-axis (Fixed)
- Rotation about y-axis (Free)
- Rotation about z-axis (Free)

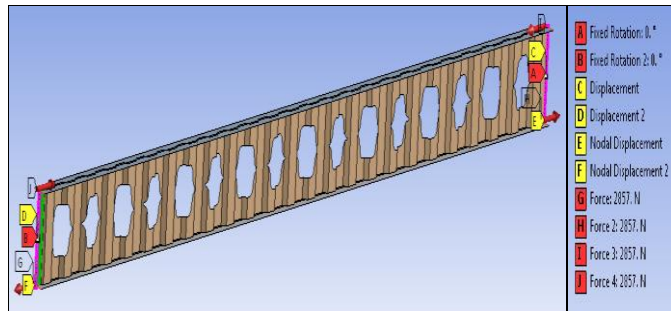

Fig -4: Boundary Condition Application in Software

**3. RESULT AND DISCUSSION**

Comparisons were made between the different parameters changed models of results. Discussions were carried out with respect to the comparisons of load capacities and the mode of failure occurred. The figure Fig. 5 deformed shape of beam with un-deformed form and the region where the maximum and minimum deformations occurred at specified loading.

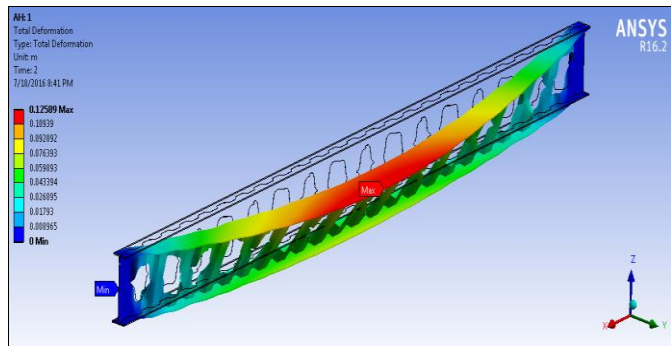

Fig -5: Total deformation of beam at maximum and minimum range

**3.1 Comparative Study**

A comparative study of each FE models from finite element analysis result are carried out for better conclusion of this study. The results from Finite Element Analyses presenting lateral-torsional buckling behavior of the castellated I beam with corrugated webs have been collected shown in Table- 3.

By analyzing the chart -1, 3 models -model M5 (S/Do=1.4), M10 (S/Do=1.3) and M15(S/Do=1.2) have equal web depth and opening size and also their c/c spacing is in increasing order shows comparatively satisfactory performance against loading. They show linear deformation at a particular level, but after that M5 able to carry maximum load at minimum rate of deformation than M10 & M15.

**Table -3: FE Analysis result**

Model No	Load at yield (KN)	Max. Deformation (mm)	Moment of reaction (KNm)	Rotation about x axis (°)
M 1	90	125.89	3.181	0.29691
M 2	173.70	430.65	18.59	0.74906
M 3	92.50	131.91	3.087	0.27204
M 4	170.60	409.73	17.242	0.70695
M 5	106.20	135.78	3.056	0.29955
M 6	170.60	422.237	18.093	0.71696
M 7	92.90	125.08	3.045	0.34833
M 8	90	125.77	3.174	0.34296
M 9	105	172.87	4.671	0.42015
M10	130	274.02	9.282	0.57236
M11	92.90	117.18	2.853	0.28669
M12	171.20	429.25	18.668	0.71284
M13	174.40	417.79	18.113	0.7437
M14	170.70	422.91	18.29	0.67267
M15	170.90	403.31	17.059	0.69956

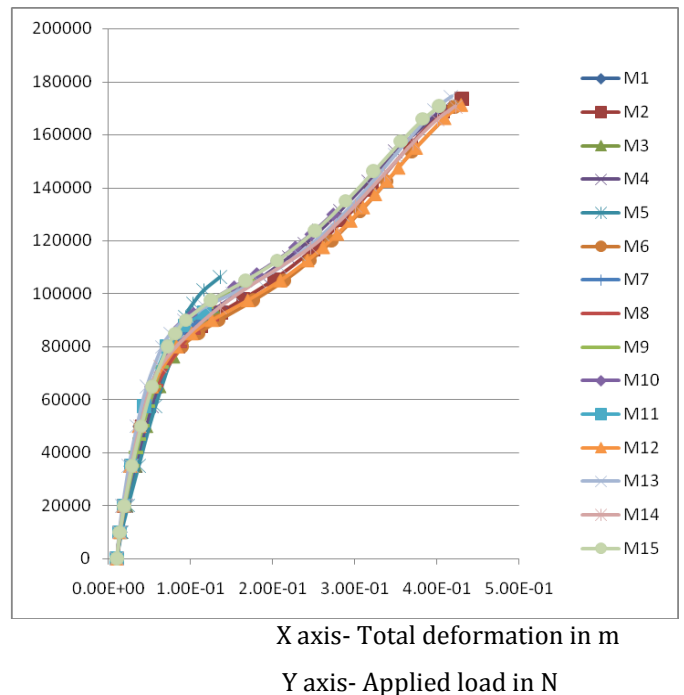

**Chart-1: Load -Deformation curve from FE Analysis**

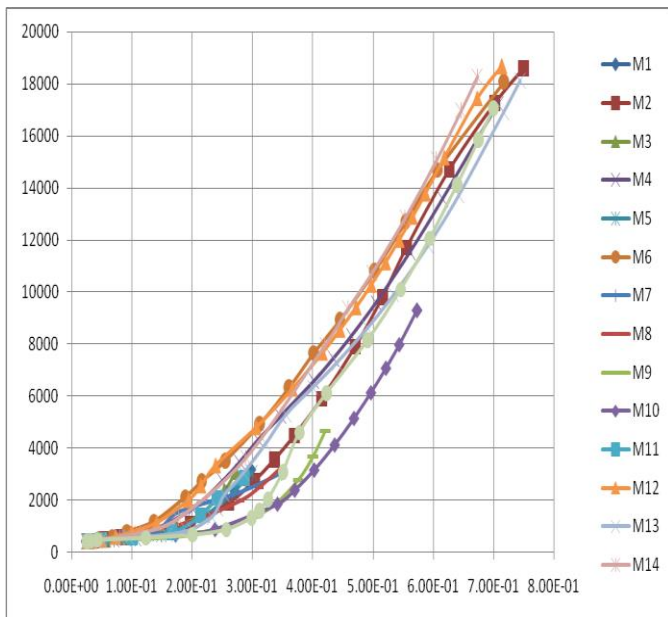

X axis- Rotation about x axis in (<sup>o</sup>)

Y axis- Moment in Nm

**Chart-2:** Moment- Rotation curve from FE Analysis

In general, the FE models capable to the prediction of the complete moment- rotation curve and also to estimate effectively the rotation capacity. The results obtained from the developed FE models show significant effect on the moment- rotation curve.

#### 4. CONCLUSIONS

In this study, lateral-torsional buckling of the inelastic castellated I beam with corrugation profiles of the web has been considered.

- All the specimens failed due to lateral buckling on top compression flange.
- If the models has equal web depth and opening size and also their *c/c* spacing is in increasing order, model with lowest spacing able to carry maximum load at minimum rate of deformation
- The FE models appear capable in the prediction of the complete moment- rotation curve and to estimate effectively the rotation capacity
- Sinusoidal openings give less stress concentration at opening.

#### REFERENCES

- [1] Abdelrahim K. Dessouki, Sherif A. Ibrahim, and Seham A. El-Sa'eed, "Experimental and finite element study on the inelastic lateral buckling behavior of coped I-beams" Housing and Building National Research Center Journal, Vol 11, 2015, pp 339-352
- [2] B. Kovesdi and L. Dunai, "Determination of the patch loading resistance of girders with corrugated webs using nonlinear finite element analysis", Computers and Structures 89, 2011, pp 2010-2019

- [3] H. R. Kazemi Nia Korrani and S. Molanaei, "The Effects of the Corrugation Profiles of the Web on the Lateral-Torsional Buckling Strength of the Inelastic I-Girder" World Applied Sciences Journal 8 , Vol 5, 2010, pp 527-530,
- [4] Mattias Larsson and John Persson "Lateral-torsional buckling of steel girders with trapezoidally corrugated webs" Steel and Timber Structures (Chalmers) (2013)
- [5] P.D. Kumbhar and A.M. Jamadar, "Optimization of Opening Size for Castellated Beam with Sinusoidal Openings", International Journal of Optimization in Civil Engineering, Vol 5(3), June 2015, pp 301-313
- [6] R.Divahar and Dr. P.S.Joanna "Lateral Buckling Of Cold Formed Steel Beam with Trapezoidal Corrugated Web" International Journal of Civil Engineering and Technology (IJCIET) Vol 5, Issue 3, March 2014, pp 217-225