

Roller Chain Link Plate: A Review

Sanil R. Patil¹, P. V. Deshmukh²

¹PG Student, Mechanical Design Engineering, AISSMS COE Pune, Maharashtra, India

²Assistant Professor, Dept. of Mechanical Engineering, AISSMS COE Pune, Maharashtra, India

Abstract - The paper describes the development and description of the Roller Chain Link Plate models used in chain conveyor. This includes a status of the capabilities of FEM analysis and the need for reliable and simpler engineering models. This paper concentrated on FEA of link plate. Roller chains have a long history as mechanical elements for transmission. Although they have clear advantages over belts in terms of performance and efficiency, their larger weight has always been a disadvantage.

Key Words: Boundary Conditions, Loads, Finite Element Analysis, Link Plate, Roller Chain,

(decrease of volume) with the suppression of the increase in stress, the form of the link plate was explored by changing various design parameters. Then, a prototype of link plate made of ABS resin was manufactured under the conditions used for obtaining favorable results in simulated design proposal. Furthermore, the adequateness of the analysis was verified by a tension test. Figure 1 shows the fundamental structure of a roller chain. The dimension of each part is defined in JIS B 1801 or JCAS 1. First, in this research, the stress on a commercially available standard chain was analyzed. Then, when the form of the link plate was changed, the analyzed stress was compared with that of the standard chain.

1. INTRODUCTION

A roller chain is known and used as a mechanical element for drive train or parts conveyance systems. Basically, its mechanism is a type of engaging between a chain and a sprocket wheel. Compared with that in belts, the capacity of transmission in roller chain is large and the efficiency is high owing to the absence of slip. Thus, the mechanism of roller chains is applied to the rear-wheel drive of a bike, the hoist of a fork lift and the valve switching mechanism of an internal-combustion engine. However, when the transmission speed increases, the vibration of the mechanism increases as is the case of gear engagement. In a case of long-distance transmission using a metal chain, a large driving force is required owing to the enlarged mass of the chain. To solve such a problem, weight saving for the chain is desired. Regardless of the above-mentioned background, research on the chain mechanism is rare. Moreover, design research by stress analysis is practically not feasible.

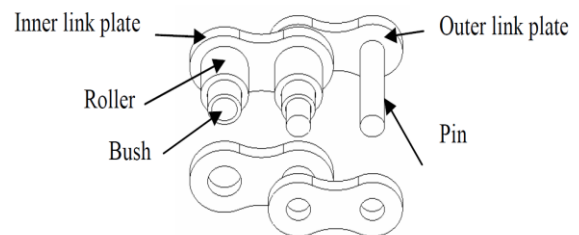

Fig -1: Schematic view of roller chain

2. THREE-DIMENSIONAL CAD MODEL AND CONDITIONS OF FEM ANALYSIS

Noguchi S. et. al., from Kanto Gakuin University^[1], in their research, as the first step of weight saving for the chain, the authors attempted to provide a design solution. That is, weight saving with the suppression of the increase in stress is realized by analyzing the static stress of a link plate in a roller chain by FEM (Finite Element Method). First, the stress of a standard product in accordance with JIS was calculated by FEM for loading static force. Second, the calculated stress has used as a benchmark. Third, considering the weight saving

The shape of a link plate is similar to a gourd with a constricted part. Principal dimensions such as the pitch distance between pins, are shown in JIS. By considering the symmetric properties, mesh segmentation was performed on a quarter model for FEM analysis. The meshed model is shown in Fig.2. This model has 20000 meshed elements. To simplify the analysis of link plate stress, the roller was not regarded because the roller did not support the generated force when the chain was pulled independently.

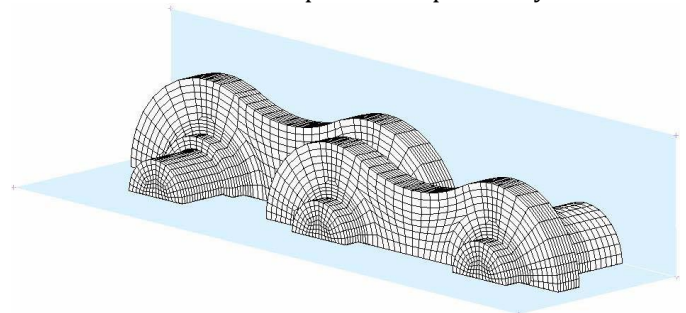

Fig -2: Example of meshed model for FEM

The stress and deformation analyses were performed by applying a static tensile load in the chain direction (X-

direction). The load was not applied to the link plate directly but to neighboring pins (or bushes). The deformations in the nodal points on the symmetry plane were restrained in a plane perpendicular to the symmetry plane.

3. STANDARD CHAIN

A typical conveyor chain is constructed with two different types of shackles: the roller link (or inner link) and the pin link (or outer link), see Figure 3 The roller link consists of two steel bushings that are press-fitted inside the roller link plates, while the pin link consists out of two steel pins press-fitted inside the pin link plates. To prevent disengaging of plates and pins, riveted pins or t-pins (as shown) are used. Conveyor chains can be loaded in two ways: the force can be applied on the side plates by use of attachments which are connected to the side plates, (see Figure) alternately the force can be applied on the pins. Therefore hollow pins and axles instead of solid pins (as shown) are used by S.R.Kale^[2] in his work.

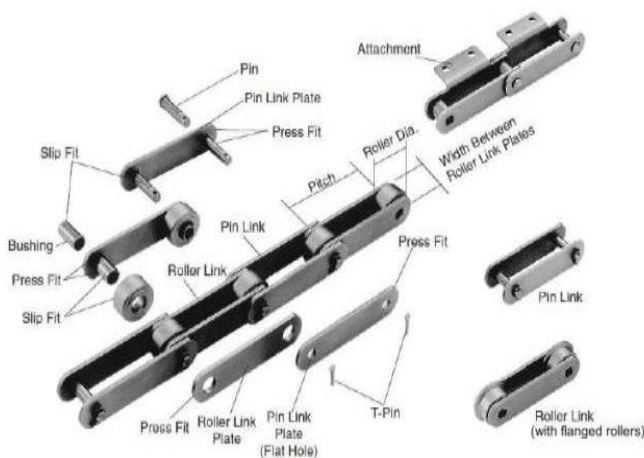

Fig -3: Basic structure of chain.

4. LOAD CONSIDERATIONS

Brage Prashant Ravindra and et al. considered following load.

A. Tensile Load (Nominal Tensile Load)

The main consideration for all types of chain is the nominal tensile load that is required to perform the basic function. The nominal tensile load generally fluctuates in a regular cycle. Figure-4 roughly shows how the tension varies in a chain that is 100 pitches long as it runs around 20-tooth sprockets. This nominal tensile load is the basic load considered in almost all chain ratings.

B. Shock Load

Shock loads are caused by the characteristics of the power source and the driven machinery. They occur repeatedly in a regular cycle, usually one or more times in each shaft revolution.

C. Inertia Load

As the term is used here, inertia loads are different from shock loads. Inertia loads are the occasional loads imposed on the chain by unusual, and often unexpected, events. They may

come from starting a heavily loaded conveyor or a drive with a large flywheel. Or they may be caused by a sudden momentary jam in the driven machine or conveyor.

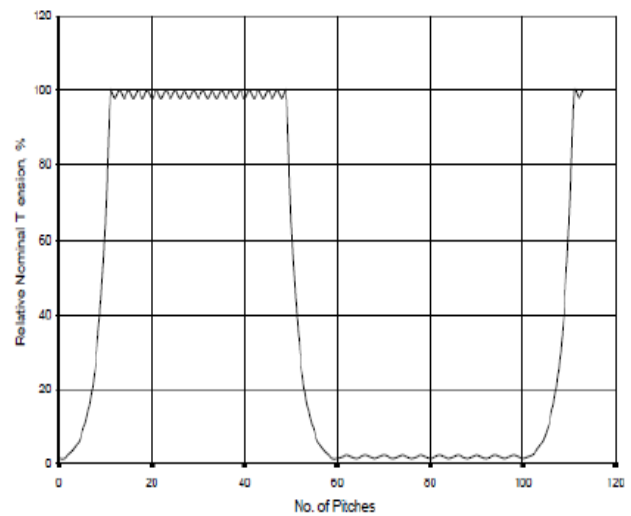

Fig -4: Tension variation in chain

D. Centrifugal Tension

In high-speed drives, centrifugal force is generated as the chain travels around the sprockets. Centrifugal force also may be generated by the chain's travel over a curved path between sprockets.

E. Catenary Tension

The weight of that portion of the chain that hangs in a catenary generates additional tensile loads in the chain.

F. Chordal Action

As the chain wraps a sprocket, it effectively forms a regular polygon. That causes the chain strand to rise and fall each time a joint engages a sprocket tooth. This motion is called chordal action, and the effect is illustrated in Figure-5. The tension in the chain changes slightly every time the chain speed changes.

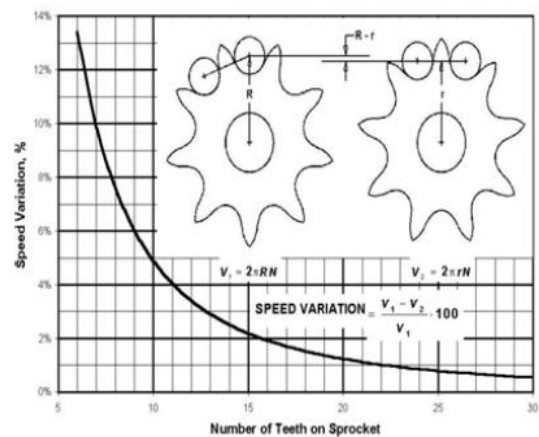

Fig -5: Chordal Action

G. Vibration

Chain vibration can cause very large increases in chain tensile loading if the vibration occurs at or near the natural frequency of the chain.

5. DESIGN CONSIDERATIONS

Roller chains are used in a wide variety of applications, but most roller chain is used in drives. The shaft speeds of the drives range from less than 50 rpm to nearly 10,000 rpm, and the amount of power transmitted ranges from a fraction of a horsepower to more than 1000 hp. The main design considerations for a roller chain to be used on a drive are the various tensile loads.

A. Ultimate Tensile Strength

The ultimate tensile strength of a chain is the highest load that the chain can withstand in a single application before breaking. It is not a major consideration in designing roller chains. It is only important because yield strength and fatigue strength depend on ultimate tensile strength. Minimum ultimate tensile strength (MUTS) is a requirement in the ASME standards that govern roller chains. A well-made roller chain almost always meets the standard.

B. Yield Strength

The yield strength of a chain is the maximum load from which the chain will return to its original state (length). For many standard chains, the yield strength is approximately 40% to 60% of the minimum ultimate tensile strength.

Figure-6 shows a typical load elongation diagram for chain. The figure clearly shows that the yield point for the particular chain shown is at 60% of the ultimate tensile strength. Yield strength is an important consideration in designing roller chains. For standard roller chains, conforming to ASME, the yield strength is about 60% of the MUTS. Figure-4 is a diagram of how a standard roller chain elongates as a tensile load is applied.

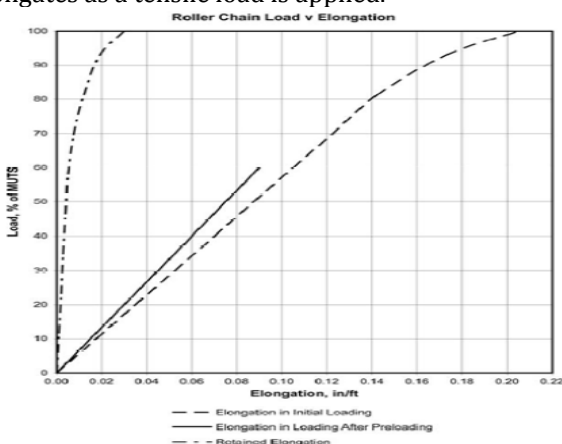

Fig -6: Standard roller chain elongates as a tensile load is applied

6. FINITE ELEMENT ANALYSIS

The model is a link with three cutouts that is created in modeling software. Fig.7 shows the basic structure and components of roller conveyor chain and the different types

of fits assembled under working conditions. Main components of roller conveyor chain are pin, link plate (strip), bushing and roller. The pin link plate i.e. strip is the assemblies of two pins that are press fitted into the holes of two pin link plates.

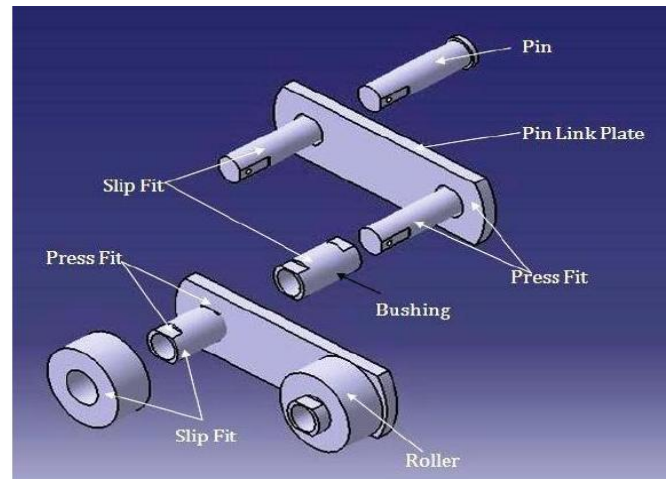

Fig -7: Basic structure of roller chain

The press fit between pin and the pin link plate prevents the pin from rotating. Usually there is a repeated loading, sometimes accompanied by shock. The pin is subject to shearing and bending forces transmitted by the plate. There is slip fit between bushing and pin. The bushing is subject to shearing and bending stresses transmitted by the plate and roller, and also gets shock loads when the chain engages the sprocket. In addition, when the chain articulates, the inner surface forms a load-bearing part together with the pin. The outer surface also forms a load-bearing part with the roller's inner surface when the roller rotates on the rail or engages the sprocket. There is slip fit between the bushing and the roller. The roller is subject to impact load as it strikes the sprocket teeth during the chain engagement with the sprocket. After engagement, the roller changes its point of contact and balance. It is held between the sprocket teeth and bushing, and moves on the tooth face while receiving a compression load. A major advantages of roller chain is that the rollers rotate when contacting the teeth of the sprocket.

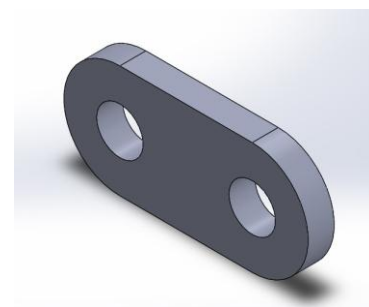

Fig -8: link Plate of roller chain.

FEA modeling consisting of modeling of chain link, preprocessing, processing and post processing in ANSYS Workbench 12.0. 3D Hex Dominant mesh type is used for meshing the 3D model in ANSYS Workbench 12.0 .Single

entity set named as Mesh body consisting of total solid body is created. Second order Solid95 element type is used for analysis. Three different element sizes are used as 1mm, 2.5mm and 5mm for refinement for checking divergence.

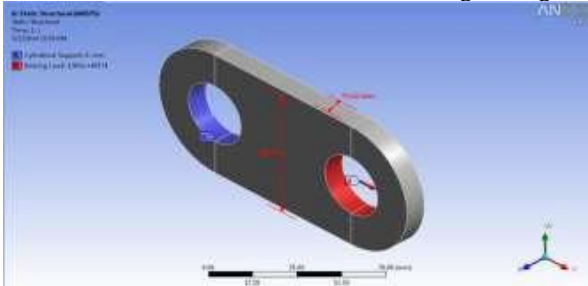

Fig -9: Boundary Conditions of Link Plate

Mr. Brage P. R. made inner surface of one hole of link plate is fixed and load is applied on inner surface of another hole link plate. S. Noguchi drawn only 1/4th part of link plate as remaining part is symmetrical so the time required to do the analysis is reduced considerably. Whereas S.R. Kale applied load on inner surface of both holes of link plate in such a manner that link plate is in tension. Fig 9 shows the boundary conditions of Mr. Brage P.R

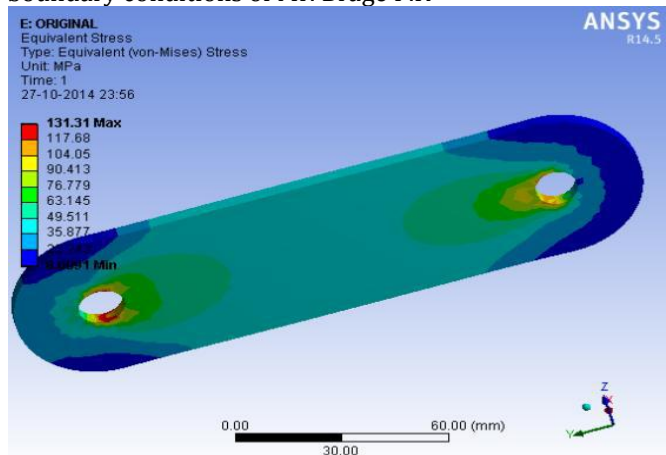

Fig -10: Stresses in Link Plate

Fig. 10 shows analysis results for stresses in link plate. Stresses are maximum in hole region in transverse direction of applied load.

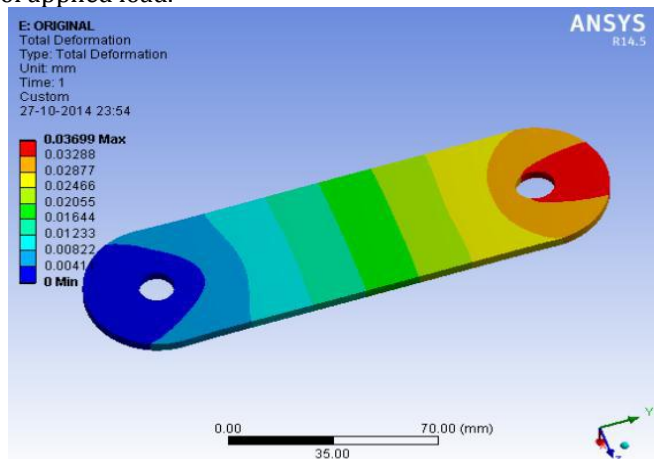

Fig -11: Deformation in Link Plate

Deformation is maximum at the end where load is applied and minimum at other end which is fixed as shown in fig. 11.

7. CONCLUSIONS

The Chain is the most important element of the industrial processes required for transmitting power and conveying of materials. As these chains operate under various forces, failure of chain assembly is the major problem. Causes of these failures are improper material selection, uncertainties in manufacturing, faulty manufacturing processes. The objective of this study was to design link plate of roller chain and analyzed the boundary conditions applied in FEA software and critical areas of the link plate from solution.

ACKNOWLEDGEMENT

The authors are thankful to Mr. Sunil Gaikwad, Dattachaya Chains Pvt. Ltd. Kolhapur for their constant encouragement and cooperation throughout the work.

REFERENCES

- [1] Noguchi S, Nagasaki K., Nakayama S, Kanda T., Nishino T. and Ohtani T., "Static Stress Analysis of Link Plate Of Roller Chain using Finite Element Method and Some Design Proposals for Weight Saving", Journal of Advanced Mechanical Design, Systems, and Manufacturing, Vol 3.No2, 2009, pp. 159-170.
- [2] Fujiwara, Tanimura, Testsuo, Bearing Roller chain, U.S.Patent US7, 972,233, B2, Jul 2011.
- [3] Tushar D. Bhoite, Prashant M. Pawar, "Finite Element Analysis based Study of Effect of Radial Variation of Outer Link in A Typical Roller Chain Link", International Journal of Mechanical and Industrial Engineering (IJMIE), ISSN No. 2231 -6477, Vol 1, Issue4, (2012) pp. 65-70.
- [4] M. Koray, M. Cuneyt M, Erdem C., "Stress Distribution of the Chain Link by Means of Boundary Method", Journal of Engineering and Natural Sciences, Sigma 04.11.2004 pp. 255-263.
- [5] Brage P. R., Prof. V. H. Waghmare, Mr. S.D.Chavan, "Roller Chain Link Plate Design Based on FEA" International Journal on Recent and Innovation Trends in Computing and Communication, Vol. 2, Issue 12, (2014) pp. 4109-4113.
- [6] Tushar.S.Shahane, Prof.Ameeth.M.Umbrajkaar, "Design And Analysis Of Chain Outer Link By Usin Composite Material", IOSR Journal of Mechanical and Civil Engineering (IOSR-JMCE), Volume 12, Issue 1 Ver. II, Jan- Feb. 2015, pp. 46-50.
- [7] S.R. Kale, R.R.Navthar, "Analysis and Optimization of Chain Conveyor Outer Link", International Journal of Innovative Research in Science, Engineering and Technology, Vol. 4, Issue 8, August 2015, pp. 7197-7206.