

COMPARISON OF FEATURES EXTRACTION AND PARAMETERS OF DIFFERENT ECG SIGNALS USING LABVIEW

Deepa Paul¹, Ram Avtar Jaswal²

¹P.G Scholar, Electrical Engineering, UIET Kurukshetra University, Haryana, INDIA

²Assistant Professor, Electrical Engineering, UIET Kurukshetra University Haryana, INDIA

Abstract - This paper determine the parameters of different ECG signals from MITBIH data base to check whether the signal is noisy or not because students get stuck into puzzlement that which ECG signal is correct or which one is not. By using LABVIEW we can predict the noisy signal and ECG signal parameters and their features to compare the overall results and calculations. Very few people are aware of this software i.e. LABVIEW which is more convenient for signal processing, power system and calculations etc rather than any other software

Key Words: ECG parameters, filters, features extraction, LABVIEW Biomedical Toolkit, MIT-BIH data base.

1.INTRODUCTION

The ECG is a graph which represents the activity of the heart by placing electrode on the leg and the arms of the body is called an electrocardiogram, thus signal has been shown on ECG is known as ECG signal. These signals always change with time (non-stationary) so it is very difficult to examine the behavior of patients in a graph. Because, when signals are acquired during ECG is often filled with noises i.e baseline wandering, powerline interference, electrode pop, breathing, etc change the characteristic, interval between P-QRS-T waves, behavior of the signal.

ECG contains both time and frequency components of a signal to get the proper diagnosis of patients that is not possible by ECG machine. ECG signal is non-stationary signals, hence it changes with time so it very difficult to proper diagnosis the disease of heart patients. An ECG signals represents heartbeats consisting of P Wave, QRS Wave, T Wave and U Wave. The amplitude, duration and interval between each of these waves help us distinguish between normal and abnormal waveforms.

The ECG ranges from a few μV to about 1V in magnitude. Whereas the characteristic waves of P-

QRS-R signal of ECG becomes change if abnormality is arisen in each interval during breathing, the P wave is occurring due to depolarization of atria QRS wave is shown when depolarization of ventricular and T wave is because of repolarization of ventricular. The main problem arises is the noise which depends upon different amplitude of a wave is measured with reference to the ECG baseline level, commonly defined by the isoelectric line. These noises are effected the original signal, i.e baseline wandering("it is usually comes from respiration at a frequency between 0.15 to 0.3 Hz"), electrode pop ("shake of wire during coughing, breathing of patient"), power line interference ("Narrow frequency with 50 Hz noise from power lines it is necessary to remove is called power line interference removal") and others wideband noise of ECG signal .

The human heart consists of four chambers, two artia called upper chambers and two ventricles called lower chambers. Under healthy condition of the heart these chambers beat in an organized manner. The standard ECG waveform for one cardiac cycle in figure 1 as shown below

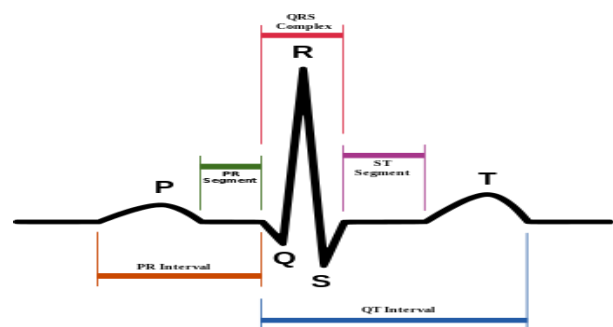

Figure 1 one cardiac cycle of ECG signal

II. LABVIEW EXPERIMENT

In these paper signal is described by using LABVIEW software with biomedical toolkit and add a noise in ECG signal which is acquired from MIT-BIH database to identify the problem related to the heart. In clear signal some noises are suppressed already so it becomes difficult to check which noise is occurring. Some noises did not remove by hardware technique to read deeply the signal we can use LABVIEW software, MATLAB software etc to understand the signal. LABVIEW is a virtual instrument software, namely, VI famous in Various way, such as: signal processing, calculation, feature extraction of any signal, etc. But we use LAVBIEW software for comparison the parameters of two different types of ECG signal to investigate the noisy and original signal. In this paper our work can be divided into three different parts, which are:

- i. Feature extraction of original signal.
- ii. Feature extraction of noisy signal.
- iii. Feature extraction of denoise signal.

Feature extraction of original signal:

Generally, ECG signal is acquired from MIT-BIH data base or from www.physionet.org. Physionet>>physiobank>>physiobankATM>> Database. The acquiring of original ECG signal as shown in figure 2.

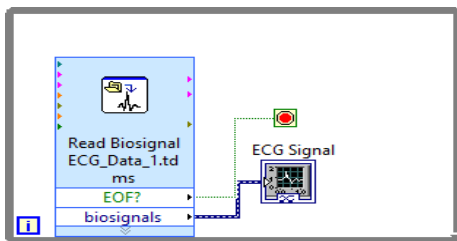

Figure2. Acquiring ECG signal

After acquiring the ECG signal Feature Extractor VI is used to extract the ECG feature i.e heart rate, QRS amplitude, PR interval, QT interval etc. The proposed system of features extraction of the original signal as shown in figure 3.

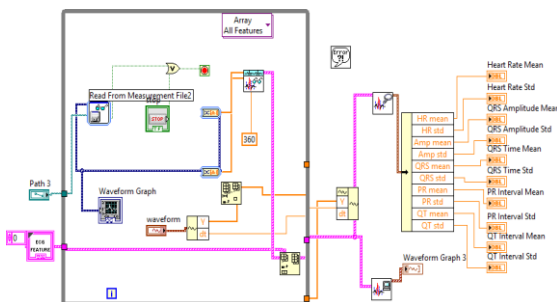

Fig. 3 Features extraction of original signal

The ECG signal and calculated parameter of this original signal as shown in figure 4.

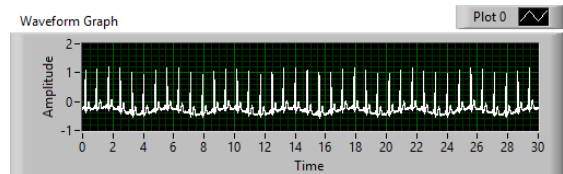

Fig. 4(a) Original ECG signal

Heart Rate Mean	QRS Amplitude Mean	QRS Time Mean	PR Interval Mean	QT Interval Mean
52.99 bpm	1.46 mV	0.106 s	0.208 s	0.664 s
Heart Rate Std	QRS Amplitude Std	QRS Time Std	PR Interval Std	QT Interval Std
10.3 bpm	0.273 mV	0.031 s	2.446E-15 s	0.134 s

Fig. 4(b) calculated parameters of the original signal

Feature extraction of noisy signal:

To attain a noisy signal few point need to keep in mind is:

- Firstly, Check the acquired signal is noisy or not.
- If not, then you can add noise in your signal.

Here, we add noise in original ECG signal and then extract the features by using Feature Extractor VI in LABVIEW. The purposed block diagram has been shown in figure 5

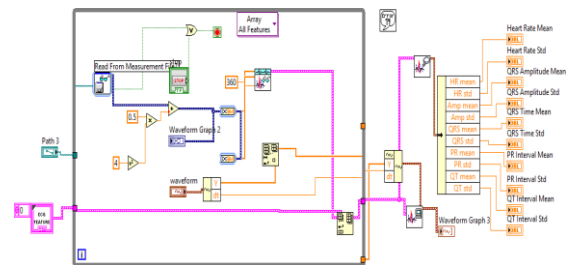

Fig. 5 Feature extraction of noisy signal

The noisy ECG signal and calculated parameters of noisy signal as shown in figure 6.

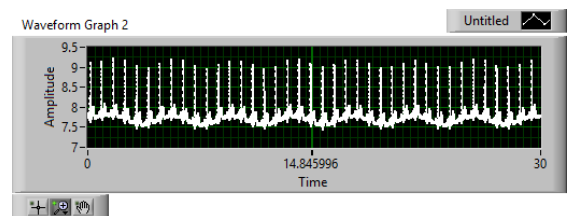

Fig. 6(a) Noisy ECG signal

Heart Rate Mean	QRS Amplitude Mean	QRS Time Mean	PR Interval Mean	QT Interval Mean
103.68 bpm	1.467 mV	0.374 s	0.147 s	0.535 s
Heart Rate Std	QRS Amplitude Std	QRS Time Std	PR Interval Std	QT Interval Std
66.54 bpm	0.232 mV	0.455 s	2.418E-15 s	0.165 s

Fig. 6(b) Calculated parameters of noisy signal

Features extraction of denoise signal:

Often ECG signal filled with noise i.e baseline wandering noise, powerline interference, wideband noise, electrode pop, etc. Among of these noises powerline interference and baseline wandering are strongly effect the ECG signal. Baseline wandering is the low frequency noise and powerline interference is mainly 50Hz or 60Hz noise. To remove the baseline wandering, WA Detrend VI is used. After detrending the signal becomes smooth. Wavelet Denoise technique is used to remove the noise from ECG signal. The wavelet transform are of two types :

Continuous wavelet transform: The wavelet means a “small wave”, which maps a function f(t) into the time-scale plane and is denoted by Ws (a,b) and given by

$$Ws(a, b) = \frac{1}{\sqrt{a}} \int_{-\infty}^{\infty} f(t)h * \left(\frac{t - b}{a} \right) dt$$

Where h(t) is called mother wavelet , a is the scaling parameters in y- axis and b is the shift parameter in x-axis.The The signal f(t) can be recovered from the wavelet coefficients Ws(a,b) by the inverse wavelet transform and is given by:

$$f(t) = \frac{1}{c} \iint_{-\infty}^{\infty} Ws(a, b)h\left(\frac{t-b}{a}\right) \frac{da}{a^2} db$$

Discrete wavelet transform: The DWT is non-invariant and non-redundant in its nature. The time invariant property is useful for feature extraction. It is based on sub-band coding performed fast computation of wavelet transform. It is easy to implement and reduces the computation time and resources required. In case of DWT , by using digital filtering technique we can represents a time scale of digital signal and to analysis the signal, it is necessary to pass through filters with different scales and cutoff frequency

A general equation for DWT signal is written as:

$$X[a, b] = \sum_{n=-\infty}^{\infty} x(n)\Phi_{a,b}(n)$$

Where x(n) is the input signal to be analyzed

Where $\Phi_{a,b}(n) = \frac{1}{\sqrt{a}} \Phi\left(\frac{n-b}{a}\right)$

After denoise the ECG signal parameters are calculated. The purposed block diagram as shown in figure 7.

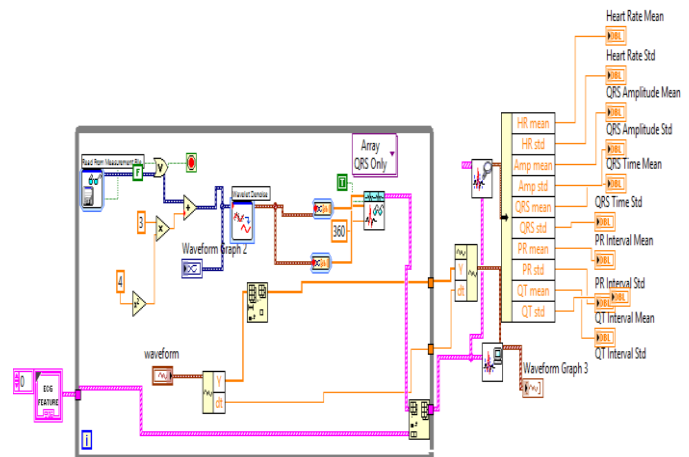

Fig. 7 Features extraction of denoise signal

Heart Rate Mean 98.67 bpm	QRS Amplitude Mean 1.164 mV	QRS Time Mean 0.546 s
Heart Rate Std 62.99 bpm	QRS Amplitude Std 0.618 mV	QRS Time Std 1.448 s

Fig. 8 Parameters of denoised signal

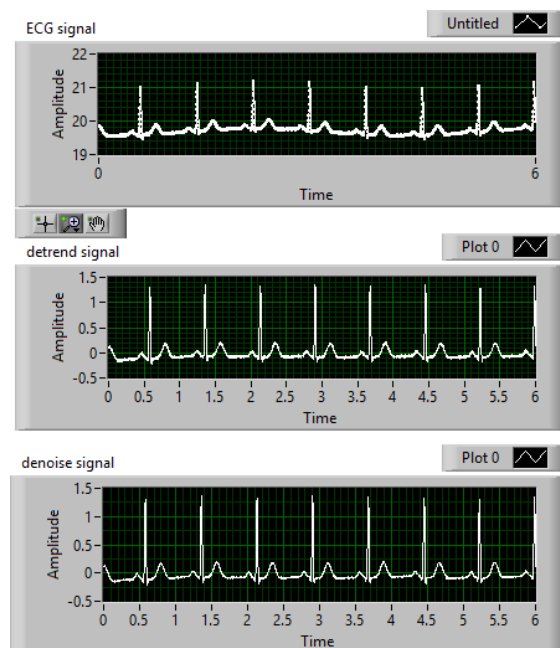

Fig. 9 waveform of denoised signal

This above ECG waveform are of 2 lead ECG waveform to calculate the parameters of Original, noisy and denoised signal with waveform graph. We can easily observe that original signal was started from 19.9 amplitude and after detrending we get the signal at base level i.e start from 0, then last but not least denoise signal is clear from noise as shown in above figure.

Table 1. Parameters of different ECG signal

Parameters	Original signal	Noisy signal	De-Noise signal
Heart Rate (HR) mean	52.99 bpm	103.68 bpm	98.67bpm
Heart Rate(HR) std	10.3 bpm	66.54 bpm	62.67 bpm
QRS Amplitude mean	1.46 mV	1.467 mV	1.164 mV
QRS Amplitude std	0.275 mV	0.232 mV	0,618 mV
QRS Time mean	0.106 s	0.374 s	0.546 s
QRS Time std	0.031 s	0.455 s	1.148 s
PR Interval mean	0.208 s	0.147 s	0.156 s
PR Interval std	2,466e ⁻¹⁵ s	2.418e ⁻¹⁵ s	3.53 ⁻¹⁵ s
ST Interval mean	0.644 s	0.535 s	0.263s
ST Interval std	0.314 s	0.165 s	0.445s

CONCLUSION: This paper identifies the ECG signal at a different level to calculate the parameters and denoised using wavelet transform because wavelet is the smartest way to read both information in the time domain or in frequency domain, so, there is no possibility of loss information which create many problems regarding ECG to diagnosis the disease. With the help of a Labview tool kit we can read real time signal by NI-DAQ in computer or laptop.

III. RESULTS: Overall result demonstrates the parameters of denoised signal is better than noisy and original signal in case of features extraction, parameters. Hence, it proves signal is contaminate with noise and it can be removed with the help of LABVIEW. In the above table, every parameters are calculated for sake of comparison between different ECG signal easily and make the calculation accurately.

REFENECES :

[1] Analysis , Detection and classification of ecg signal for myocardial infarction using simple cross correlation function akhila. n1, tessamma thomas2 former student, retired professor, department of electronics, cochin university of science and technology, cochin, kerala, india.

[2]. S. Z. Mahmoodabadi, A. Ahmadian, and M. D. Abolhasani, "ECG Feature Extraction using Daubechies Wavelets," Proceedings of the fifth IASTED International conference on Visualization, Imaging and Image Processing, pp. 343-348, 2005

[3]. automatic classification of ecg signals with features extracted using wavelet transform and support vector machines sambhu d.1, umesh a. c.2 m.tech student, department of ece, rajiv gandhi institute of technology, kottayam, india1 asst. prof, department of ece, rajiv gandhi institute of technology, kottayam, india2

[4]. ECG arrhythmia classification based on logistic model tree mahesh1, a. kandaswamy2, c. vimal2, b. sathish2 , 1 department of information technology, psg college of technology, coimbatore, india; 2department of bio-medical engineering, psg college of technology, coimbatore, india. email: vm@ity.psgtech.ac.in; hod@bme.psgtech.ac.in; vimalfu@gmail.com; satfrd@gmail.com .

[5]. ECG arrhythmia by Wikipedia .

[6]. M. K. Islam, A. N. M. M. Haque, G. Tangim, T. Ahammad, and M. R. H. Khondokar , "Study and Analysis of ECG Signal Using MATLAB & LABVIEW as Effective Tools" International Journal of Computer and Electrical Engineering, Vol. 4, No. 3, June 2012 [4] Deepa annamalai, s.muthukrishnan,,".

[7] <http://physionet.org/physiobank/database/mitdb/>