

# IWD BASED LOW LEVEL HARMONIC REDUCTION TECHNIQUE IN CASE OF MULTILEVEL INVERTERS

Kunal<sup>1</sup>, Geena Sharma<sup>2</sup>

<sup>1</sup>M.tech(EE), Baddi University, Himachal Pradesh, India

<sup>2</sup>Astt. Prof.(EE), Baddi University, Himachal Pradesh, India

\*\*\*

**Abstract** - The widespread use of harmonics-sensitive digital gadget are developing a near-epidemic of "power high-quality" problems, which might be being addressed by means of both customers and providers of electric energy. Numerous types, styles, and abilities exist within the field of instrumentation and diagnostic system for the detection, recording, and analysis of the harmonics distorted waveform. The essential shortage is in experienced strength machine engineers who can interpret the facts, diagnose the problems, and propose practical answers. This review is one attempt to employ Artificial Intelligence (AI) or intelligent water drop algorithm inside the Harmonics analysis expert system(HAES). The aim is to perform the analysis on the manner of applying this AI method that includes: (1) schooling the consumer, (2) measurements (non-obligatory), (3) prognosis, and (4) to answer the strength of the system for harmonics disturbances to acceptable power.

**Key Words:** AI(artificial intelligence); power; iwd(intelligent water drop ).

## 1. INTRODUCTION

Energy gadget harmonics are higher-order' frequency currents and voltages superimposed on the respective fundamental (60 Hz) frequency waveform. They're induced often by way of non-linear loads such as arc furnaces, diode and thyristor rectification equipment, fluorescent and excessive-stress discharge lighting, switched strength elements in computer systems, and uninterruptible energy systems (UPS). Extra resources of harmonics include saturation of present day loads and capacity transformers (inclusive of ferro resonance) and over excitation and inrush of power transformers as well as synchronous generators (on the whole winding pitch thing selection in salient pole machines). Power system harmonics have constantly been around in electrical distribution systems. However, their nuisance (and, in lots of cases, adverse results) are becoming greater conventional for the subsequent motives: increasing quantity of harmonic

sources, e.g. DC drives, AC drives, arc furnaces, mills and computers with greater stringent energy thing correction necessities resulting within the installation of capacitor banks for improved performance of utilization device, thereby lowering the powerful damping in the gadget there are many ways that harmonics-associated troubles may be manifested depending upon the topology of the machine and the source of the harmonics. Some of the greater commonplace signs and symptoms consist of capacitor fuses failing, capacitor cans rupturing, malfunction of computer monitoring, lower in motor performance because of nuisance tripping of protective gadgets and thermal failure of motors; pulsing torques, immoderate transformer heating and communications controls interference of generator overheating and impartial conductor thermal failure & immoderate neutral voltage drop. Knowledge of the device and cautious evaluation of the electrical waveforms gift inside the system are required to determine whether or not harmonics are certainly causing the trouble or symptom. With this expertise of the machine and its performance, diverse reasons and solutions can be evaluated.

### 1.1 AI(artificial intelligence)

Intelligent Water Drops formula (IWD) [12] may be a swarm based nature-inspired improvement formula, that has been inspired from natural rivers and the way they realize nearly best path to their destination. A natural stream typically finds smart ways among legion doable ways in its ways that from the supply to destination. These close to best or best ways follow from actions and reactions occurring among the water drops and also the water drops with their riverbeds. Within the IWD formula, several artificial water drops collaborate to vary their atmosphere in such some way that the best path is discovered because the one with the bottom soil on its links. The solutions are incrementally constructed by the IWD formula. Consequently, the IWD formula is usually a constructive population-based optimization formula. The Intelligent Water Drop, IWD for short, flows in its atmosphere has 2 necessary properties:

- the number of the soil it carries currently, Soil (IWD).
  - the speed that it's moving currently, speed (IWD).
- This atmosphere depends on the matter at hand. In an environment, there are sometimes legion ways from a given source to a desired destination, that the position of the destination is also glorious or unknown. If we all know the position of the destination, the goal is to search out the most effective (often the shortest) path from the supply to the destination. In some cases, in which the destination is unknown, the goal is to search out the optimum destination in terms of value or any appropriate live for the matter.

## 1.2 REVIEW FOR COMPENSATION OF HARMONICS

To lessen the harmonics content is to limit the THD for the output section voltage of inverter up to 50 harmonics is considered to calculate the THD. the use of Switching angles specific lower order dominant harmonics are suppressed. This approach is known as selective harmonic removal (SHE) or programmed PWM technique in technical literatures [1]. THD of multilevel inverters with unequal dc resources is a first technique and Integrating waveform is 2nd approach the usage of this attain the outcomes are faster, easier, and preferably accurate[2]. SHE-PWM a five level voltage source inverter with elimination of 11 low-order harmonics is investigated. The SHEPWM equations which can put off harmonics from 5th to 35th with modulation index  $M$  varying from 0 to one.15 are formulated [3]. DFCM converter used to doubling the voltage levels and enhance the output voltage frequency spectrum this can be carried out through adding most effective low-power switches and one dc voltage source [4]. The unbalanced degree of the reimbursement currents that the star connected STATCOM can cope with is restricted to the maximum practicable output voltage of the converter leg. Additionally the dc-hyperlink voltages of the star connected cascade converter were correctly managed during the unsymmetrical fault [1]. Reference rotation technique rotates the modulation waveform through special bands of carrier waveforms with the aid of the use of line-line redundant voltage states. This uses all of the degrees in the inverter even at low modulation indexes. The provider commonplace-mode dc-offset method to increase the voltage stages and reduce harmonic current distortion at low modulation indexes the series-linked IGBTs inside the 3-degree unidirectional greenback and enhance choppers resulted in right voltage sharing. also reducing the switching frequencies of the IGBT's[4].the nature of a low-voltage step inside the inverter output makes a large contribution to

decreasing motor modern ripple and the resultant motor torque ripple, as well as to mitigating unwanted outcomes of common-mode voltage on ground leakage contemporary and/or bearing contemporary[3]. based totally on one-of-a-kind switching states, it's miles feasible to attain extra voltage tiers on output voltage by including and subtracting dc hyperlink voltages compared with traditional multilevel inverters with the same variety of components .By doing so, output voltage with advanced pleasant can be received with less circuit and manipulate complexity. Additionally, growing the harmonic function of the output voltage can lower the dimensions of the filter. the main advantage of this arrangement is the simplicity to cascade numerous H-bridge cells for development of the output voltage resolution with reduced variety of components[6].SHE-PWM techniques offer numerous blessings over other modulation techniques, such as perfect overall performance with low switching frequency to fundamental frequency ratios, direct manage over output waveform harmonics, and the capacity to depart triple harmonics uncontrolled to take gain of circuit topology in three phase systems, and therefore have drawn incredible attention in latest years. SPWM technique and also reduces switching frequency with the same waveform exceptional within the full range of modulation index. To get rid of higher order of harmonics by honestly producing the opposite of the harmonics to cancel them[8].assessment among 3 styles of stability manage strategy, particularly, the active voltage vector superposition, modulation index law, and phase shift perspective law has been suggested in for delta-linked twelve stage CHI topology controlled by CB-PWM. It changed into concluded that the former offers precise control performance with robust law capability accompanied by the segment shift perspective law technique and modulation index law method.

A hybrid power conditioner for solving the problems of harmonic currents and neutral-line current in three-phase four wire distribution power systems. This hybrid power conditioner is configured by a neutral-line current attenuator and a hybrid power filter. The hybrid power filter, configured by a three-phase power converter and a three phase tuned power filter, is utilized to filter the nonzero-sequence harmonic currents in the three-phase four-wire distribution power system. The neutral-line current suppressor is connected between the power capacitors of the three-phase tuned power filter and the neutral line to attenuate the neutral-line current in the three-phase four-wire distribution power system. The hybrid power conditioner can effectively reduce the power rating of passive and active elements. A hardware prototype is

developed to verify the performance of the hybrid power conditioner.

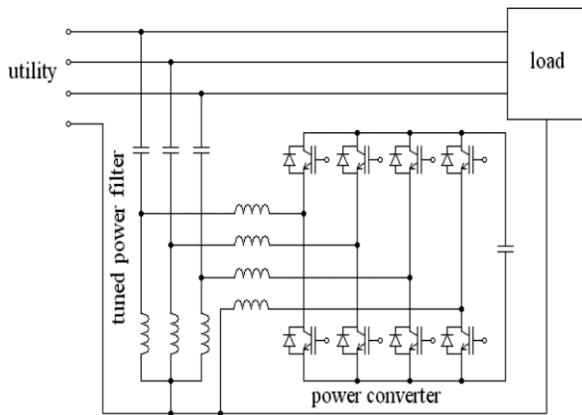
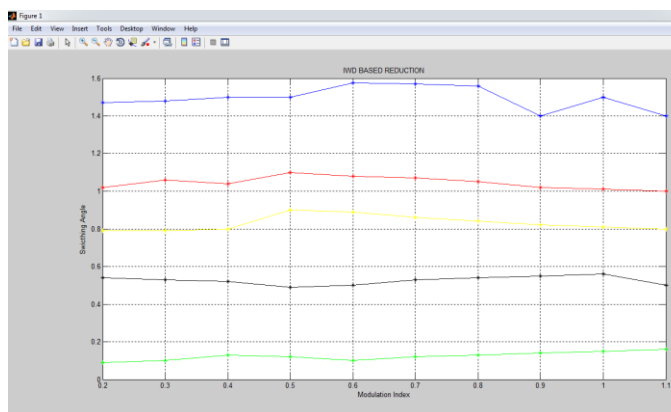

Fig. 1. Configuration of the advanced hybrid power filter.

Fig.2. Flow comparison of IWD with GA



### Placement of harmonic compensation unit in micro grid system

In conventional methods [9], [10], the series harmonics reduction units are placed at the grid side, as shown in Fig. 1 where the objective is to make the line impedance at the harmonic frequency as high as possible. From Fig. 3, the mesh the compensation unit pushes voltage harmonics to make the grid current harmonics free; however, this voltage harmonics distort the PCC voltage. Moreover, during the SA mode of operation, the grid branch is disconnected making the compensation unit idle.

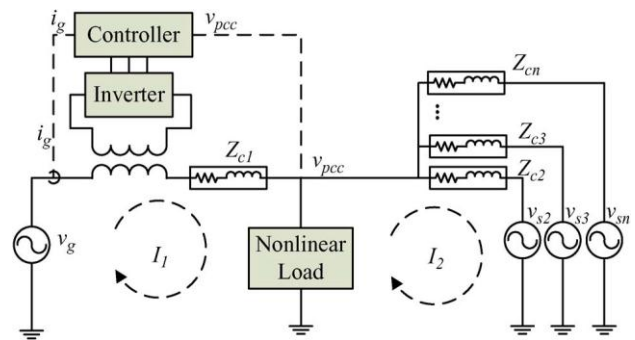

Fig. 3. Configuration of the conventional shunt-type hybrid power filter.

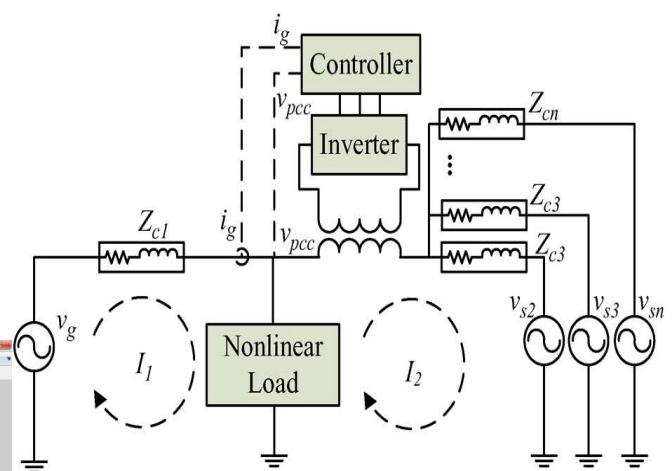

Fig. 4. Harmonic compensation method.

This placement for the harmonics injection unit in this research is the distributed generation side, as shown in Fig. 4. In this case, the objective of the harmonic compensation unit is to make the impedance in the sources of the micro grid side as small as possible to divert all the current harmonics far from the grid side.

A nineteen-level CHI-based STATCOM to simultaneously balance the dc-hyperlink capacitor voltages, decrease the inverter switching losses, and provide exact current reference monitoring [10]. Removal principle has been employed to decide the switching angles to do away with specific harmonics, together with the fifth, 7th, eleventh, and the 13th. The benefit of the essential frequency switching approach is its low switching frequency compared to other manages technique [12]. Switching losses in those excessive-strength excessive-voltage converters represent a trouble and any switching transitions that can be removed without compromising the harmonic content of the final waveform is considered high-quality. The term multilevel starts with the creation of the three level converters. via growing the range of ranges in a given topology, the output voltages have more steps producing a staircase waveform, which methods closely the favored sinusoidal waveform and additionally

gives decreased harmonic distortion. An optimization method assisted with a hybrid genetic set of rules became correctly applied to find the switching transitions of the SHE-PWM ac/ac converter [9]. The cascaded inverters is generating the whole output energetic electricity and the opposite inverters are used as a assist to improve the output voltage waveform the main capabilities of this topology are the inherent galvanic isolation, bidirectional power waft, discount of the transformer length and weight, and high efficiency[10].

## 2. HARMONIC REDUCTION

Enhancing the efficiency of the multilevel inverter and for the high-quality of output voltage waveform, seven stages reduced switches topology has been applied with handiest seven switches. Fundamental Switching scheme and Selective Harmonics removal have been carried out to reduce the overall Harmonics Distortion (THD) value. Selective Harmonics removal Stepped Waveform (SHESW) method is implemented to eliminate the decrease order harmonics. Fundamental switching scheme is used to govern the energy electronics switches within the inverter. The topology is suitable for any range of levels. The harmonic reduction is finished by using deciding on suitable switching angles. In multilevel inverter using 5 identical dc assets, the 5 switching angles were determined such that the 5th, 7th, eleventh, and thirteenth order harmonics had been eliminated while on the identical time controlling the fee of the fundamental. The idea of Symmetric Polynomials changed into used along with resultant idea to remedy the corresponding set of polynomial harmonic equations for all feasible switching angles.

### 2.1 Artificial intelligence for distortion minimization

In this we describes the development of a harmonics analysis professional system designed to enhance the information of the electricity systems engineer within the pursuit of a correct diagnosis of strength system running issues that can be suspected as harmonics caused. The expert machine consists of 3 primary components used for trouble prognosis: the education module, the harmonic dimension module, and the diagnostic module. These modules are interrelated.

- Education Module

The education module is meant to offer the engineer with an entire route of self-paced training at the causes and effects of harmonics in addition to the fundamentals of the way a harmonics take a look at is completed. To help the scholar to recognize the arrival of distorted waveforms, a library of

waveforms became implemented into the module. Through good sized use of pictures and an interactive person interface, the module affords the scholar with immediately remarks. Review issues on the cease of numerous look at topics are designed to check the student's comprehension of the subject cloth. Moreover, the scholar has the possibility to simulate power machine conditions and check the implementation of numerous passive clear out solutions that might be very time-consuming, complex, and luxurious to simulate within the laboratory.

- Harmonic Dimension Module

The harmonic dimension module is a non-obligatory accent to the expert device to be able to provide real raw or processed time and frequency area records from the energy machine. This statistics is then available for reference whilst the professional machine is utilized to render a likely analysis of the electricity gadget problem. Regularly, this module asks the user to verify harmonic distortion through measurements. As a minimum to view the waveform with an oscilloscope, estimate general Harmonic Distortion (THD), determine the dominant harmonic via counting peaks within one 60 Hz cycle, and many others. On this manner, the measurements module can significantly assist diagnose a trouble. The harmonic dimension module includes hardware and software program which are used to capture, procedure, and store cutting-edge and voltage waveform facts. It consists of a signal conditioner and a records acquisition and analog-to-virtual (advert) conversion package hooked up in software. The signal conditioner affords the interface among the waveform signals coming from the energy system and the facts acquisition hardware. It is designed to face up to the transients associated with power gadget disturbances and faults. The board is fully controlled through computer-resident software. Most of the facts acquisition and conversion parameters are software controllable, e.g., channels to be sampled, sampling fee and length, cause method, records storage, and many others. The person interfaces with the gadget through the system software provides a schematic of the harmonic measurement module.

- Diagnostic Module

The particular application of AI (AI) utilized in the diagnostic module is named associate expert system. Associate professional system could be a rule-based AI program for play acting a task that needs experience. Professional system technology is especially suited in diagnostic systems since one in all the goals is in consolidating experience from AI system.

## 2.2 Evaluation with other algorithms

Firefly algorithm far better than genetic algorithm. The absorption coefficient and randomize firefly algorithm can be adjusted to surpass particle swarm optimization (PSO) set of rules. Many styles of play station results with numerous professionals and cons. It is more green, dependable and fast. The range index on which it get precise outcomes is modify PSO. Also the 5th harmonic is minimized algorithm however it is not minimized in the other. Removal of low-order harmonics, it use of SHEPWM method is investigated. Analysis is carried out to solve the equations. Using the Newton–Rapson approach does not recommend any ideal answer for Infeasible. Additionally the Gauss Newton technique best used in evolutionary algorithms cannot find answers but only remove low order harmonics. Analysis codes have greater complexity and more running time. Firefly and cuckoo set of rules have been used with fulfillment to compute superior switching angles for multilevel inverters with many dc assets whilst minimizing numerous harmonics. In firefly algorithm, a firefly population is positioned in random locations within the search area in which the fireflies represent a candidate answer. Using firefly set of rules optimized end result is acquired and the use of the cuckoo set of rules is efficient but stage of third, fifth, seventh, 13<sup>th</sup> rules are not efficient as predicted.

## 3. Proposed idea

To remove low order harmonics, new algorithm is proposed IWD. It is acquiring distinct finite-length steps. From its current location to its next location, the IWD speed is accrued by the number nonlinearly proportional to the inverse of the soil between the 2 locations. Moreover, the IWDs soil is accrued by removing some soil of the trail joining the 2 locations. The number of soil supplemental to the IWD is reciprocally (and nonlinearly) proportional to the time needed for the IWD to pass from its current location to the next location. This length of your time is calculated by the straightforward laws of physics for linear motion. Thus, the time taken is proportional to the speed of the IWD and reciprocally proportional to the space between the 2 locations. Another mechanism that exists within the behavior of associate degree IWD is that it prefers the ways with low soils on its beds to the ways with higher soils on its beds. To implement this behavior of path selecting, we use a uniform random distribution among the soils of the obtainable paths such the likelihood of subsequent path to settle on is inversely proportional to the soils of the obtainable ways. The lower the soil of the trail, the additional probability it's for being selected by the IWD. By applying

this algorithm for generating rule set harmonic distortion can be minimized and can give efficient formula.

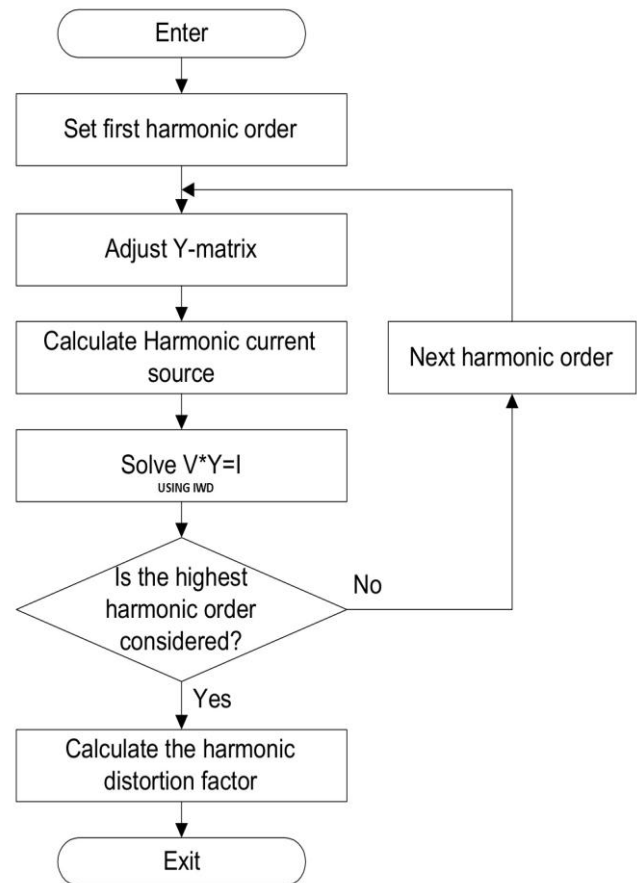
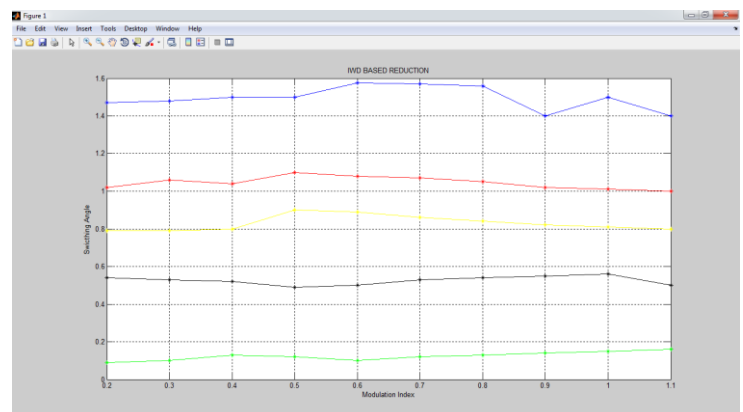

Fig. 5. Flow for harmonic minimization.



The use of Met heuristics algorithm IWD set of rules to enforce cascaded multilevel inverter reduce the harmonics. Giving numerous n input values to the herbal set of rules like

water drop algorithm in this best high-quality optimized value will taken and given to the multilevel inverter. Optimization means locating out the firing angles for minimizing losses. In this harmonics will lessen. It turned into observed that the nature-stimulated algorithm offer viable strategies for TSPs and may gain higher performance than different strategies.

#### 4. Conclusion

The selective harmonic elimination technique will accustomed eliminate the lower order harmonics and scale back the whole harmonic distortion. The IWD technique offers the lower Doctor of Theology compared to the opposite classical unvarying ways. In recent years the strategy for elimination of harmonics in structure inverters by victimization PSO (particle swarm optimization), GA(genetic algorithm ), firefly technique has been done by taking higher switch angles because the objective operate. It have a tendency to conclude by introducing IWD for lower order harmonics to eliminate, victimization the equation for Doctor of Theology because the objective operate and have given higher ends up in decrease of Doctor of Theology for up to the thirty ninth orders of harmonics. By victimization PSO, GA, firefly technique has been done by taking higher switch angles because the objective operates. It have a tendency to conclude by introducing IWD for lower order harmonics to eliminate, victimization the equation for Doctor of Theology because the objective operate and have given higher ends up in decrease of Doctor of Theology for up to the thirty ninth orders of harmonics.

#### REFERENCES

- [1] Song Q and Liu W (2009), "Control of a cascade STATCOM with star configuration under unbalanced conditions," *IEEE Trans. Power Electron.*, Vol. 24, No. 1, pp. 45-58.
- [2] Hattie N, Hasegawa K, and Adage H (2009), "A 6.6-kV transformer less motor drive using a five-level diode-clamped PWM inverter for energy savings of pumps and blowers," *IEEE Trans. Power Electron.*, Vol. 24, No. 3, pp. 796-803.
- [3] Hagiwara M, Nishimura K, and Adage H (2010), "A medium-voltage motor drive with a modular multilevel PWM inverter," *IEEE Trans. Power Electron.* Vol. 25, No. 7, pp. 1786-1799.
- [4] Siding A K, Hussein S H, Sabah M, and Gharehpetian G B (2010), "Double flying capacitor multicell converter based on modified phase-shifted pulse width modulation," *IEEE Trans. Power Electron.*, Vol. 25, No. 6, pp. 1517-1526.
- [5] Name A, Zara F, Ghost A, and Blaabjerg F (2011), "Ahybrid cascade converter topology with series-

- connected symmetrical and asymmetrical diode clamped bridge cells," *IEEE Trans. Power Electron.*, Vol. 26, No. 1, pp. 51-65.
- [6] 12. N. Prashanth, B. Kumar, J. Yadagiri, A.Dasgupta (2011),"Harmonic Minimization In Multilevel Inverters By Using PSO" *ACEEE Int. J. on Control System and Instrumentation*, Vol. 02, No. 03, October 2011
- [7] S.Saha, C.Sarkar, P.K. Saha and G.K. Panda (2013),"COMPARATIVE ANALYSIS OF SELECTIVE HARMONIC ELIMINATION OF MULTILEVEL INVERTER USING GENETIC ALGORITHM " *G.J. E.D.T.*,Vol. 2(6):48-53 (November-December, 2013) ISSN: 2319 - 7293
- [8] Faiza Nawaz, Muhammad Yaqoob, Zhou Ming, Muhammad Taha Ali(2013)." Low Order Harmonics Minimization in Multilevel Inverters using Firefly Algorithm" 978-1-4799-2522-3/13/\$31.00 ©2013 IEEE
- [9] N. Moshtaghi Yazdani, A. Yazdani.Sequerloo, M. Shariat Panahi (2013)," Reduction of Harmonic in Multilevel Inverters using FA and LAFA ALGORITHMS" *J. Basic. Appl. Sci. Res.*, 3(1s)130-135, 2013 © 2013, TextRoad Publication ISSN 2090-4304
- [10] Jinn-Chang Wu, Member, *IEEE*, Hurng-Liahng Jou(2014),"A New Hybrid Power Conditioner for Suppressing Harmonics and Neutral-Line Current in Three-Phase Four-Wire Distribution Power Systems *IEEE TRANSACTIONS ON POWER DELIVERY*, VOL. 29, NO. 4, AUGUST 2014
- [11] Saeed Anwar, Ali Elrayyah, and Yilmaz Sozer, *Senior Member(2015)*," Efficient Single-Phase Harmonics Elimination Method for Microgrid Operations" *IEEE TRANSACTIONS ON INDUSTRY APPLICATIONS*, VOL. 51, NO. 4, JULY/AUGUST 2015
- [12] S Saravanasankar, D Sivabalan1, P Elango, A John Simon Raj(2015)," ELIMINATION OF HARMONICS IN CASCADED MULTILEVEL INVERTER USING SOFT COMPUTING TECHNIQUE" ISSN 2319-5991 www.ijerst.com Special Issue, Vol. 1, No. 2, April 2015