

Seismic Performance of RC Building with X-plate and Accordion Metallic Dampers

SarikaRadhakrishnan, Mr. Sanjay Bhadke

M-Tech, str., Dept. of civil engineering TulsiramjiGaikwadPatilcollege,Maharashtra,India

Assit. Prof. M-tech str. Dept. of of civil engineering, TulsiramjiGaikwadPatilcollege,Maharashtra,India

Abstract: *The supplementary energy dissipation represents an efficient technique for the seismic protection of structural system. Metallic damper such as X-plate and AMD is among energy dissipating devices that have been using in the new generation of earthquake resisting building. In this paper, the performance of building with X-plate and AMD made of Steel are investigated to check effectiveness of damper material. For this purpose ground acceleration records, Loma Pieta is used as the disturbing ground motion for time history analysis and entire analysis is carried out by using SAP2000. The structure has been analysed without dampers and with full dampers and then after analysis, the response quantities such as maximum displacement, max interstory drift, axial force, shear force and bending moment has compared. The result obtained after the analysis shows that the response quantities are reduced significantly and it has been concluded that, these devices are very much effective to dissipate the external energy.*

Key words: :X-plate Dampers, Accordion Metallic Dampers, energy dissipating devices, Time History,

1 INTRODUCTION

Structures shows the inelastic non-linear behavior under severe cyclic loads associated with natural activities like earthquakes and winds, which imparts the external seismic energy to the them, consuming in the lateral movement of structures such movement may beresponsible for the failure or collapse of these structures, in order to prevent such a collapse it is necessary to recognize the non-linear behavior of structure and adopt an suitable mechanism to control the response of them and this is possible by dissipating the input seismic energy which imparts on them. This dissipation of energy can be achieved by providing supplementary energy dissipating devices like metallic dampers, friction dampers, viscous and viscoelastic dampers amount of energy dissipates by these dampers is

directly dependent on the material used and geometry of dampers. Amount of energy dissipates by metallic dampers can be evaluated by considering the force-displacement relationship of dampers material, such relationship known as hysteresis loop.

1.1 Seismic Retrofitting

Retrofitting is technical interventions in structural system of a building that improve the resistance to earthquake by optimizing the strength, ductility and earthquake loads. Strength of the building is generated from the structural dimensions, materials, shape, and number of structural elements, etc. . According to IS 13935:1993, Seismic retrofitting is the up gradation of the earthquake resistance up to thelevel of the present day codes by appropriate techniques.

1.2 Retrofitting Strategies for RC Buildings

There are mainly two strategies to retrofit the structure.

I. Local /member level

II. Structural Level (or Global) Retrofit Methods

There are two methods of global level retrofitting

a. Conventional methods - It is based on increasing the seismic resistance of existing structure.

b. Non-conventional method - It is based on reduction of seismic demands of the existing structure.

Passive response control systems can be classified according to the approaches employed to manage the input earthquake energy as,

(1) Seismic isolation systems.

(2) Passive energy dissipation systems.

The seismic isolation systems, illustrated in Fig. 1.2a, deflect or filter out the earthquake energy by interposing a layer with low horizontal stiffness between the structure

and the foundation. These schemes are suitable for a large class of structures that are short to medium height, and whose dominant modes are within a certain frequency range. Several building and bridges have now been installed with base isolation systems.

The passive energy dissipation systems, on the other hand, act as energy sinks and absorb some of the vibration energy so that less is available to cause deformation of structural elements. They consist of strategically placed dampers or replaceable yielding elements that link various parts of the framing system, as shown in Fig. 1.2b. Dynamic vibration absorbers also belong to this category. The reduction in the structural response is accomplished by transferring some of the structural vibration energy to auxiliary oscillators attached to the main structure. Fig. 1.2c shows a typical implementation of a tuned mass damper in a building structure.

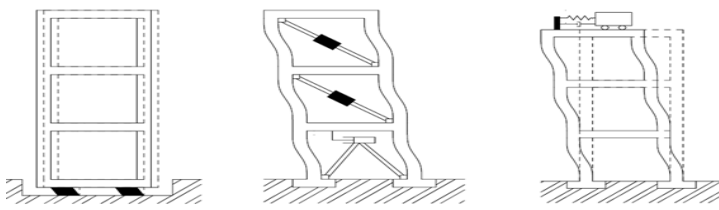

Fig.1.2a seismic Isolation systems fig.1.2b Dynamic vibration absorber fig.1.2c Implementation of a Tuned mass

1.3 Types of Seismic Energy Dissipation Devices

Yielding Metallic Dampers

One of the most effective mechanisms available for dissipation of energy, input to a structure during an earthquake, is through the inelastic deformation of metallic substances. Metallic damper utilize the deformation of metal element within the damper (energy is absorbed by metallic component that yield).

Friction Damper

Friction damper utilize the mechanism of solid bodies sliding relative to one another within damper (Energy is absorbed by the surfaces with friction between them rubbing against each other).

Viscoelastic dampers

Viscoelastic dampers typically consist of a solid viscoelastic material sandwiched between steel plates. Energy is dissipated through large shear strains in the viscoelastic material.

Viscous Dampers

The energy is dissipated through the viscous fluid dampers by moving a piston that forces a viscous fluid through orifices in the piston head. The force developed in the damper is proportional to the velocity of the moving piston.

The present study focuses on two different types of metallic dampers as a supplemental passive energy absorption device for seismic retrofitting of structure

1.4 X-plate Metallic Dampers (XPD)

An XPD is a device that is capable of sustaining many cycles of stable yielding deformation resulting in a high level of energy dissipation or damping, its energy dissipation depends primarily on relative displacement within the device and not on the relative velocities. It consist of an assembly that holds either single or multiple components of 'X' shape plates, the number of plate depends on the requisite of system to dissipates the external input seismic energy.

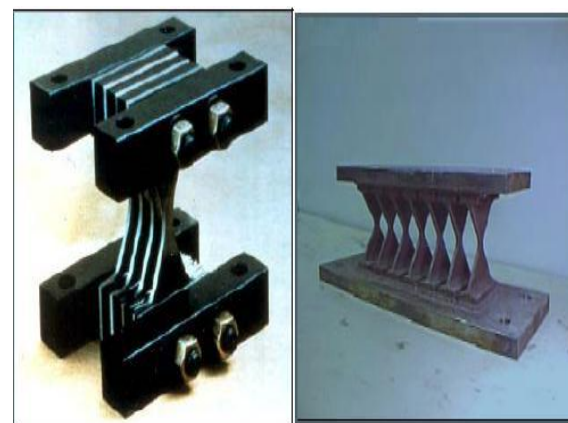

Fig.1.3a Two examples of X-plate metallic damper (XPD) (based on Whittaker et al.,)

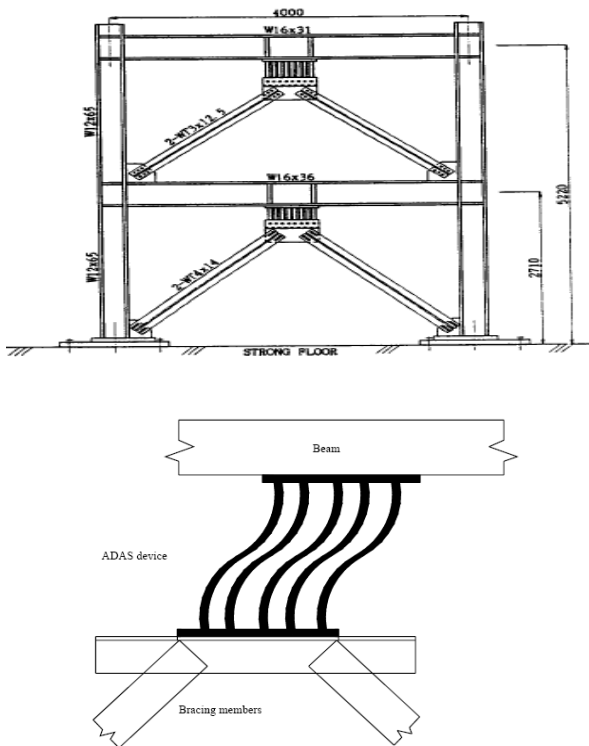

Fig.1.3b Typical metallic plate damper installation and ADAS devices deformation

1.5 Accordion Metallic Damper (AMD)

The metal tube folded along its longitudinal axis has been proved its efficiency to absorb the input energy given to them, actually it is the most common and probably the oldest shape has been using to absorb the impact energy in automobile and transportation system. Most recently, Motamedi and Nateghi (2005, 2008) has been performed analytical and experimental studied in order to study the effectiveness of accordion metallic damper (AMD) with the purpose of finding out its seismic energy absorption capacity to protect and diminish the response of structure and in their experimental and analytical study proved that the stability and the energy absorption capacity of accordion metallic damper increased by increasing the number of layers in tube.



Fig. 1.4a Accordion Metallic Damper

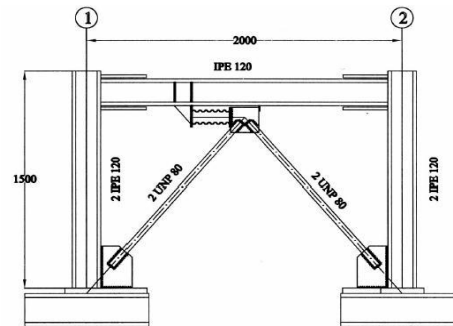

Fig.1.4b Application of AMD in seismic retrofitting of frames (based on Mehrtash MOTAMEDI, Fariborz NATEGHI-A., 2004)

1.6 Necessity and Objective of Work

1.6.1 Necessity

- The buildings have been designed according to a seismic code, but the code has been upgraded in later years.
- Buildings designed to meet the modern seismic codes, but deficiencies exist in the design or construction.
- Designers lack understanding of the seismic behavior of the structures.
- Engineering knowledge makes advances rendering insufficient the previous understanding used in their design.
- Essential buildings must be strengthened like hospitals historical monuments and architectural buildings.
- Important buildings whose service is assumed to be essential even just after an earthquake.

- g) Buildings the use of which has changed through the years.
- h) Buildings those are expanded, renovated or rebuilt.

Indian buildings built over the past three decades are deficient because of (b), (c) and (d) above. The last revision of the Indian seismic code in 1987 IS 1893 (1984) is deficient from many points of view, and engineering knowledge has advanced significantly from what was used. Also the seismic design was not practiced in most buildings being built.

1.6.2 Objectives

1. To study and understand the properties and parameters of X-plate ADAS damper and accordion metallic damper (AMD) and their application for modeling purpose in building structure.
2. To study and understand Wen’s standard hysteretic models for elasto-plastic analysis of X-plate damper and Accordion thin-walled tube under dynamic or cyclic loading which is quite prominent for the study of hysteretic dampers.
3. To develop mathematical model of building with and without XPD and AMD in SAP2000 and perform non-linear time history analysis of the building to study the seismicresponse of buildings under real earthquake ground motions.
4. To search an optimal damper location in the structure on the basis of objective function by using basic operations of genetic algorithm.
5. Investigate the response of structure with and without XPD and AMD.

2.MECHANISM OF XPD IN STRUCTURE

X-plate dampers consist of one or multiple X-shaped steel plates, each plate having a double curvature and arranged in parallel; this number of plate depends upon required amount of energy wants to be dissipates in the given system. Material used for manufacturing of X-plate may possibly be any metal which allow large deformation such as mild steel, although sometimes lead or more exotic metal alloy are employed. In order to reduce the response of structure by dissipating the input seismic energy such damper can be used with an appropriate supporting system, intrinsically in building structure combination of bracing and XPDs can be used and such a assembly known as device-brace assembly. When such system experiences the lateral forces like earthquake, high winds, etc., then input seismic energy dissipates through their flexural

yielding deformation. They can sustain many cycles of stable yielding deformation, resulting in high level of energy dissipation or damping. The aim behind the use of X-shape of damper is it will have a constant strain variation over its height, thus ensuring that yielding occur simultaneously and uniformly over the full height of the damper. XPDs allow it to behave nonlinearly but restrict behavior of the structure up to the linear elastic range.

A series of experimental tests were conducted at Babha Atomic Research Center (BARC) and IIT Bombay to study the behavior of these XPDs by Parulekar et al. (2003). Bakre et al. (2006) also studied the behavior of XPDs and observed the subsequent results (i) it exhibits smoothly nonlinear hysteretic loops under plastic deformation; (ii) it can sustain a large number of yielding reversals; (iii) there is no significant stiffness or strength degradation and (iv) it can accurately modeled by Wen’s hysteretic model or as a bilinear elasto-plastic material. A typical XPD with holding device used in the present work as shown in figure 1.

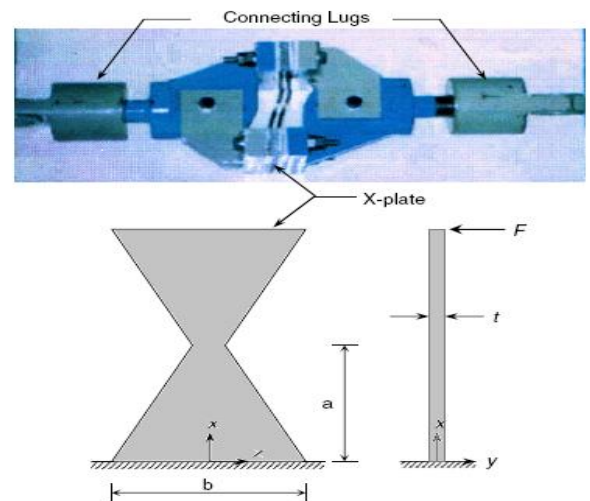

Fig. 1: X-plate damper (Bakre et. al., 2006)

Using beam theory the properties of XPD are expressed as,

$$F_y = \frac{\sigma_y b t^2}{6a} n \tag{1.1}$$

$$q = \frac{2\sigma_y a^2}{Et} \tag{1.2}$$

$$K_d = \frac{F_y}{q}$$

$$K_d = \frac{Ebt^3}{12a^3}n$$

(1.3)

Where, K_d is the initial stiffness, F_y is the yield load and q is the yield displacement of the XPD. E And σ_y are elastic modulus and yield stress of the damper material, respectively; a , b and t are height, width and thickness of the XPD as shown in figure1.

The properties of the plastically deformed XPD are expressed as

$$P = \frac{\sigma_y b}{12Ea} \left\{ \left((4y_0^2 - 3t^2)(H - E) + \frac{Ht^3}{y_0} \right) \right\} \quad (1.4)$$

Where, P is the plastic force in XPD due to given displacement d ; H is the rate of strain hardening and strain hardening and is the elastic depth given by

$$y_0 = \frac{\sigma_y a^2}{Ed} \quad (1.5)$$

It is to be noted here that using above equation, the properties of XPD, K_d , F_y , q and a could be obtained for a particular combination of a , b and t of an XPD. These properties are required in Wen's hysteretic model.

2.1 Hysteresis Loop

In earthquake engineering, hysteresis loop is a plot of forces or loads acting on the structure and its displacement due to these forces as shown in figure 4.3, these forces are due to the loading and reloading of structure. The area enclosed by this loop is a measure of the energy dissipates over a complete cycle. Amount of energy dissipates by metallic dampers can be evaluated by considering the force-displacement relationship of dampers material, such relationship known as hysteresis loop.

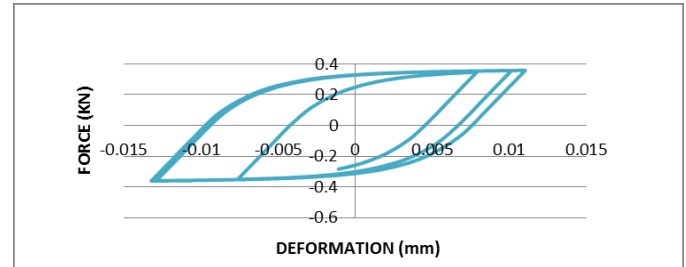

Fig. 4.3 Typical hysteresis loop of metallic damper Initially bilinear model is considered primarily to facilitate the identification of the basic design variables and relationship between them. When performing time history analyses, however, the numerical complications may arise even in simpler bi-linear models due to the sharp transitions from the inelastic to elastic states during the loading, unloading, and reloading cycles. The presence of such abrupt changes in stiffness requires the use of numerical procedures that can locate these transition points in order to avoid erroneous results. As the number of devices installed in a building structure increases and as the different phase or stiffness transition conditions for each device must be taken into account in the numerical calculations, the bilinear representation of the devices can become computationally inefficient.

2.2 Analysis and Discussion on Result

2.2.1 The data assumed for the problem to be analyzing in sap 2000

1. Columns and Beams

Table 5.1 Section Properties

Columns Designation	Size (mm)	Beams Designation	Size (mm)
C1	300 X 500	B1	230 X 500
C2	300 X 400	B2	230 X 400
C3	400 X 400		

2. Building = 7 story.
3. Slab thickness = 150 mm.
4. Live Load = 3 KN/m². (No live load at roof).
5. Floor Finish = 1 KN/m²
6. Software Used = SAP 2000.4.2.
7. Method of Analysis = Nonlinear Time History Analysis
8. Real ground motion (Time History) used

Time History	Magnitude	Source
San Fernando Earthquake - 8244 Orion BLVD."February 9, 1971, 0600 PST"	0.13g	NICEE
Parkfield Earthquake - Cholame, Shandon. "JUN 27, 1966, 20:26 PST"	0.15g	NICEE

2.2.2 Properties of Single blade XPD Assumed

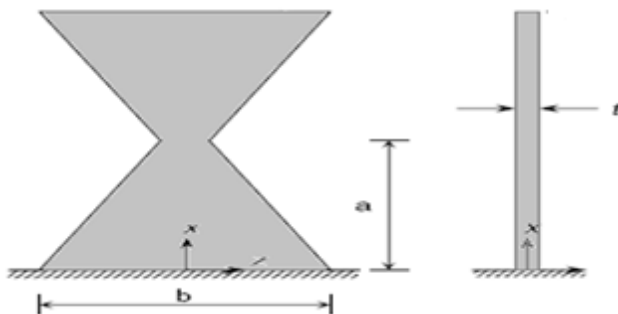

- Height of triangular portion (a) = 40 mm
 - Breadth of triangular portion (b) = 60 mm
 - Thickness of plate (t) = 4 mm
 - Number of X- Plates Used (n) = 2, 4 and 6
 - Modulus of Elasticity (E) = 1.922E+05 N/mm2
 - Yield Stress (σ_y) = 235 N/mm2
 - Strain Hardening Rate (H) = 5 E+03 N/mm2
- Calculation of Properties of XPD with one blades:

Yield Force of XPD = $F_y = \frac{\sigma_y b t^2}{6a} n = 0.94 \text{ kN}$
 Yielding Displacement of XPD = $q = 0.979 \text{ mm}$
 Effective Stiffness of XPD = $K_d = 960 \text{ kN/m}$
 Post Yield Strength Ratio = 0.0083
 (Ratio of plastic stiffness to elastic stiffness of X-plate ADAS element)

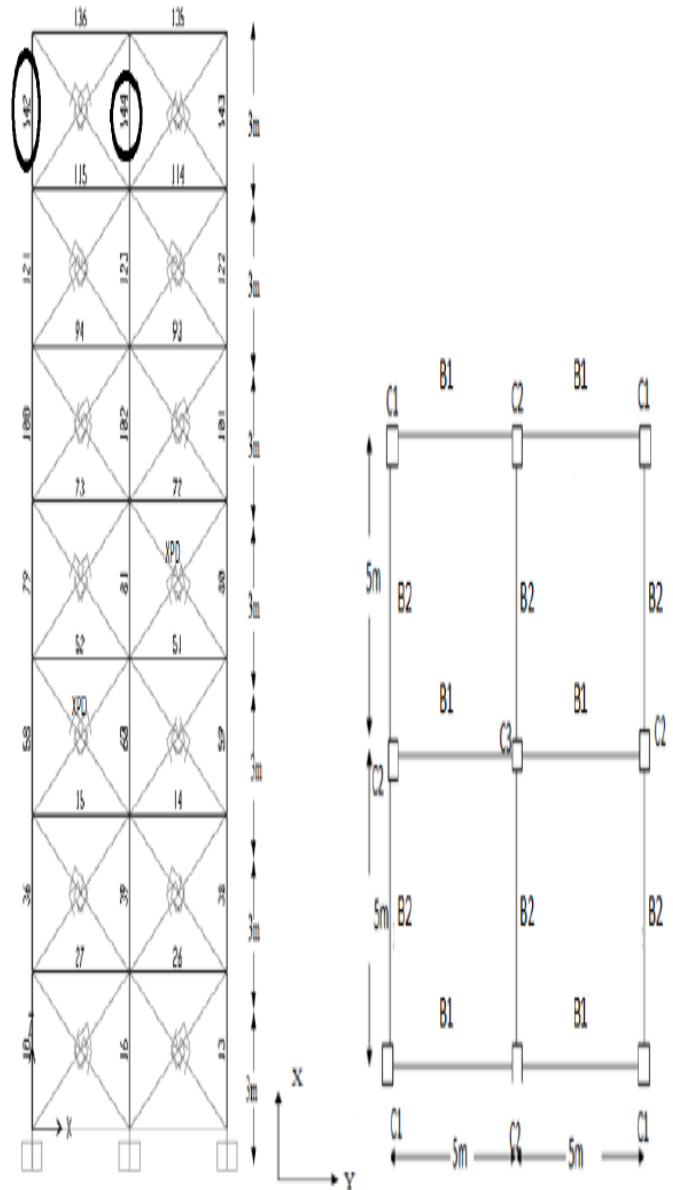

Fig. 5.1 Plan and Elevation of building with dampers

2.2.3 Result and Observations

The following result shows the comparison of responses with XPD and without XPD graphically for San Fernando and Parkfield earthquake.

a) Displacement and Inter-Story Drift Comparison

1. San Fernando Earthquake.

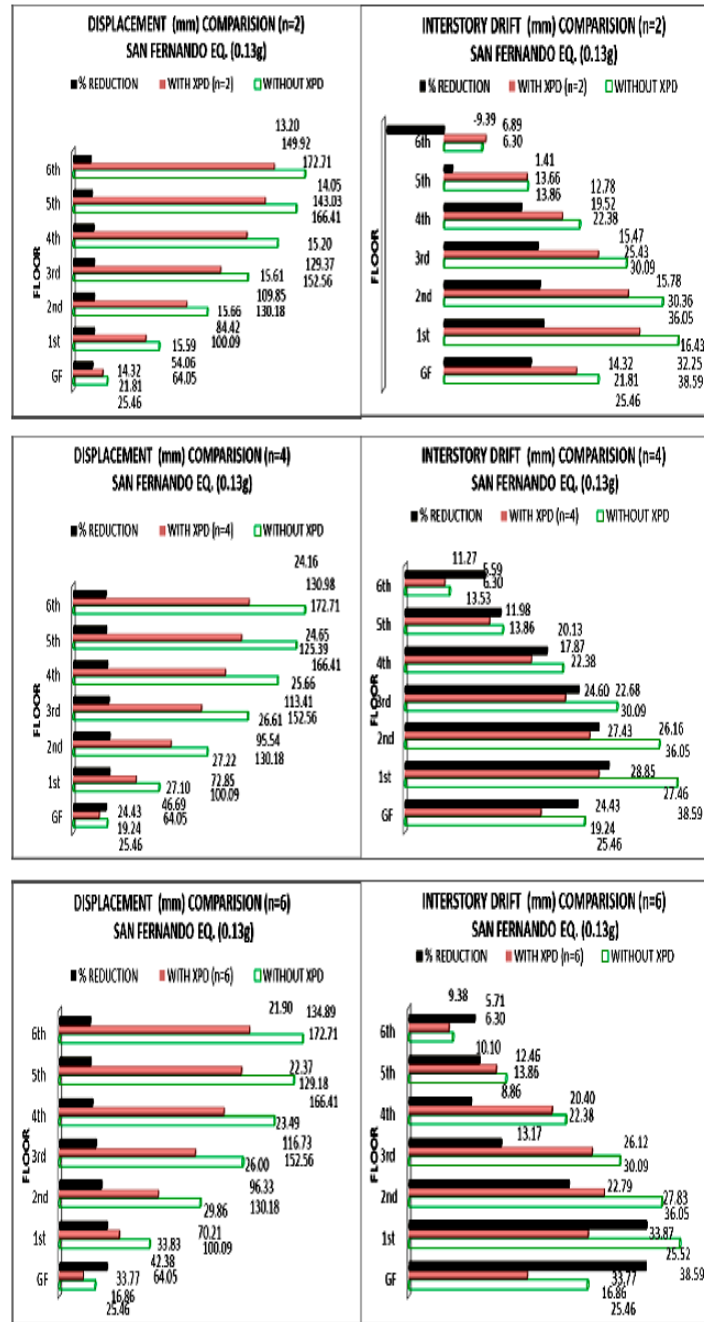

Fig. 5.2 Displacements and Inter-Story Drift Comparison for XPD (n=2, 4 and 6) at each floors, San Fernando earthquake

2. Parkfield Earthquake

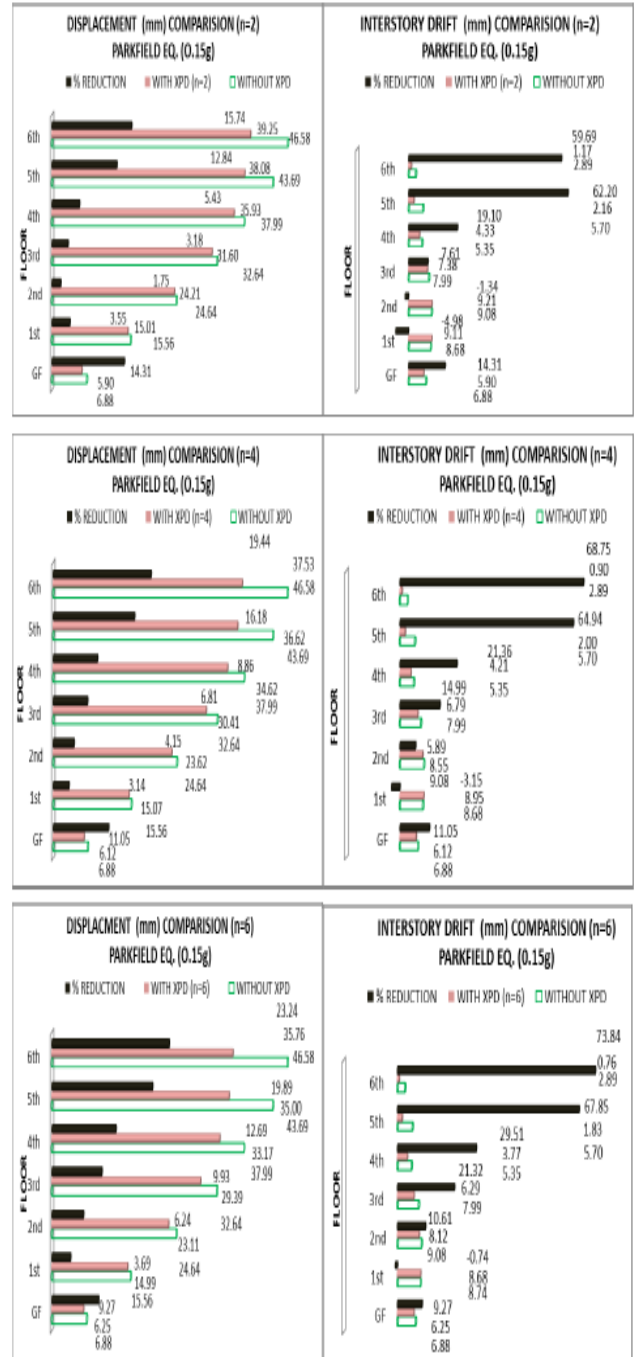

Fig. 5.3 Displacements and Inter-Story Drift Comparison for XPD (n=2, 4 and 6) at each floor of building for Parkfield Earthquake

b) Comparison of Axial Force, Shear Force and Bending Moment.

1. San Fernando Earthquake

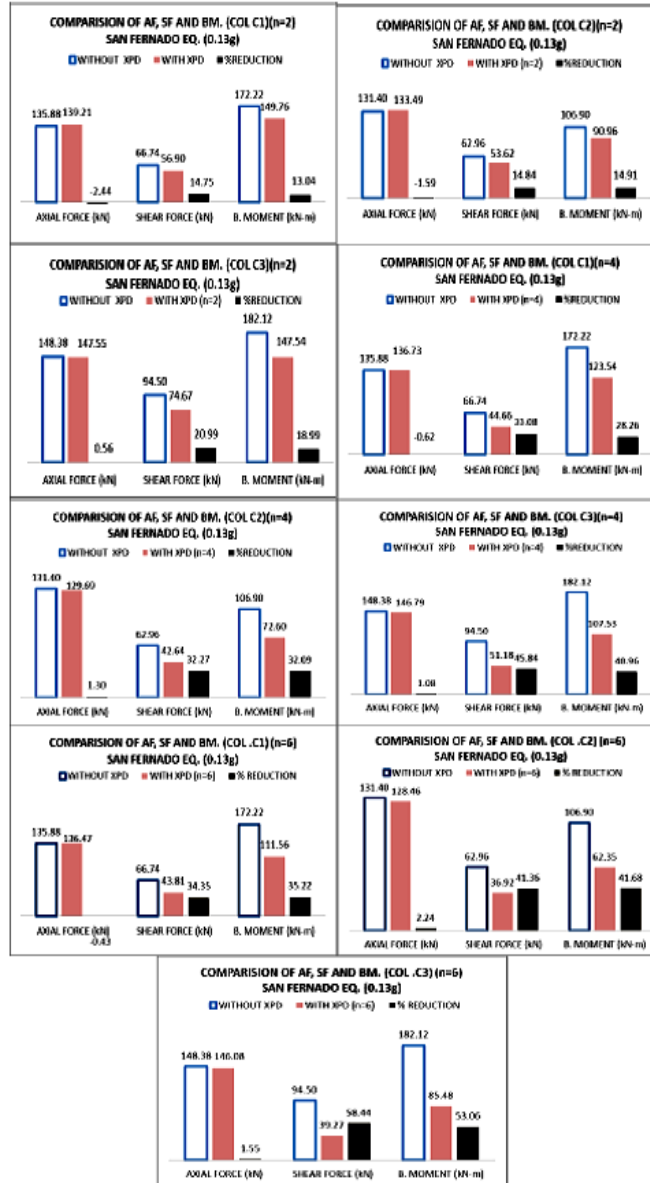

Fig. 5.4 Axial force, shear force and bending moment for XPD (n=2, 4 and 6) for column C1, C2 and C3 at top story of building for San Fernando earthquake

2. Parkfield Earthquake

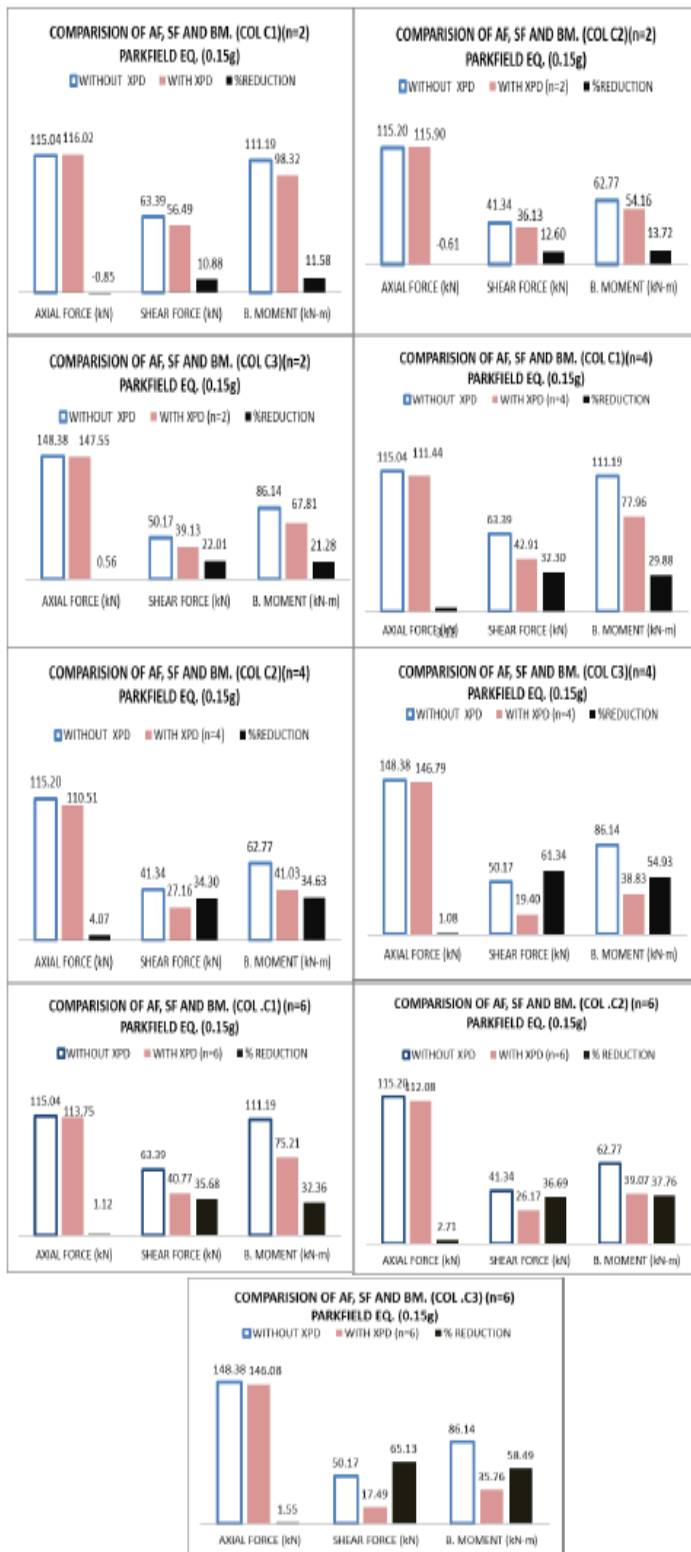

Fig. 5.5 Axial force, shear force and bending moment with XPD (n=2, 4 and 6) for column C1, C2 and C3 at top story of building for Parkfield Earthquake

c) Hysteresis Loop for XPD

1. San Fernando Earthquake 2. Parkfield Earthquake

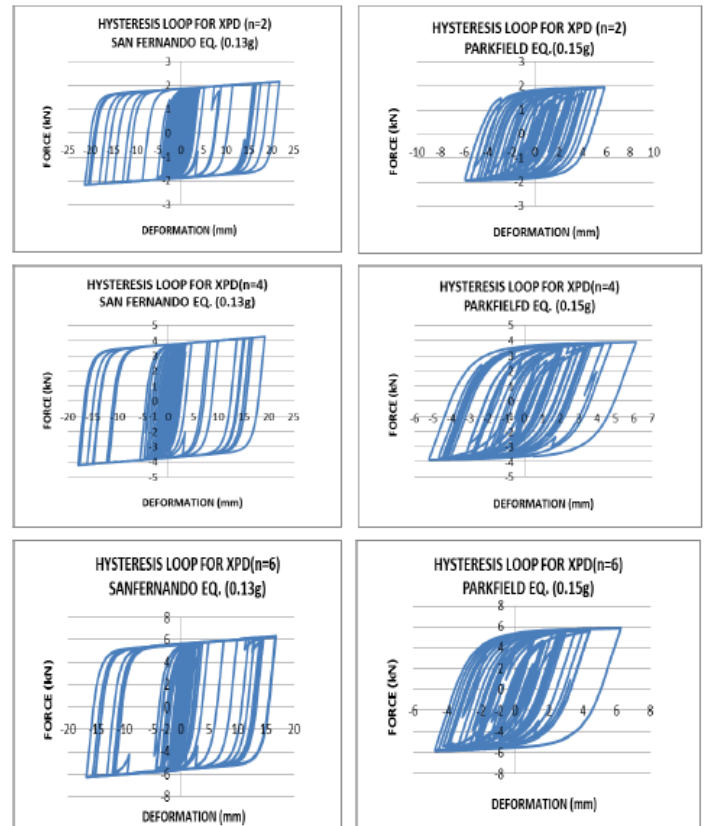

Fig. 5.6 Hysteresis loop for San Fernando earthquake

Fig. Hysteresis loop for parkfield earthquake

2.2.4 Result and Observation

a) Displacements and Inter-Storey Drift Comparison (Graphically)

1. San Fernando Earthquake

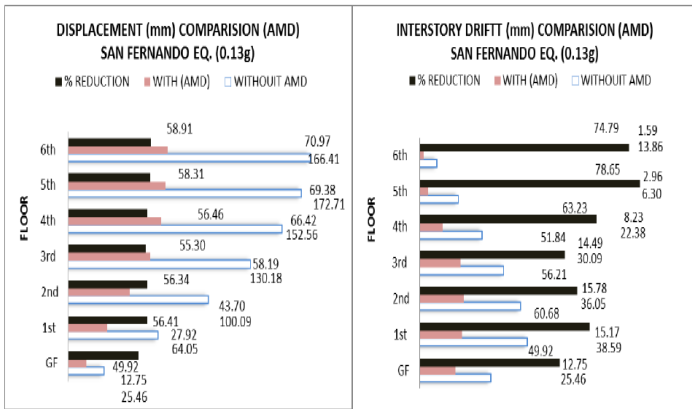

Fig. 5.9 Displacements and inter-story drift comparison for single AMD, San Fernando earthquake

2. Parkfield Earthquake

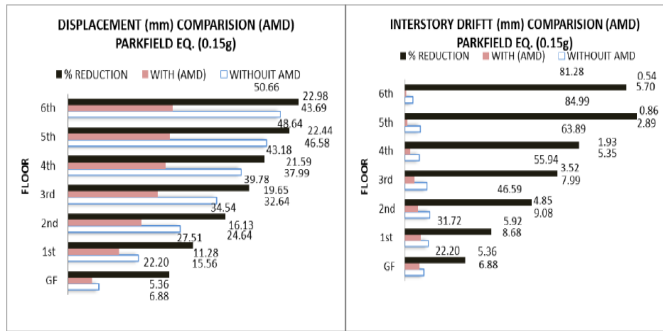

Fig. 5.10 Displacements and inter-story drift comparison for single AMD, Parkfield Eq.

b) Comparison of Axial Force, Shear Force and Bending Moment. (Graphically)

1. San Fernando Earthquake 2. Parkfield Earthquake

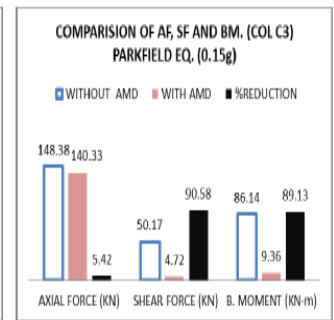
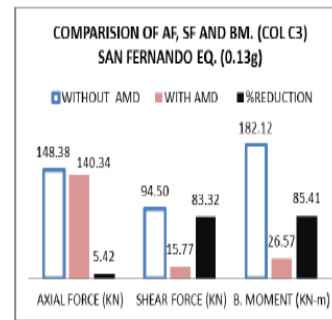
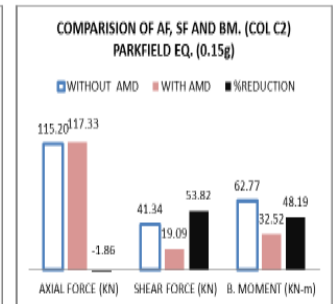
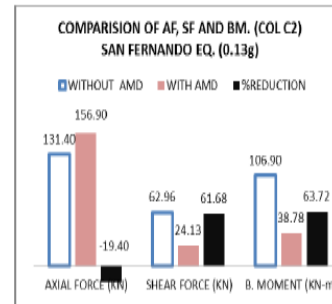
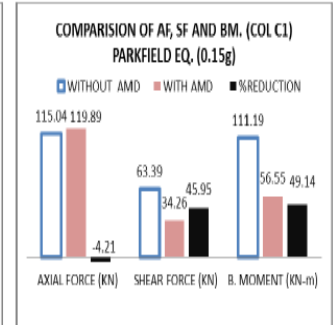
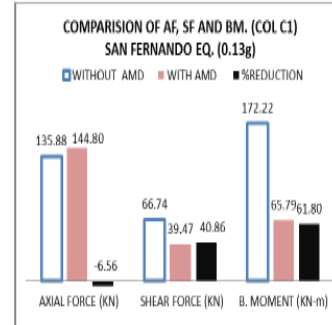

Fig. 5.11 Axial force, SF and BM for single AMD, for San Fernando Earthquake

Fig. 5.12 Axial force, SF, BM for single AMD, for Parkfield Earthquake

c) Hysteresis Loop for AMD

1. San Fernando Earthquake 2. Parkfield Earthquake

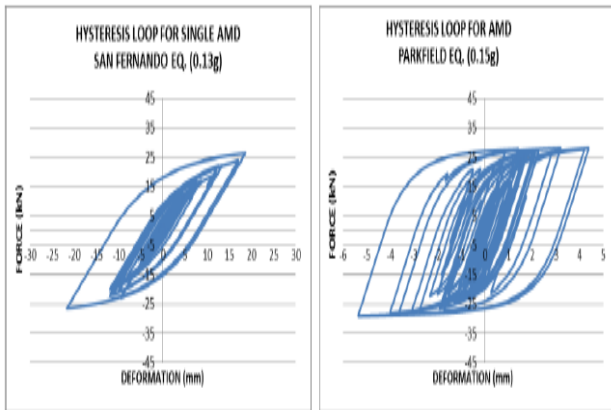

Fig 5.13 Hysteresis loop For San Fernando Earthquake
 Fig. Hysteresis loop for parkfield earthquake

3. DISSCUSION ON RESULTS

I. X-Plate Metallic Damper (XPD)

1. With increasing number of X- plates per damper, displacement and inter-story drift at each floor shows significant reduction. From fig.5.2 and fig 5.3 noted that the maximum displacement and maximum drift are reduced by about 20 – 25 % for n=6.
2. For (n=2), the axial force in all columns at top storey is increasing as compare to without XPD, but for number of X-plate more than 2, XPD shows its effectiveness to reduce the axial force as shown in fig.5.4 and fig 5.5.
3. With XPD (n=6), shear force and bending moment of all columns can reduce significantly for (n=6) as shown in fig.5.6 and fig 5.7.
4. % reduction in axial force is very small as compared to % reduction in shear force and bending moment in all columns at top storey as shown in fig.5.6 and fig 5.7.

From fig. 5.6 and 5.7, it can be observed that with increase in number of blades per damper, dissipation of energy is also increasing

2. Accordion Metallic Damper (AMD)

1. From fig. 5.9 and fig. 5.10, it is observed that with AMD, max displacement and max drift are reducing up to 50-55%.
2. From fig. 5.11 and 5.12 it is observed that axial force is increasing with AMD but shear force and bending moment is reducing significantly by an about 60%.
3. In fig. 5.13 and fig. 5.14 the hysteresis loop for AMD can be observed, it shows that, seismic energy is well dissipated by the AMD.

4. CONCLUSION

On the basis of study carried out in this project following conclusion are made.

- i. The existence of damper in the structure reduces the seismic response of the structure.
- ii. Wen’s model is a perfect model to study and understand the behaviour of the metallic damper.
- iii. It is important to find out the optimal damper location format in the building to improve its efficiency and reduce total cost of dampers to accomplish the max reduction in the response of the building.
- iv. Genetic algorithm is best optimization method to find out theoptimal damper location in the structure.
- v. Structural behaviour of building with dampers is different than the behaviour of building without dampers.

- vi. Structural behaviour of building for each damper location format is different.
- vii. There is a significant reduction in max lateral displacement and max drift in the building due to presence of dampers in the building.
- viii. There is a significant reduction in max bending moment and max shear force in the building due to presence of dampers in the building.
- ix. There is a significant reduction in base shear in the building due to presence of dampers in the building.
- x. The reduction in response quantities of the building is dependent on many factors such as properties of damper such as geometry and material and real input ground motion data selected for the analysis.
- xi. The reduction in response quantities of the building is dependent on stiffness of the dampers.
- xii. Response quantities of the building reduces with increase in the initial stiffness (yield stiffness) of damper.
- xiii. The energy dissipates by the damper is dependent on the external seismic energy imparts to the structure i.e. input ground motion data.

5. REFERENCES

- [1] Bakre S.V., Jangid R.S. and Reddy G.R. (2006), "Optimum X-plate dampers for seismic response control of piping systems", *International Journal of Pressure Vessels and Piping* 83, 672–685.
- [2] Chopra, A. K. (2001). *Dynamics of structures: Theory and applications to earthquake engineering*, 2nd Ed., Prentice Hall, Upper Saddle River, N.J.
- [3] Goldberg, D. E. (1989), "Genetic algorithms in search, optimization, and machine learning", Addison- Wesley, Reading, Mass.
- [4] Hosseini A, K., "Application of a Genetic Algorithm for Optimal Passive Control of Buildings with Metallic Dampers", *Proceedings of the 10th WSEAS International Conference on Evolutionary Computing*, pp 102 – 107.
- [5] Jain Sachin, RaiDurgesh and SahooDipti (2008), "Postyield Cyclic Buckling Criteria for Aluminum Shear Panels", *Journal of Applied Mechanics*, March 2008, Vol. 75.
- [6] Kokil A. S. and Shrikhande M., (2007), "Optimal Placement of Supplemental Dampers in Seismic", *JSEE: Fall 2007*, Vol. 9, No. 3, pp 125 – 135.
- [7] Lopez Garcia, D. (2001), "A simple method for the design of optimal damper configurations in MDOF structures." *Earthquake Spectra*, 17(3), pp. 387–398.
- [8] Michalewicz.Z. "Genetic Algorithms + Data Structures = Evolution Programs". Springer: Berlin, 1992.
- [9] Moreschi, L. (2000), "Seismic design of energy dissipation system for optimal structural performance." Ph. D. Thesis, Virginia Polytechnic Institute and State University, Blacksburg, Virginia.
- [10] Pujari, N. N., Bakre, S. V. (2011), "Optimum Placement of X-Plate Dampers for Seismic Response Control of Multistoried Buildings." *International Journal of Earth Sciences and Engineering*, ISSN 0974-5904, Volume 04, No 06 SPL, pp. 481-485.