

Analysis And Optimization of Spaced Sequential Tube-sheets

YogeshS. Idhol¹, Prof. Siddaram Biradar², Prof. Maheshwar M. Chamnalli³

¹M.E. Student Dhole Patil College of Engineering, Pune, Maharashtra²Assistant Professor Dhole Patil College of Engineering, Pune, Maharashtra³Assistant Professor Dhole Patil College of Engineering, Pune, Maharashtra

-----***-----

Abstract -Tube-sheet in any filter is a very important component as it provides a firm support to tubes in filter. Tube sheets serve multiple purposes, either they act as support for filter elements or for connecting tubes for Heat exchangers, however tube sheet design is very complex, because of its interaction with the pressure vessel and the stresses it generates. The location where the tube sheet is attached, radial expansion of the vessel is halted; this creates bending stresses in the vicinity of the tube sheet. In the existing system one or two tube-sheets are used in small size. Here in this paper new design is proposed, where 3 tube sheets spaced at equal intervals with combine vessels. The resulting stress profile will be increasingly complex. The analysis of sequential tube sheet falls under ASME sec-VIII Div-II, which recommends usage of FEA to validate the design. Objectives are to create analysis SOP (Standard Operating Procedure) in WORKBENCH, study the effect of tube sheet spacing on stress profile, To optimize the structure with Spacing distance between three space sequential tube sheets, and Thickness of the tube sheet.

Key Words:Tube-sheet, Pressure vessel, static structural analysis, ANSYS 15, ASME Code.

1. INTRODUCTION

A tube sheet is sheet, a plate, or bulkhead which is perforated with a pattern of holes designed to accept pipes or tubes. These sheets are used to support and isolate to tubes in heat exchangers, filter and boilers support elements. Depending on the application. The studies of existing system in pressure vessel one or two tube are used with small size vessel. Here in this project is totally new design that is proposed there are three tube sheets at equal intervals and combination of three pressure vessel. In this design arrangement of tube-sheets are equally spacing distance and vessel size will be large as compare to existing . design of all model by using ASME Code Section-VIII, Div-II. Three space sequential tube-sheet are final result is optimization of space, stress, and weight and as per ASME Code design will be safe for that condition and cost will be a reduces.

Here in this project deals with the analysis and optimization of spaced sequential tube-sheets in pressure vessel. A pressure vessel is a closed container designed to hold gases or liquids at a pressure substantially different from the ambient pressure. In here new design of combination of three pressure vessels and three space sequentially tube-sheets are mounted. Determination of the space sequential the tube-sheet which is widely used in the filters as main supporting elements of the filter tubes. Pressure vessel are used to store and transmit liquids, vapors, and gases under pressure in general. For analysis purpose static structural are used for model is safe for this condition and optimization of space, stress, weight and also model is safe for this condition as per ASME.

2. LITERATURE REVIEW

1. H.F. Li, C. F. Qian, & Q. B. Yuan [1] investigate the possible mechanical causes of a real tube-sheet cracking by simulate the tube sheet under different loading condition. They took three different loading conditions, namely residual expansion stress, crack face pressure and transverse pressure, and three crack growth patterns were considered. V. G. Ukadgaonker, P. A. Kale, Mrs. N. A. Agnihotri & R; Shanmuga Babu [2] works on review on analysis of tube sheets. They analysed for the different types of hole pattern in the tube sheet. Equilateral Triangular, Square, Staggered Square. Out of these patterns, the equivalent triangular arrangement is the most widely used as it is the most effective packing arrangement. Ms. Shweta A. Naik [3] Analysis results are reliable as seen in Mesh Sensitivity convergence and actual Testing. FEA Validation shows we can increase efficiency of Filter sheet by increasing number of tubes and still maintaining Factor of Safety 5. Thickness Optimization also indicates material saving and it is concluded that the optimized thickness and shape be sent for CFD analysis to check suitability. W. J. O'Donnell B. F. Langer [4] has described the method for calculating the stresses and deflection in the perforated plates with a triangular penetration pattern. The method is based partly on theory and partly on experiments. S. S. Pande, P. D. Darade, G. R. Gogate [5] The project deals with the

determination of the fatigue life of tube-sheet which is one of the major components in industrial filter vessels. The tube-sheet have to sustain the static load of the filter tubes as well as the self-weight due to gravity. In the current study a new system exerting back pressure was implemented due to which the tube-sheet was under alternating stresses causing the tube-sheet to undergo fatigue. R. D. Patil, Dr. Bimlesh Kumar [6] This paper work deals with the stress analysis of plates perforated by holes in square pitch pattern. For this consider the in plane loading condition. 2010 ASME Boiler and Pressure Vessel Codes Section- VIII Division-II. [7] ASME is one of the oldest standards-developing organizations in America. It produces approximately 600 codes and this codes used for design of pressure vessel component like as, shell, ellipsoidal head, nozzle, flange, reinforcement pad etc.

3. PROBLEM DEFINITION

Tube sheets serve multiple purposes, either they act as support for filter elements or for connecting tubes for Heat exchangers, However tube sheet design is very complex, because of its interaction with the pressure vessel and the stresses it generates. The location where the tube sheet is attached, radial expansion of the vessel is halted, this creates bending stresses in the vicinity of the tube sheet, In the new design that is proposed there are 3 tube-sheets spaced at equal intervals. The resulting stress profile will be increasingly complex.

▪ **Objectives:**

The literature survey carried out during the present course of work clearly shows that there is scope for analysis and optimization of spaced sequential tube-sheet using Finite element analysis. Hence the objectives of the present work are decided as under:

- ✓ Mechanical Design of Tube-sheet using ASME code.
- ✓ To create analysis SOP (Sequential Operating Procedure) in WB.
- ✓ To study the effect of tube sheet spacing on stress profile.
- ✓ To optimize the structure with the following criteria

- I. Spacing Distance between tube sheet
- II. Thickness of the tube sheet.

4. METHODOLOGY

Design: Instead of directly starting with modeling, first the dimensions are provided by company are to be calculated as per company design guideline (Reference no.

A-2209) and ASME code section VIII, Div-II. Calculate all necessary dimensions to design the Vessel. After verifying the all dimensions starts modeling by in Workbench and further analysis will be carried out by using Ansys software. Calculated all values by using Following ASME Code details.

Analysis: Following are the steps in ANSYS for analysis of Vessel,

- Analysis Type: Static Structural
- Engineering Data: Selection of material and material properties
- Model: Drawing the model in ANSYS Workbench
- Meshing: Discretization of Vessel Assembly
- Boundary Condition: Apply boundary condition (Pressure)
- Solve: Solving for Getting Von-mises stresses and deformation.

Experimental: For the validation of result obtained by the FEA software, experimentation is to be carried out on the actual model. Using strain gauge and Ultrasonic Test Equipment for experimental testing and then the results of this work are used for the validation of results obtained from analysis software.

5. DESIGN CALCULATION

Referring the guidelines provides by the client, the dimension of the tube-sheet were finalized. The parameters provided by client for design of tube-sheet are as follows.

Table -1: Input Parameters For Tube-sheet Design

Sr.no.	Parameter Description	Notation	Given Value
1	Internal Pressure	P	0.32 MPa
2	External Pressure	P ₀	Atmospheric
3	Process Volume	V _p	286 cu m
4	Expected Stagnant Volume	V _s	Not Specified
5	Buffer Volume Requirement	V _b	Not Specified
6	Tube Porosity Volume	T _p	70
7	Tube Length	TL	5.5 m
8	Radius of tube-sheet	r	3 m
9	Tube Diameter	T _d	0.15 m

Calculated dimensions were confirmed from the client and corrections suggested by the client were implemented in the design of tube-sheet.

The finalized dimensions of the tube-sheet were as follows:-

NTD=11000 mm

Thickness of Tube-sheet =409 mm

Ligament Efficiency = 0.1

Number of Holes on the tube-sheet=1131 Total length of vessel = 16000 mm Thickness Of Shell= 9 mm

Diameter of Nozzle = 300 mm

Thickness Of Nozzle = 12 mm No. of Nozzle= 2

Diameter of RF pad= 572 mm Thickness of RF pad=12 mm

Diameter of Flange=600 mm Thickness of Flange=12 mm

6. MODEL

First to create solid IN Workbench model by using all above calculated parameters and ASME Code Section-VIII, Div-II, and after meshing solid model more nodes are generated but capacity of system not sufficient, so create next model in surface. In surface modelling no. of nodes are decreases 40-60 % as compare to solid model, which are under the capacity to my system. Three spaced sequential tube-sheets are mounted in vessel as shown in figure.

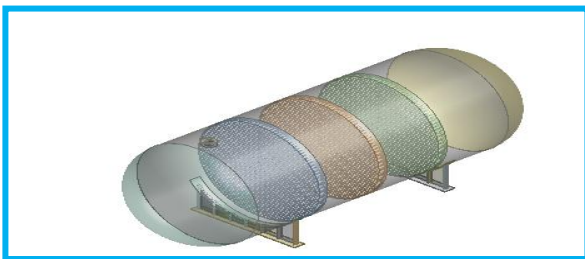

Figure-1 Solid model of pressure vessel

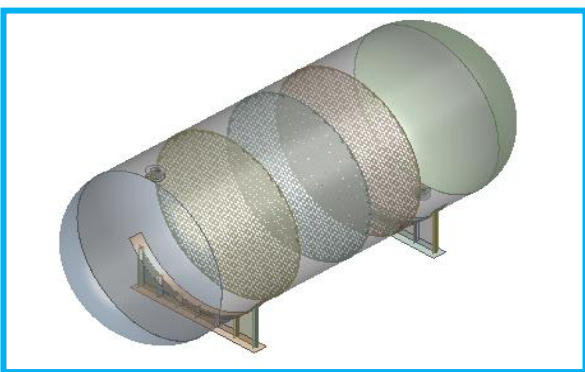

Figure-2 Surface model of pressure vessel

7. MESHING OF MODEL

Element Type-SHELL93

Table -2: Mesh control of a model (* Size varies as per number of nodes)

Parts of modal	Method	Element Size	No. of Nodes
Shell	Multiquad/tri	150	10535
Dome (2 nos.)	Multiquad/tri	150	4637
Tube-sheet (3Nos.)	All triangles	90	78282
Nozzle part(2Nos.)	Quadrilateral dominant	24	2547
Saddle	Quadrilateral dominant	40	15323
			Total =111324

8. MODAL ANALYSIS

Input Parameters

One saddle support is fixed and check the contact between face to face contacts, edge to edge contacts, edge to face contacts are properly detected or not.

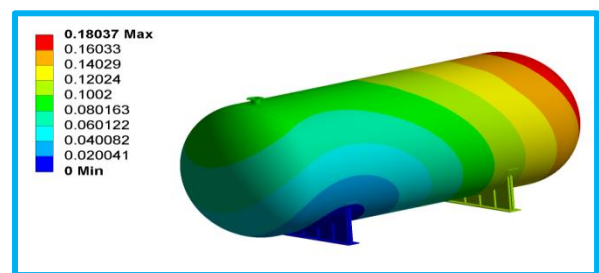

Figure-3 Maximum deformation- 0.18 mm

Above results shows maximum deformation is 0.18 mm and Frequency is 2.7476 Hz, so frequency is more than zero shows the all the contacts are properly detected.

9. STATIC STRUCTURAL ANALYSIS

Input Parameters

1. Both saddle supports are fixed.
2. Gravity acting downward

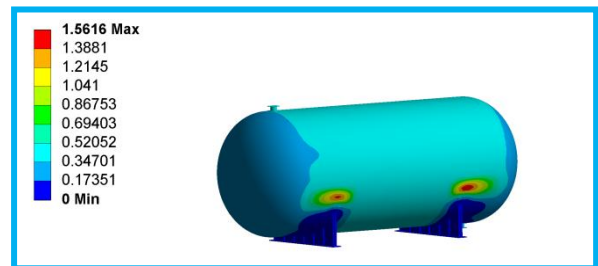

Figure-4 Maximum deformation-1.5616 mm

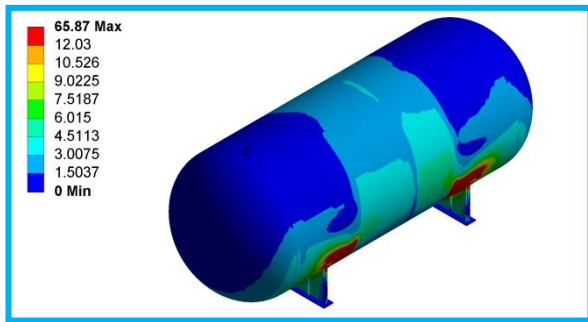

Figure-5 Maximum stress=65.87 MPa

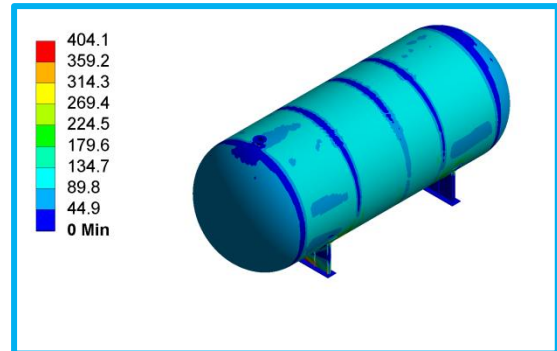

Figure-8 Maximum stress= 404.1 MPa

Above gravity results shows maximum deformation is 1.5616 mm and maximum stress is 65.87 Mpa.at these vessel is safe for self-weight.

10. STATIC STRUCTURAL ANALYSIS

Case-01: Input Parameters

1. Apply Internal Pressure=0.32
2. One saddle support is fixed and on second saddle Apply displacement.

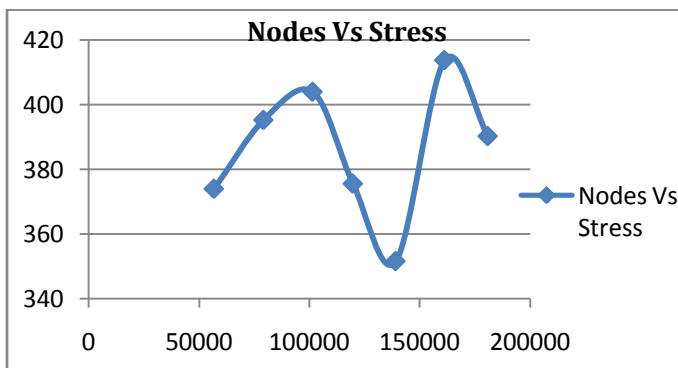

Figure-6 Thickness Vs Stress

Figure Shows the Graph of Nodes Vs Stress in which two peak points of Stress are seen at 101552 and 161245. The difference between them is less. Selecting the first peak point as the numbers of nodes are less and therefore the time required to solve the analysis is less compared to next peak point's number of nodes. Here the number of nodes for further analysis cases are finalized which are 101552 nodes.

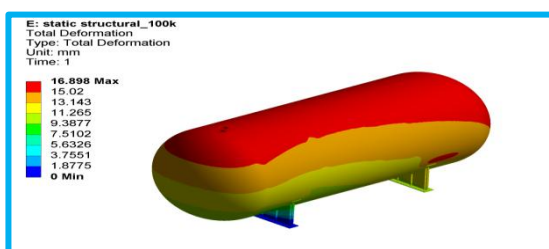

Figure-7 Maximum deformation= 16.89 mm

Case-02: Input Parameters

Applying same boundary condition of case-01 and with Standard Earth Gravity

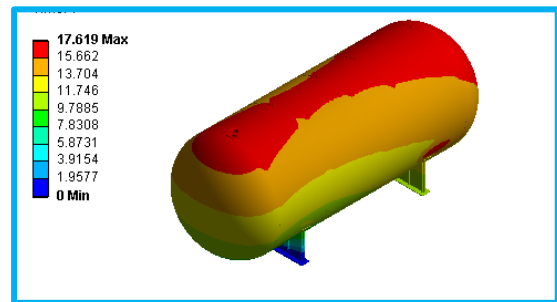

Figure-9 Maximum deformation= 17.61 mm

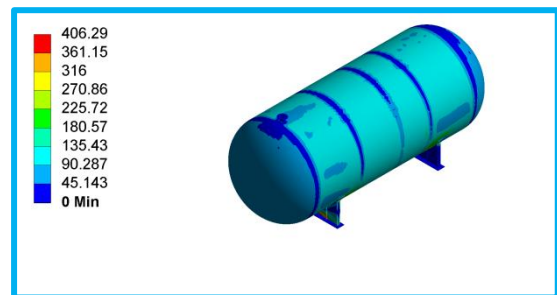

Figure-10 Maximum stress=406.29 MPa

Above results of Case-01 and Case-02 shows the model is not safe because stress is more than maximum allowable limit ,so need of optimization of tube-sheet for reducing stress and weight.

Case 03: Solid Tube-sheet Optimization at pressure 0.32 MPa

Input Parameters

1. Fixed support
2. Apply pressure = 0.32 MPa

Table-3: Maximum Stress & Maximum Deformation results for Different Thickness of tube-sheet

Sr. NO.	Thickness (mm)	Stress (MPa)	Deformation (mm)
1	409	38.48	17.441
2	400	40.54	17.045
3	350	53.35	16.898
4	280	84.71	16.175
5	240	116.75	16.648
6	230	127.56	16.5

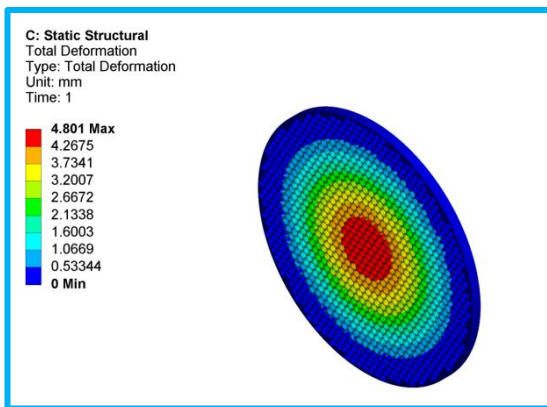

Figure-11 Maximum deformation= 4.801 mm

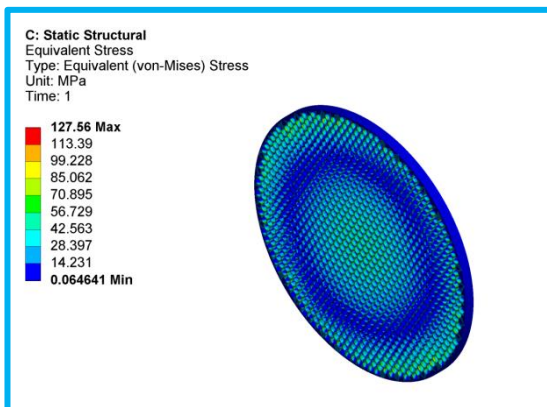

Figure-12 Maximum deformation= 4.801 mm

Tube-sheet is analyzed for pressure of 0.32MPa, decreasing the tube-sheet thickness from 409 mm to obtained the optimum thickness. The stress at 230mm thickness of tube-sheet is 127.56 MPa which is nearest and less than allowable stress. So the final Optimum thickness for tube-sheet at pressure of 0.32 MPa is decided at 230mm.

Case 04: Tube-sheet Optimization with Point Load and pressure of 0.01MPa

Optimized 230 mm thickness of tube-sheet with applying Gravity, point mass 2.5 kg of every tube on mid-point of tube length and pressure on tube-sheet 0.01 MPa ,various analysis are as follows.

No. Tube-Sheet = 1 Total number of Tubes = 1131
Mass of each tube = 2.5 kg

Total mass of all tubes on the tube-sheet =2.5*1131 = 2827.5 kg

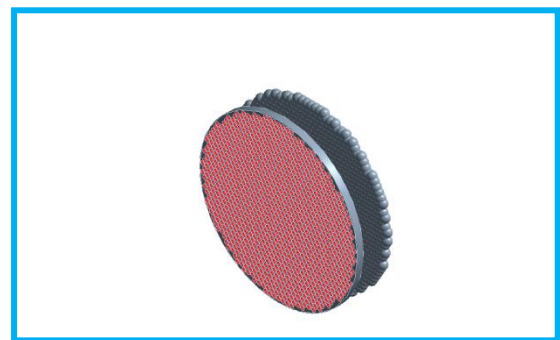

Figure-13 point mass of 2.5 kg of each tube at its C.G.

Table-4: Maximum Stress & Maximum Deformation results for Different Thickness of tube-sheet with mass of each tube at its C.G.

Sr. NO.	Thickness (mm)	Stress (MPa)	Deformation(mm)
1	230	4.6618	0.1501
2	200	5.8856	0.2268
3	180	7.3474	0.3094
4	160	9.0768	0.4379
5	140	11.612	0.6495
6	120	15.671	1.0215
7	100	22.37	1.7403
8	80	34.559	3.322
9	60	66.195	7.751

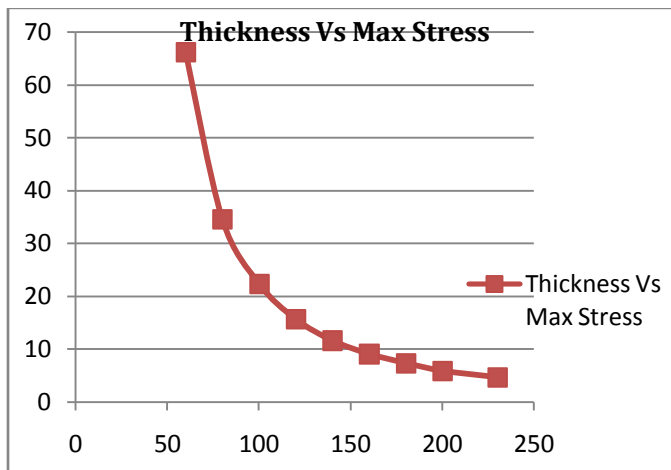

Figure-14 Thickness Vs Stress

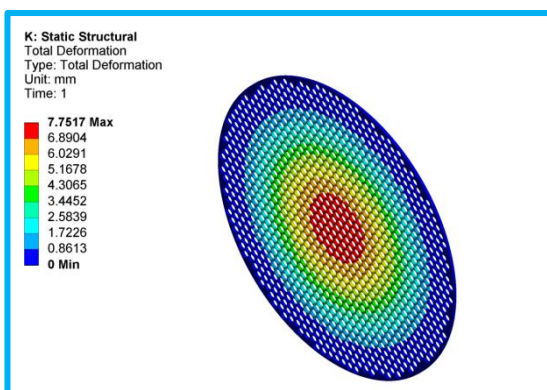

Figure-15 Deformation = 7.7517 mm

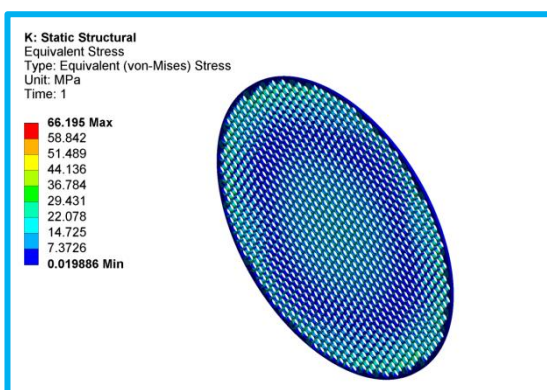

Figure-16 Maximum stress = 66.195 MPa

Tube-sheet analysis with Point Load 2.5 kg of each tube and pressure of 0.01MPa is done with decreasing the tube-sheet thickness to obtained the optimum thickness. The stress at 60mm thickness of tube-sheet is 66.195MPa which is nearest and less than allowable stress. So the final Optimum thickness for tube-sheet with Point Load of each tube and Pressure of 0.01MPa is decided at 60mm.

Case 04: Complete Vessel Analysis considering all tubes masses, pressure on tube-sheets 0.01MPa and internal Pressure on all other components as 0.32 MPa

Total number of Tubes = 1131

Total number of tube sheets = 3

Mass of each tube = 2.5 kg

Total mass of all tubes on the three tube sheets = $2.5 \times 1131 \times 3 = 8482.5$ kg



Figure-17: showing all point masses on all tube-sheets

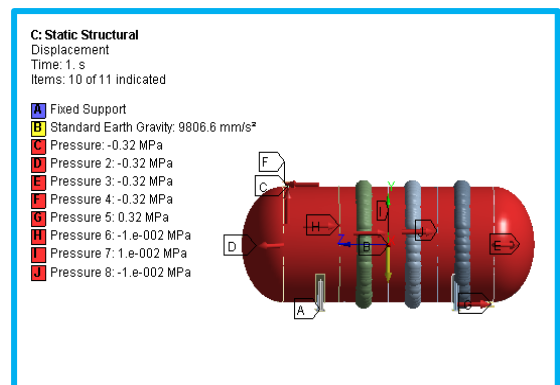

Figure-18: showing Boundary Condition and all point masses on all tube-sheets

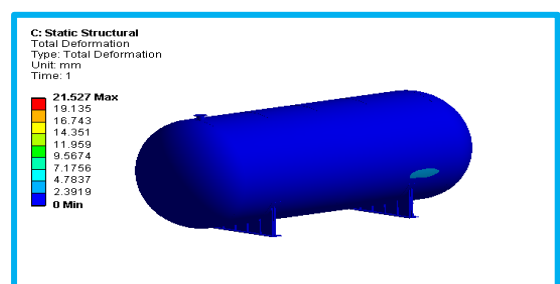

Figure-19: Deformation = 21.52 mm

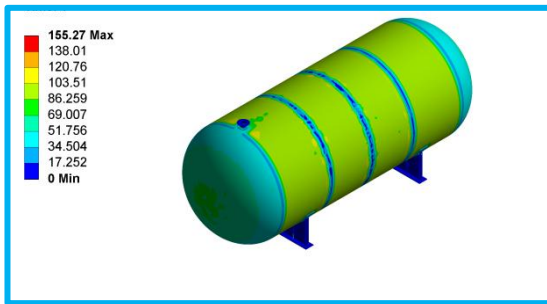

Figure-20: Stress=155.27 MPa

In the above analysis case the stress is exceeding but is near the allowable stress. So to reduce the stress one more saddle support is suggested.

Case 05: Complete Vessel Analysis considering all tubes masses, pressure on tube-sheets 0.01MPa and internal Pressure on all other components as 0.32 MPa with 3 saddle supports.

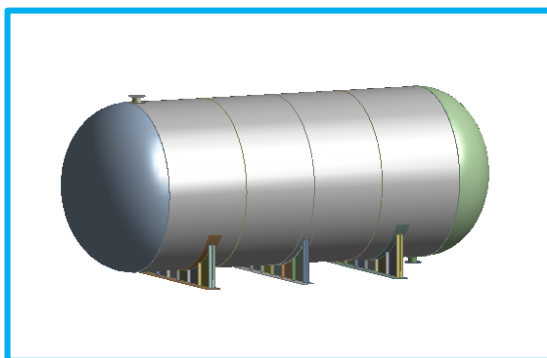

Figure-21: pressure vessel with 3 saddle supports

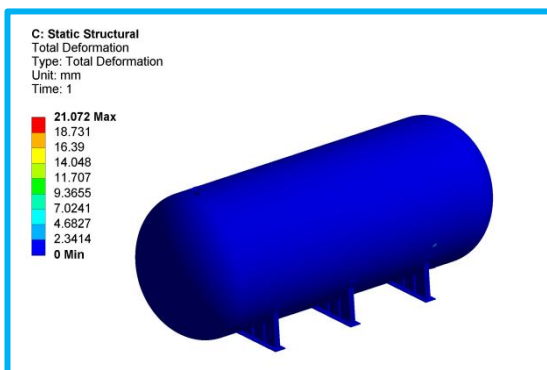

Figure-22: Deformation=21.072mm

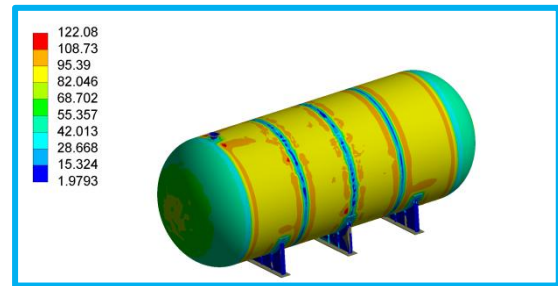

Figure-23: Stress=122.08 MPa

Stress Result for Complete Vessel Analysis considering all tubes masses, pressure on tube-sheets 0.01MPa and internal Pressure on all other components as 0.32 MPa with 3 saddle supports stress is 122.08MPa which is within the limit of allowable stress.

Now the complete Pressure Vessel considering all the boundary conditions and pressure conditions is Safe, as the stress is within the allowable limit of 138MPa

11. CONCLUSION

1. The project is basically focused on an Analysis and optimization of space sequential tube-sheet in pressure vessel. Design of pressure vessel are done by ASME Code Section-8. Div-2.

2. The Analysis of pressure vessel model was done in ANSYS 15.0 workbench. The results were supported with an experimental validation for verifying the actual deformation and FEA results. Following are concluding remarks based on the analysis performed on vessel.

3. Firstly analysis of pressure vessel model is done to develop the standard operating procedure. from the comparison of results at different mesh size.it is concluded that variation in results is within acceptable limit, hence approximately 100000 nodes mesh size is fixed for further analysis.in that maximum stress is 404.1MPa and deformation is 16.89 mm.

4. Tube-sheet optimization including point mass weight of 2.5 kg of each tube for reducing weight and material, 60 mm of tube-sheet is finalized.Optimizationresults shows 71% weight reduced of Tube-sheets.

5. Stress Result for Complete Vessel Analysis considering all tubes masses, pressure on tube-sheets 0.01MPa and internal Pressure on all other components as 0.32 MPa with 3 saddle supports is 122.08MPa which is within the limit of allowable stress (138MPa)

6. Experimental test shows that no leakage and damage in vessel.

Above all the conclusion shows the optimization of stress, space, and optimization of tube-sheets is reducing the

weight and material is done. for this condition model is safe as per ASME Section-VIII, Div-II.

FEA results and Experimental results are in close resemblance and proved that FEA analysis is correct and is validated by experimental deformation results. Manufactured tested values is 9.41mm. % error between FEA and experimental result's is 17% which is less than the allowable error (20%) in FEA for large pressure vessel. hence our FEA results are reliable. No damaged is detected by using ultrasonic testing machine. Finalized vessel satisfies ASME Criteria and this has been validated through FEA.

12. References

- [1].H.F. Li,Qian, C. F. & Yuan,Q. B. (2010).Cracking simulation of a tube-sheet under different loadings. Theoretical and Applied Fracture Mechanics,54(1),27-36.
- [2].V. G. Ukadgaonker, P. A. Kale, Mrs. N. A. Agnihotri & R; Shanmuga Babu (1995). Review of analysis of tube sheets. Int J. Pres. Ves. & Piping 61(1996) 219-297.
- [3].Sweta Naik Thickness and shape optimization of Filter Tube-sheet by Non Linear FEA' [Journal]. - [s.l.] : Global Journals Inc. (USA), 2013. - 1 : Vol. 13.
- [4].W. J. O'Donnell B. F. Langer 'Design of Perforated Plates' [Journal]. - [s.l.] : ASME, 1962. - Vol. 84.
- [5].S. S. Pande, P. D. Darade, G. R. Gogate 'TRANSIENT ANALYSIS AND FATIGUE LIFE PREDICTION OF TUBESHEET' IJRET: International Journal of Research in Engineering and Technology eISSN: 2319-1163 | pISSN: 2321-7308.
- [6].R. D. Patil, Dr. Bimlesh Kumar. Stress Analysis of Perforated Tube Sheet Used for Pressure Vessel having Square Pitch Hole Pattern. IJIRSET, Vol. 4, Issue 1, January 2015, ISSN (Online): 2319 – 8753.
- [7].2010 ASME Boiler and Pressure Vessel Codes Section-VIII Division-II.
- [8].Shugen Xu, Yanling Zhao. Using FEM to determine the thermo-mechanical stress in tube to tube-sheet joint for the SCC failure analysis. Engineering Failure Analysis 34 (2013) 24–34.
- [9].Liu Minshan 'Stress analysis of Ω -tube-sheet in waste heat boiler' [Journal]. - [s.l.] : Journal of Pressure Equipment and Systems, 2006. 2010.
- [10].Kotcherla Sriharsha, Venkata Ramesh Mamilla and M.V. Mallikarjun. Strength Analysis of Tube to Tube Sheet Joint in Shell and Tube Heat Exchanger.ISSN: Volume 1, Issue 4, October 2012: 2278 – 7798.
- [11].Ravivarma.R, Azhagiri. Pon.Finite Element Analysis of a Tube sheet with considering effective geometry properties through design methodology validated by Experiment. ISSN (e): Vol, 04, Issue, 4, April – 2014, 2250 – 3005.
- [12].Dr. Enrique Gomez, Roberto Ruiz, Robert M. Wilson. ASME Section III Stress Analysis of a Heat Exchanger tube-sheet with a mis-drilled hole and irregular or thin ligaments. PVPC, July 14-18, PVP 2013:97075.
- [13].V.V. Mahajan, S. B. Umarji, Joshi's Process Equipment Design Data Book , 5th Edition , Design Of Saddle Supports,Page No.356-360.
- [14].ASME Boiler and Pressure Vessel Codes Section VIII, Division I.
- [15].ASME Boiler and Pressure Vessel Codes Section-II, Part-D.