

A Logic gate based Double Talk Detector for Acoustic Echo Cancellation

Harkirat Kaur¹, Rupinder Kaur²

¹Student, Department of ECE, Punjabi University, Patiala, Punjab

²Assistant Professor, Department of ECE, Punjabi University, Patiala, Punjab

Abstract –The occurrence of echo is one of the major problems faced by hands free telephone systems. Acoustic echo cancellers (AEC) are used to improve the quality of speech by removing echo. Adaptive filters make it possible to cancel the echo after estimating it. Double talk occurs when both far and near speakers are activating simultaneously, results into the divergence of adaptive filter. Double talk detectors based on decision parameter calculation and comparing with threshold are used to freeze the filter adaptation during double talk periods. These detectors miss some double talks and increase the residual error. In this paper, we present a new way of detecting double talk using logic AND gate so that missed detection rate decreases and acoustic echo canceller performance improves.

Key Words:AEC, Double talk detection, constant threshold based DTD, logic gate based DTD, simulations, ERLE, MSE, Probability of missed detection

1. INTRODUCTION

Acoustic echo may occur whenever a loudspeaker and microphone are placed close to each other in the hands free telephone system. The origin of acoustic echo is multiple reflections of the loudspeaker sound due to various objects in the room. [2] The voice of a person speaking on far side is generated by loudspeaker on near side. The reflection of that sound is captured by microphone in the room, is transmitted to the far side and person on the far side will hear echo. Therefore, the occurrence of echo may result into the loss of some information and degrades speech quality.

Acoustic Echo Cancellers are used to remove the echo signal from microphone signal. Adaptive filters are used for this purpose. These are the filters with adjustable coefficients which aim at minimizing the function of difference between desired signal and filter output. [18] The problem arises when far end person and near end person speaks simultaneously. This results into double talk situation in acoustic echo cancellers.

Fig.1 shows a basic acoustic echo canceller which consists of an adaptive filter and a double talk detector. AEC works on the principle of estimating the echo and subtracting it from true echo. [8] Input signal is a far

end signal which is passed through echo path and generates echo signal. Echo signal adds up with near end signal along with some background noise to produce a received microphone signal. On the other hand, far end signal is also given to an adaptive filter and signal is convolved with weight matrix to produce estimated echo or filter output. The estimated echo is subtracted from the microphone signal giving error signal which is fed back to adaptive filter for coefficient adaptation. In the ideal case, error signal will be equal to near end signal.

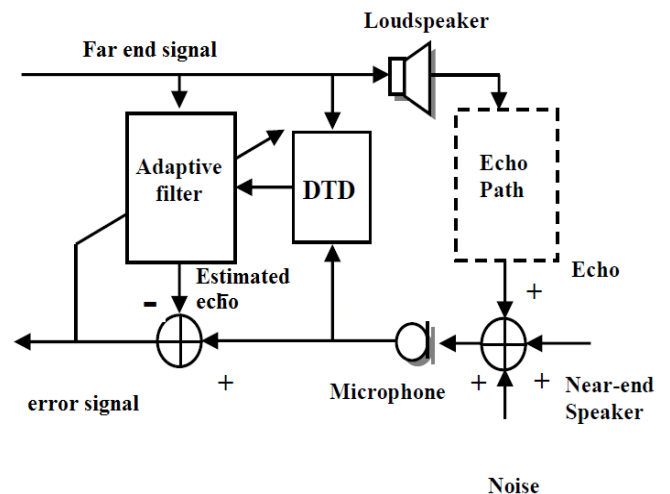

Fig-1: DTD based Acoustic echo canceller

The problem of dual talk is handled by double talk detectors which senses the double talk and stops the adaptive filter coefficient adaptation so that filter may not move away from the optimal solution. Various methods have been used for handling double talk. These methods aim at determining a decision parameter and comparing this parameter with a constant threshold value. A variance impulse response method is used in [5], in which results are achieved at the cost of high complexity. A cross correlation method is used for the estimation of decision parameter in [9],[10], which results into low Mean Square Error and low probability of successful detection.

Various adaptive algorithms Least Mean Square (LMS) [5], Normalized LMS [4], Variable step LMS [9] can be used for coefficient updating. In this paper, Variable Step Size Least Mean Square algorithm is used for adjusting filter parameters because it shows high value of Echo Return Loss Enhancement. In VSLMS, Step size is varied with

respect to error signal. [9] Weight adaptation equation is given as:

$$w(n + 1) = w(n) + \mu(n)e(n)x(n)$$

Variable step size is given as:

$$\mu(n + 1) = \gamma\mu(n) + \sigma e^2(n)$$

Where $0 < \gamma < 1$ and $\sigma > 1$

2. DTD USING CONSTANT THRESHOLD

The steps followed by constant threshold based double talk detector are as follows:

Step-1: A decision parameter is calculated using far end signal, error signal or received signal. [9] A cross correlation vector between far end signal and received signal is used for this purpose which is given as:

$$P_{dx} = \frac{E\{x(n)d(n)\}}{\sqrt{E\{x^2(n)\}E\{d^2(n)\}}} = \frac{R_{dx}}{\sigma_x\sigma_d}$$

Where $x(n)$ is a far end signal and $d(n)$ is received signal. P_{dx} is a vector and R_{dx} is cross correlation between far end signal and received signal. σ_x indicates power of far end signal and σ_d indicates power of received signal. Decision parameter is

$$p(n) = |P_{dx}| = \max |P_{dx}^i| ,$$

Where $i = 0, 1, \dots, L-1$. L is the length of adaptive filter

Step-2: A constant value is set which is compared with the decision parameter.

Step-3: If the parameter value is smaller than constant threshold, it indicates double talk is present and filter adaptation is stopped to prevent it from diverging.

Step-4: If the parameter value is greater than constant value, it indicates double talk is not present and adaptive filter coefficient updating continues.

3. DTD USING LOGIC GATE

The steps followed by gate based double talk detector are as follows:

Step-1: Far end speech activity detector for the detection of far end signal is used which gives binary data as output. Far End Detection (FED) is calculated by comparing the power of far end signal with some threshold (Far_th).

Step-2: Near end speech activity detector for the detection of near end signal is used which gives binary data. Near End Detection (NED) is also calculated by comparing its power with threshold (near_th).

Step-3: FED and NED signals are given to a logic AND gate which performs as follows to give double talk detection.

Table-1: Double Talk Detection using AND gate

FED	NED	DTD
0	0	0
0	1	0
1	0	0
1	1	1

Step-4: If DTD or AND gate binary output is greater than 0 i.e. 1 double talk is present and filter adaptation is stopped otherwise continues.

4. SIMULATION AND RESULTS

MATLAB R2013a platform is used for the simulations. Far end and near end signal are recorded at sampling rate of 8000Hz. Signals are loaded into matlab with .wav extension. The procedure of echo cancellation is followed using Variable step LMS algorithm. Signal to Noise ratio is set to 40dB. Total length of the signals is 88000 samples. The proposed method is compared with cross correlation based DTD with constant threshold value of 520. The parameters used in simulation are shown as:

Table-2: Parameters used in simulation

Parameter	Value	Parameter	Value
N	88000	T(constant threshold)	520
L	1000	SNR(dB)	40
Fs	8000	Near_th	0.0001
γ	0.025	Far_th	0.0001
σ	0.97		

Mean Square Error is calculated as the mean of the square of error signal. It must be minimized for improved performance.

Echo Return Loss Enhancement (ERLE) is a measure of amount of echo cancelled after cancellation of echo.

$$ERLE = 10 \log_{10} \frac{\text{Power of received signal}}{\text{Power of error signal}}$$

$$= 10 \log_{10} \frac{P_d(n)}{P_e(n)}$$

Detector performance is measured in terms of probability of detections as follows:

Probability of successful detection (Pd): It indicates the probability of detecting double talks when they actually exist.

Probability of missed detection (Pm): It indicates the probability of declaring detection absence when double talk is present.

$$P_m = 1 - \frac{\sum(\text{FED}).(\text{NED}).(\text{DTD})}{\sum(\text{FED}).(\text{NED})}$$

Probability of false alarm(Pf): It indicates the probability of declaring double talk presence when double talk is absent.

$$P_f = \frac{\sum(\text{FED})(\text{DTD})}{\text{length of far end speech}}$$

The calculation of these probabilities depends on the speech activity detector outputs. [8] Probability of missed detection is plotted as a function of near to far end ratio (NFR). Six different sentences are chosen as near end signals and different levels of NFR are generated corresponding to that signals. MATLAB simulations of results are shown as under:

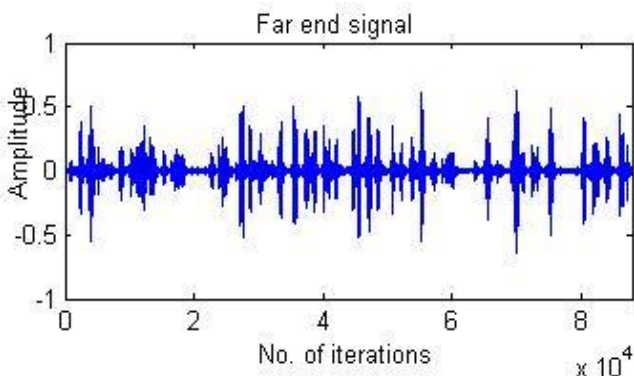

Fig-2.simulation result of far end speech signal

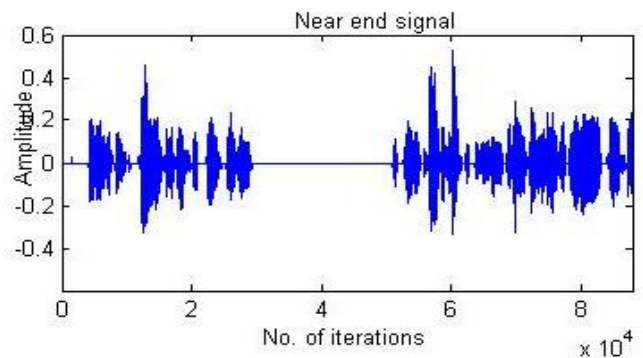

Fig-3.simulation result of near end speech signal

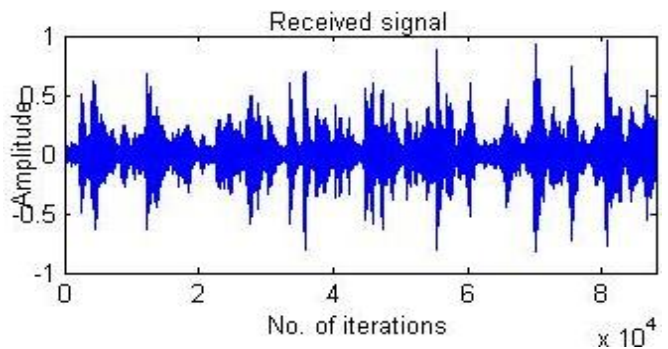

Fig-4.simulation result of Received microphone signal

4.1 Results for constant threshold based DTD

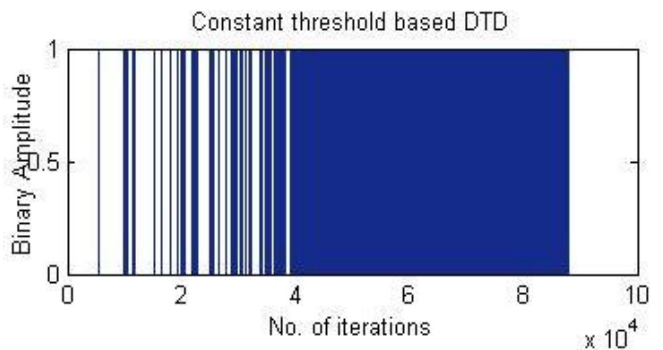

Fig-5.Simulation result of Double Talk Detection

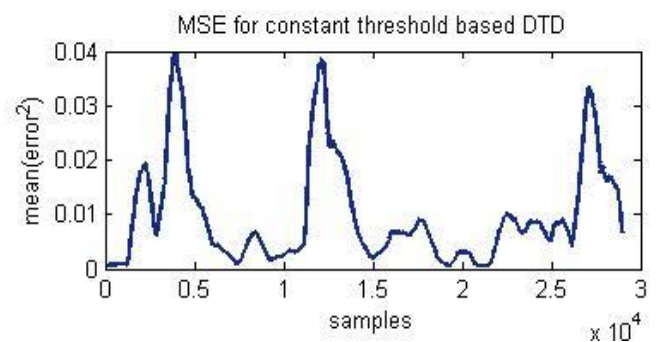

Fig-6.Simulation result of Mean Square Error

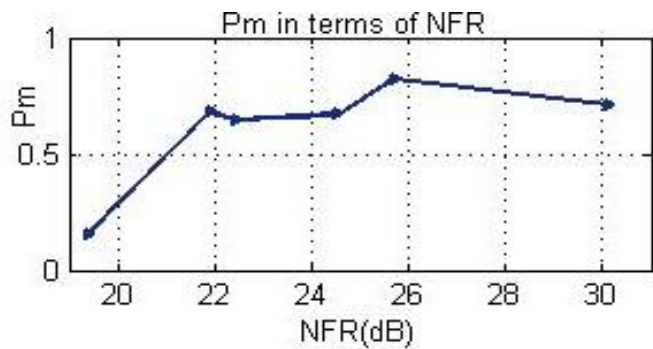

Fig-7.Simulation result of Probability of missed detection w.r.t NFR

4.2 Results for logic gate based DTD

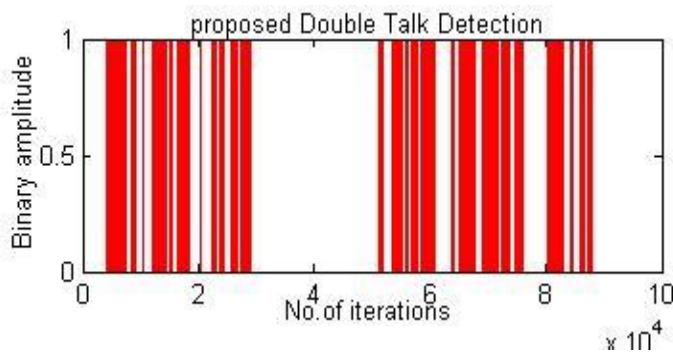

Fig-8.Simulation result of Double Talk Detection

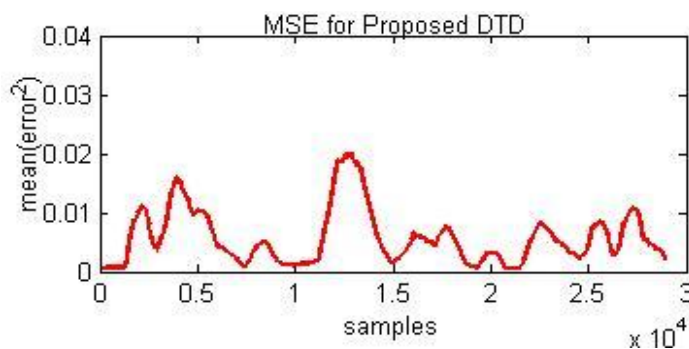

Fig-9.Simulation result of Mean Square Error

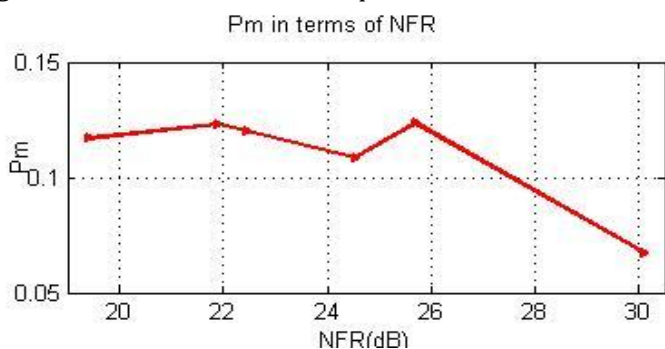

Fig-10.Simulation result of Probability of missed detection w.r.t NFR

Table -3: Comparison between constant threshold based DTD and proposed method

parameter	Constant Threshold based DTD	Proposed Method
Max ERLE(dB)	45	65
MSE	0.01	0.005
Pd	0.88	1
Pf	0.24	0.08
Pm	0.11	0

5. CONCLUSION

In this paper, a new method is proposed for double talk detection using logic AND gate and this method is compared with cross correlation based DTD with a constant threshold. The experimental results indicates the good performance of proposed method in terms of minimizing mean square error, increasing ERLE, minimizing probability of missed detections and more probability of successful detections.

The future work may focus on determining the performance evaluation for dynamic threshold based DTD for acoustic echo cancellation.

REFERENCES

- [1] Akihiko sugiyama, Jerome berclaz, miki sato, "Noise-Robust Double-Talk Detection Based On Normalized Cross Correlation And A Noise Offset", International Conference on Acoustics, Speech, and Signal Processing - ICASSP, pp. iii/153-iii/156 Vol., 2005
- [2] Per Åhgren, "Acoustic Echo Cancellation and Doubletalk Detection Using Estimated Loudspeaker Impulse Responses", IEEE transactions on speech and audio processing, vol. 13, no. 6 November, 2005.
- [3] Akihiko Sugiyama, J'Erone Berclaz†, Miki Sato]. Benesty, T. Gänsler, "The Fast Cross-Correlation Double-Talk Detector". Signal Processing, vol. 86, No. 6, pp. 1124-1139, Elsevier, 2006
- [4] Wonchul Heo, Taehwan Kim, And Keunsung Bae, "Robust Double-Talk Detection In The Acoustic EchoCanceller Using Normalized Error Signal Power", International conference on acoustics, speech and signal processing,IEEE,2007

- [5] Sonika and Sanjeev Dhull, "Double Talk Detection in Acoustic Echo Cancellation based on Variance Impulse Response", International Journal of Electronics and Communication Engineering, vol. 4, No. 5 , pp. 537-542, 2011
- [6] Ivan J.Tashev, "Coherence based double talk detector with soft decision", International conference on acoustics, speech and signal processing, IEEE, 2012
- [7] V. K. Gupta, Mahesh Chandra and S. N. Sharan, "Acoustic Echo and Noise Cancellation System for Hand-Free Telecommunication using Variable Step Size Algorithms", Radio engineering, vol. 22, no. 1, pp.200-207, 2013.
- [8] Mahfoud Hmidia, Abderrahmane amrouche, "Double Talk Detector based on speech feature extraction for acoustic echo cancellation", International Conference on software, telecommunication and computer networks, IEEE, 2014.
- [9] Vineeta Das, Asutosh Kar ,Mahesh Chandra , " A new cross correlation based double talk detection algorithm for Nonlinear Acoustic Echo Cancellation ," TENCON 2014- IEEE region 10 Conference,2014.
- [10] Mahfoud Hmidia, Abderrahmane amrouche, "A new structure for acoustic echo cancellation in double talk scenario using auxiliary filter", 14th International workshop on acoustic signal enhancement, IEEE, 2014.
- [11] Ein Gyin Pwint, Su Su Yi Mon, Hla Myo Tun, "Design And Simulation Of An Acoustic Echo Cancellation System For Hand-Free Telecommunication", International Journal Of Scientific & Technology Research Volume 4, Issue 06, June 2015.
- [12] Abhishek Deb, Asutosh Kar, Mahesh Chandra, "A Technical Review on Adaptive Algorithms for Acoustic Echo Cancellation", International Conference on Communication and Signal Processing, IEEE April 3-5, 2014.
- [13] Mahesh Chandra, Asutosh Kar, Pankaj Goel, "Performance Evaluation of Adaptive Algorithms for Monophonic Acoustic Echo Cancellation: A Technical Review", International Journal of Applied Engineering Research, vol. 9, no-17, pp. 3781-3806, 2014.
- [14] Harsh Kumar and Sanjeev Dhull, "Performance Analysis of Different DTD Methods for AEC", International Journal for Scientific Research & Development| Vol. 3, Issue 06, 2015.
- [15] Srinivasaprasath Raghavendran, "Implementation of an acoustic echo canceller using MATLAB", Master's thesis, University of South Florida, 2003.
- [16] Hung Ngoc Nguyen, Majid Dowlatnia, Azhar Sarfraz, "Implementation of the LMS and NLMS algorithms for Acoustic Echo Cancellation in teleconference system", Master's thesis, vaxjo university, 2009.
- [17] J.G. Proakis and D.G. Manolakis, Digital Signal processing Principles, Algorithms and Applications 4th edition prentice-hall,2006.
- [18] Harkirat Kaur, Rupinder Kaur and Pulkit Sharma , " A survey on Double Talk Detection based Acoustic Echo Cancellation" , International Conference On Sciences, Engineering And Technical Innovations,2016