

# Design and Development of Centrifugal Oil Cleaner and Finite Element Analysis using ANSYS

Mr. S. D. Chavan<sup>1</sup>, Prof. A. V. Karande<sup>2</sup>

<sup>1</sup>Master of Engineering Student, Department of Mechanical Engineering, DGOIFOE Swami-Chincholi, Bhigwan, Maharashtra, India

<sup>2</sup>Assistant Professor, Department of Mechanical Engineering, DGOIFOE Swami-Chincholi, Bhigwan, Maharashtra, India

\*\*\*

**Abstract** - The engine oil after prolonged use needs to be filtered. Conventional method known are the full flow system and the by-pass system of filtration that use inline filters. But in case of the full flow system there is a possibility of engine seizure due to lack of oil if oil filter gets congested, so also the rate of flow through fine filters is limited thereby putting a limitation on its use. The by-pass system uses the concept of a diverted flow that ensure that oil always reaches the engine, irrespective whether it is filtered or non-filtered, this may prevent engine seizure but may lead to unduly wear of engine parts. Moreover the passage of oil through the bypass system suffers the limited discharge predicament. The centrifuge oil cleaner though an effective solution where in the high rate of discharge can be maintained proves to be a costly option today as the cartridge used in the centrifugal oil cleaner needs to be replaced after use which increases the maintenance cost tremendously. The stationary casing type oil cleaner the whole cartridge need not to be change for maintenance reason but only the hygroscopic liner mounted on the inner wall of stationary casing requires to be substituted. This saves a lot of cost. This paper discuss the design and FEA analysis of the modified oil cleaner and evaluate the performance of cleaning of the oil cleaner.

**Key Words:** Cartridge, development, FEA, liner, low maintenance, cost saving, etc.

## 1. INTRODUCTION

Vehicles and equipment repeatedly come across contamination that may cause excessive wear, unreliable operation or complete failure. These destructive contaminants consist of particulate debris from swallowed dust, water, lubricating oil, dirt and wear and microbiological development. Lubricating oil is deteriorated resulting in formation of sludge, lacquer and carbon with use. Additionally it is contaminated by different byproducts of combustion of fuel, water, acids, unburnt fuel. In addition to these fine particles of dust and rust formed in engine are other impurities present in the oil. The oil after passage through the strainer and pump passes through the strainer and pump passes through the oil filter whose purpose is to remove any impurities which might damage the engine bearings. Two types of filter systems are;

### 1.1 By Pass System

In by pass system the whole of oil does not pass the oil through filter at the same time. Most of the oil without being filtered goes to the bearings whereas the rest 10% passing through the filter is cleaned and returned to the sump. In this structure, rate of oil flow through the filter is slow so that very fine filtering elements can be used.

### 1.2 Full flow system

In full flow system all the oil which goes to the bearing must pass through the filter first. Thus if any time filter is blocked in full flow system the oil flow would be blocked and bearings would be starved. To avoid this to happen spring loaded relief valve is incorporated in the filter which passes on emergency supply of unfiltered oil to the bearings, thus saving them oil starvation and subsequent damage.

Centrifuge oil cleaner:

In this cleaner the impure or dirty oil from the engine enters the hollow central spindle having holes around its periphery as shown in fig-01.

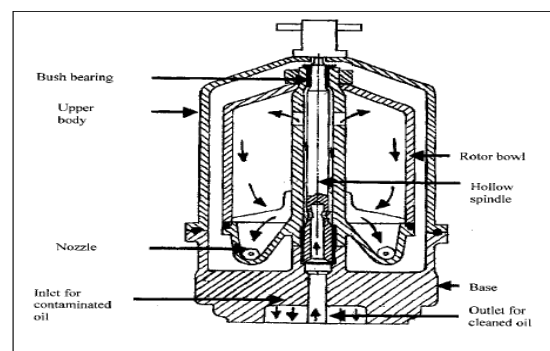

Fig- 1: Schematic Diagram of COC

The dirty oil comes out of these holes and fills the rotor casing after which it passes through these jets, the reaction of which gives the motion to the rotor casing in the reverse direction so that it starts rotating. The oil impinges on the outer stationary casing under impinges on the outer rotating.

The oil impinges on the outer stationary casing under heavy pressures, where the impurities are retained and clean oil falls below from where it is taken out. The filter cartridge has to be replaced every 7000km which enlarge the maintenance cost tremendously. It is Due to routine maintenance necessary for cleaning, too much of man hours used up on this activity.

### A] Problem Statement

Cleanliness of the oil is a vital problem and it have to be free of particulate materials such as sludge, carbon, water, etc. Carbon is formed after departure and fractionation under clauses of insufficient oxygen or is introduced by processes such as carburization. Oil collapse on the allotment surface may happen if sufficient quenching interruption is not provided.

By pass system is obsolete since it has been found statistically impossible to clean whole oil content of system by this method while full flow system the entire oil has to be filtered the rate of flow in this system is quite high due to which, filtering elements used are comparatively coarser.

Lubricating oil is got worse resulting in formation of sludge, lacquer and carbon with use. Further it is contaminated by various by products of combustion of fuel, water, acids, unburnt fuel. In addition to these fine particles of dust and rust formed in engine are other impurities there in the oil. The oil after passage through the strainer and pump passes through the strainer and pump passes through the oil filter whose principle is to remove any impurities which might damage the engine bearings.



**Fig- 2:** Contaminated Rotor

At the moment in oil cleaners, the rotor casing gets wear out due its continues rotating operation also the filter walls have to be clean at interval of about 700km. Lube oil contaminants smaller than 5 microns are the most destructive to the engine, primary to cylinder liner polishing, bearing failure, valve bridge or rocker arm wear and full-flow filter plugging. The moving parts of the cleaner like outer casing, casing liner have higher wear rate such things increases the maintenance cost of the centrifugal oil cleaner at usual interval. Hence, there is need of some design modifications of component parts to reduce maintenance activities.

### B] Objectives

1. The design and operation of the centrifugal oil cleaning systems are based on the basic laws of physics and general chemical engineering principles for specific operating pressure.
2. The design development of the components of the oil cleaner is done in such a way that no. of moving components reduces and also maintenance activities. Modification in the component design and replacement in the mounting method of the components can cause change in operation process and maintenance cost.
3. The layout of components is such that easy servicing is possible especially those components which required frequent servicing can be easily dismantled.

### C] METHODOLOGY

The present work is carried out in seven phases as summarized below

- Phase 1: Data Collection
- Phase 2: System Design
- Phase 3: Mechanical Design
- Phase 4: Production Drawing Preparation
- Phase 5: Material Procurement & Process Planning
- Phase 6: Manufacturing
- Phase 7: Assembly –Test & Trial for 5Mpa working pressure

### 2. LITERTURE REVIEW

**Boll and Kirch et al. [7]** studied the characteristics of the oil change during engine operation. Generated soot particles boost the viscosity of oil which leads to increased fuel consumption, a loss of engine performance and enlarged wear or damage to engine components. The separation of the oil circuit into a main flow with defensive filtration and a bypass flow effects in a stable ideal lubricating oil quality with a small maintenance requirement for oil care and signifies the best achievable defense for the engine. The use of an oil centrifuge for the capable action of lubricating oil is the improved option. This technology is able to remove a full range of particles down to below a micron.

**R.K.Pandey et al. [3]** studied maintenance procedures in industry where the engine manufacturers fit the barrier type full flow and by-pass filters with the engines for effective filtration. Barrier types of by-pass filters are issued to clogging and over sizing problems this accelerates the wear of the system. Due to comparatively complicated geometries of parts Finite Element Analysis of all the parts has been done for their optimization ANSYS (FEA) software has been intended for optimization of parts' geometries. The solid modeling of different components carried out using dimensions, which have been computed. The results of filtration of particulates are encouraging. Conversely, for sub-microns range contaminants filtration extra speed of the

rotor is essential. Therefore research carried on the improvement in rotor speed with permanence.

**Cummins filtration [19]** designed the SpiraTec to efficiently remove and hold sub-5 micron contaminant. Oil entering the SpiraTec rotor exceeds throughout the gaps among spiral vanes which direct the contamination outward to the rotor perimeter where forces are highest. The contamination then gathers forming a compressed sludge cake on the inside rotor wall. The increased separation efficiency is due to the decreased distance the contaminated oil should go inside the rotor before separating and transfer clean oil back to the sump.

**Mann+Hummel[15]** offers both cleanable and throwaway rotor design. Full flow filters are designed to process all the oil utilized to lubricate the moving elements of the engine. Mann+Hummel include patented Swept Rib Technology in the rotor cover. To move the contaminated fluid from the rotor core to the outer edge these ribs are applied where the contaminants are acted upon by superior centrifugal forces, hence aiding cleaning efficiency. Internal rib plastic rotors ensure that the entire oil and thus the contaminant is rotating at the identical speed as the rotor. Internal rib technology also helps to relocate the oil and contaminant from the rotor core to the outer edge due to swept rib design. These two results afford an even superior cleaning effectiveness without compromising contaminant holding facility but this preference is appropriate just for applications where a delivery of compressed air is available.

Efficlean is an Intelligent Oil Filtration System ensuring oil quality, dropping waste and keeping the environment clean [9]. It separates solid from liquid at micron levels, even to the extent of 0.25 microns. It efforts on the principle of centrifugal achievement, where oil will be moved for a fixed number of passes as suggested and dirt free oil sent reversed to the tank. It's a bypass filter, for inlet pressure necessity of 2.5 to 7.0bar a separate pump depending on means to be cleaned. The pressure energy is exchanged to rotational in efficlean which sources particles to build up layer by layer in the rotor walls. Due to gravitational forces dirt free oil from efficlean is sent back to the tank.

### 3. DESIGN CALCULATIONS

#### a) Design of Rotor Turbine:

The set-up of turbine consists of two sets of nozzles, each set containing four nozzles placed at 90° phase difference, each nozzle discharges oil of specific gravity 0.8 at 10 m/sec.

Diameter of nozzle = 3mm = 0.003 m

Area of nozzle = 0.000007068 sqm

Velocity of flow at each nozzle = 10 m/sec

Discharge through each nozzle = area x velocity

$$= 0.000007068 \times 10$$

$$= 0.00007068 \text{ m}^3/\text{s}$$

Torque exerted by oil coming through nozzle =  $r \times \rho \times Q \times V$

$$= 0.040 \times 800 \times 0.00007068 \times 10$$

$$= 0.2226 \text{ Nm}$$

There are eight such nozzles thus the net torque =  $0.2226 \times 8$

$$= 0.18 \text{ Nm}$$

#### b) Speed of Rotation of Turbine:

Torque exerted by oil coming out of nozzle, on turbine

$$= r \times \rho \times Q \times V1$$

$$= 0.04 \times 800 \times 0.00007068 \times (10 - 0.04 \times \omega)$$

Total torque exerted by oil coming out of nozzle, on turbine

$$= 8 \times 0.04 \times 800 \times 0.00007068 \times (10 - 0.04 \times \omega)$$

Since the momentum of flow entering is zero and no external torque is applied on turbine so the resultant torque on the turbine must be zero.

Thus,  $8 \times 0.04 \times 800 \times 0.00007068 \times (10 - 0.04 \times \omega) = 0$

$$\omega = 250 \text{ rad/s}$$

As,

$$\omega = 2\pi N/60$$

$$N = 60 \times 250/2\pi$$

$$N = 2387 \text{ rpm}$$

Thus the turbine will rotate at approximately 2400 rpm

#### c) Design of Turbine Shaft:

The design of hollow shaft consists of calculating the accurate outer and inner diameters from strength and rigidity considerations. Let us assume,  $d_i/d_o=c$ , where the shaft is issued to axial tensile force. The turbine shaft is hollow in construction and the minimum section on the shaft has 20 mm outside diameter whereas 14.5 mm inside diameter.

As Per ASME Code;

**Table 1:** Material Selection

Material	Ultimate Tensile Strength N/mm <sup>2</sup>	Yield Strength N/mm <sup>2</sup>
30C8	400	280

$$f_{s_{max}} = 54 \text{ N/mm}^2$$

Check for torsional shear failure:-

$$T = [(\pi \times f_{s_{act}}) / 16] \times [(D_0^4 - D_i^4) / D_0]$$

$$f_{s_{act}} = 0.1583 \text{ N/mm}^2$$

As  $f_{s_{act}} < f_{s_{all}}$

Shaft is safe under torsional load.

**Table 2:** Material Selection

SR NO.	Description	QTY	MATERIAL
1.	Base Flange	01	AL
2.	Inlet Pipe	01	EN9
3.	Central Pipe	01	EN9
4.	Rotor Base	01	AL
5.	Turbine	01	AL
6.	Rotor Casing	01	MS
7.	Casing	01	MS
8.	Top Bearing Housing	01	EN9
9.	Cap	01	EN9
10.	Nozzle	06	CU
11.	Tank	01	MS
12.	Hose Nozzle (3/8")	01	SS

**4. FINITE ELEMENT ANALYSIS**

ANSYS (FEA) software has been used for optimization of components' geometries. The solid modeling of a variety of

components done with the dimensions, which have been computed, based on strength of materials formulas. The tetrahedron solid-45 solid models elements have been used for meshing. The boundary conditions have been applied for static structural analysis at the appropriate locations. Based on the optimal dimensions the solid models of various components of filter are specified and stress of different components have been analysed. Comparing the mechanical properties of allowable stress of the material chosen for component for 5MPa pressure for gear pump with ANSYS results the outcome have been discussed further.

**i) Inlet Pipe:**

Material for Inlet pipe: Plain Carbon Steel (allowable stress 120N/mm<sup>2</sup>)

The maximum stress stimulated is 1.48 N/mm<sup>2</sup> less than allowable stress, the inlet pipe is safe for given operating pressure.

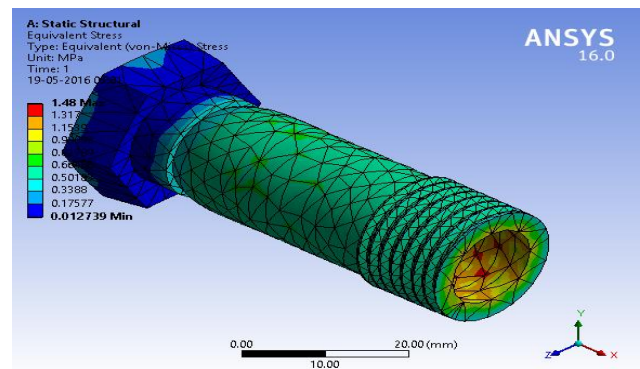

**Fig 03-** Analysis of inlet pipe

**ii) Turbine shaft:**

Material for Inlet pipe: Plain Carbon Steel (allowable stress 120N/mm<sup>2</sup>)

As the maximum stress induced is 1.16N/mm<sup>2</sup> less than allowable stress so turbine shaft is safe for given operating pressure.

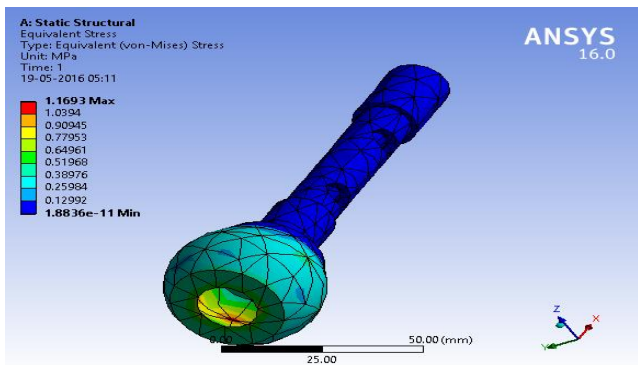

Fig 04- Analysis of turbine shaft

iii) Nozzle:

Material for Inlet pipe: Copper (allowable stress 76N/mm<sup>2</sup>)

As the maximum stress induced is 0.86 N/mm<sup>2</sup> less than allowable stress, the inlet pipe is safe for given operating pressure.

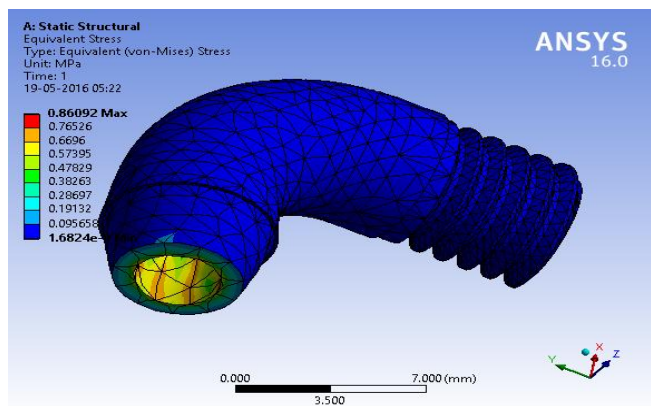

Fig 05- Analysis of nozzle

5. EXPERIMENTAL VALIDATION

Test and evaluation of performance of the Centrifugal oil cleaner with stationary casing:

The stationary casing type oil cleaner does not need the entire cartridge to be replaced for maintenance purpose, but only the hygroscopic liner mounted on the inner wall of stationary casing needs to be replaced. This saves a lot of cost.

The gear pump used for the above operation is selected to keep a operating pressure of 5 to 6 bar with discharge variable from 0 to 3 lit/m.

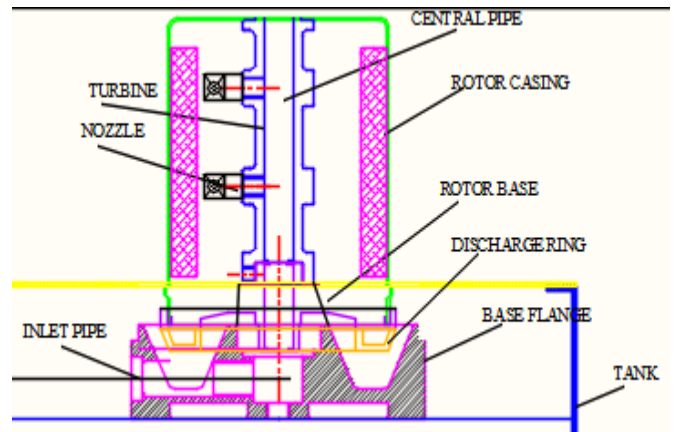

Fig 6- Modified COC layout

Measurement beaker: 0 to 200 ml

Oil (Operating fluid): SAE 20 W 40

Specific gravity = 0.985

Kinematic viscosity in adulterated condition (dirty oil): 11 centistokes @ 40 °C

6. RESULT AND DISCUSSION

Result table for test conducted on Centrifuge oil cleaner

Table 03- Experimental Readings

SR. NO.	Time of test(min)	Mass of dirt/litre ( gm/lit)	Viscosity Centistokes	% Improvement in viscosity
01	10	12	11.6	5.454545
02	15	17	11.9	8.181818
03	20	31	12.15	10.45455
04	25	56	12.37	12.45455
05	30	72	12.58	14.36364

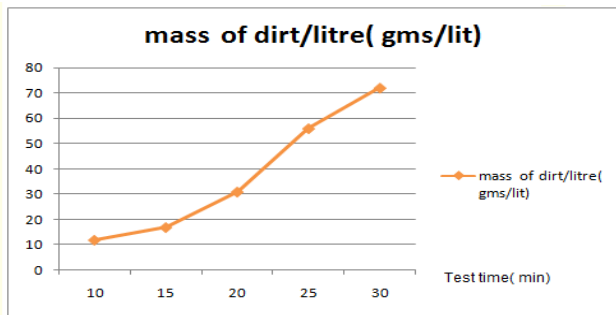

Chart 1- Graph of mass of dirt/lit (gm/lit) Vs Time

Mass of dirt accumulated in the centrifugal filter increases with increase in time.

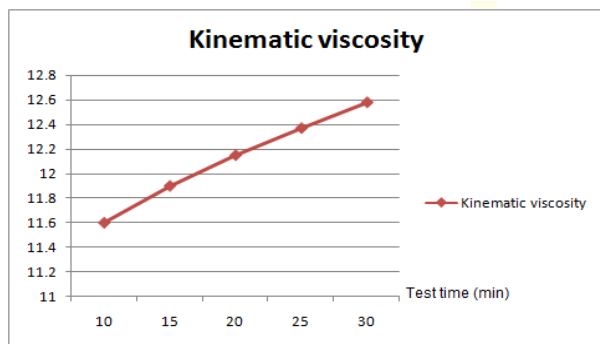

Chart 2- Graph of Kinematic Viscosity of filtered oil Vs Time

## 7. CONCLUSION

1. ANSYS results indicate that the newly designed and modified components (inlet pipe, turbine shaft, nozzle) are safe for operation under given system operating pressure of 5 bar as they shows negligible stress compared to the safe allowable limit of material used for manufacturing hence it is safe.
2. The mass of dirt collected in the centrifugal oil cleaner increases in linear manner over the time span indicating that the centrifugal cleaner effectively removes accumulated dirt for one cycle operation.
3. The kinematic viscosity of the filtered oil increases with increase in testing time indicating that the oil becomes more flowable and usable due to removal of dirt, thereby reducing the possibility of dirt deposits on engine parts.
4. As rotating parts are replaced the modifications in assembly can give more sure reduction in wear of components, the design and development of centrifugal oil cleaner for 5MPa working pressure achieved for dropping maintenance with effective operation.

## ACKNOWLEDGMENT

I would like to express my sincere thanks and gratitude to Prof. Karande A.V. (Mechanical Design Engineering) of DGOI's FOE for their valuable help and guidance. I wish to

express my gratefulness for the most cooperative attitude of Prof. Gaikwad M. U., PG Coordinator for their thoughtful suggestions and the constant moral support. I also thankful to the Principal, DGOI FOE, Swami-Chincholi, Bhigwan for their valuable help at every stage of my research work.

## REFERENCES

1. Energy Conservation through Centrifugal Oil Cleaning System in Industrial Applications, Dr. Anjali Acharya et al Int. Journal of Engineering Research and Applications, ISSN : 2248-9622, Vol. 3, Issue 6, Nov-Dec 2013, pp.1381-1385
2. Nozzle inlet enhancement for a high speed turbine driven centrifuge, Peter K. Herman, United States Patent, 6019717, Feb 2010.
3. Design and Development of Centrifugal Oil Filter for Fine Filtration, R.K. Pandey and V. P. Agrawal 4th International Conference on Industrial Tribology 15-18 December 2004, Mumbai, India
4. EUROPEAN PATENT APPLICATION, Everitt, Christopher James Wilders, 14.06.2000 Bulletin 2000/24, EP 1 008 391 A2
5. Alfa Laval automatic filters, Automatic filters for fuel and lubricating oil, Technical information for oil filtration
6. Autowin system pvt. Ltd, Journal of centrifugal oil cleaning system.
7. Bollfilter Protection Systems, Automatic filtration and maintenance of engine lubricating oil in diesel locomotives
8. Doubling Oil Drain Intervals - The Reality of Centrifugal Bypass Filtration Paul Coombs, Ian Cox and Andrew Samways The Glacier Metal Company Limited
9. Efficlean, Intelligent Oil Filtration System, Ensuring oil quality, reducing waste and keeping the environment clean.
10. Engine lube oil contaminants using solids collected by oil cleaning centrifuge to assess size and composition, Scott A. Rodibaugh, Spinner 2 ,Product division, T.F.Hudgins, Incorporated
11. Evaluation of High Efficiency Oil Filters in the State Fleet, Linda S. Adams Integrated Waste Management Board, California Environmental Protection Agency
12. Filtration technology capabilities, Southwest research institute, San Antonio, Texas
13. Lubrication Filtration Systems, Lube Oil, Hydraulic Fluid, Transmission Fluid and Fluid Conditioning Monitors, Parker Hannifin Corporation Filtration Group
14. The Lube Oil Centrifugal Filter, A retrofittable cleaning system
15. Mann+Hummel Centrifugal Oil Cleaners, High Performance Bypass Oil Filtration, solution for many applications
16. PSG Design Data Book
17. U.S. Department of Energy, Freedom CAR & Vehicle Technologies Program, James Francfort (PI), Timothy Murphy, Larry Zirker
18. ZHF Centrifugal Discharge Filter, Pall GmbH SeitzSchenk, Planiger Strasse 13755543 Bad Kreuznach/Germany
19. Fleetguard, Centriguard with Spiritech, Advanced centrifuge system for maximum soot removal [www.cumminsfiltration.com](http://www.cumminsfiltration.com)