

## INNOVATIVE REFRIGERATOR

**DR.H.K.AMARNATH<sup>1</sup>,SUDHIR PUJARI<sup>2</sup>,VEERENDRA UDOSHI<sup>3</sup>, SIDDHIKUMAR  
PATIL<sup>4</sup>&RAKESHKUMAR KORI<sup>5</sup>**

Department of Mechanical Engineering . Gogte Institute of Technology ,Belagavi

Karantaka ,India

**ABSTRACT** :Manufacturers of refrigeration, governmental agencies, and environmental groups continue working together toward the goal of reduced environmental impact via reduced emissions and improved energy efficiency. Examples of progress are presented for several sectors of refrigeration followed by projections for further significant reductions. Working fluid selection for the refrigeration applications is based on three factors: safety (toxicity and flammability), environmental impact (stratospheric ozone and climate change), and performance (cooling and heating with required capacity, energy efficiency, reliability, and cost effectiveness). Although this paper will emphasize environmental impact for fluid selection, all of the factors must be evaluated to determine the most appropriate fluid for each application.

Refrigeration systems consume a substantial amount of energy. Taking for instance supermarket refrigeration systems as an example they can account for up to 50-80% of the total energy consumption in the supermarket. This paper describes the utilizing escaped heat from cold compartment, which is used to preheat some material in heat compartment, where nearly we can get up to 45-55°C. The heat chamber is preheated up to limited degree of temperature, if we need to heat extra amount, external heater can be connected.

### KEYWORDS:

- power consumption
- refrigeration
- specific heat
- energy consumption
- power consumption
- Heating
- Refrigerants(R134a)
- Valves
- R-134a
- compressor

## INTRODUCTION

Refrigeration is the removal of heat from a material or space, so that its temperature is lower than that of its surroundings. Or removing heat from a substance and rejecting it elsewhere for the primary purpose of lowering the temperature of the enclosed space.

Cold is the absence of heat, hence in order to decrease a temperature, one “removes heat” rather than “adding cold” in order to satisfy the second law of thermodynamics. Some form of work must be performed to accomplish this.

When refrigerant absorbs the unwanted heat, this raises the refrigerant’s temperature (“Saturation Temperature”) so that it changes from a liquid to a gas — it evaporates. The system then uses condensation to release the heat and change the refrigerant back into a liquid. This is called “Latent Heat”.

This cycle is based on the physical principle, that a liquid extracts heat from the surrounding area as it expands (boils) into a gas.

Refrigeration is generally produced by one of the following three ways.

- 1) By melting of a solid.
- 2) By sublimation of a solid.
- 3) By evaporation of a liquid.

Most of the commercial refrigeration is produced by the evaporation of a liquid called refrigerant.

### GENERAL TECHNICAL EXPLANATION OF INNOVATIVE REFRIGERTOR

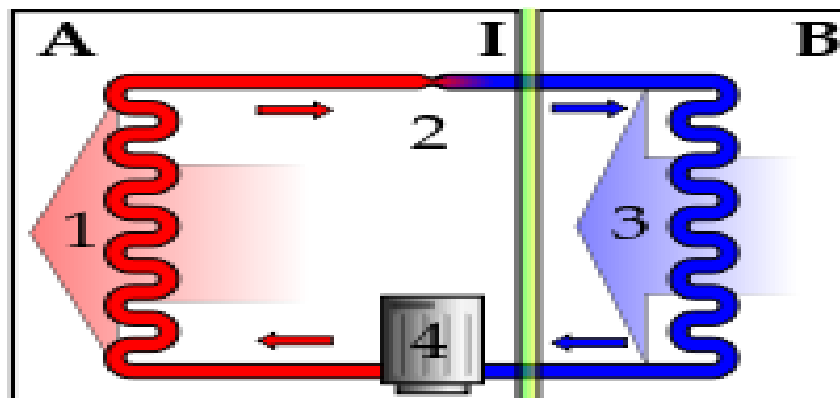

Fig 1. General technical representation

Vapor Compression Cycle – A: hot compartment (kitchen), B: cold compartment (refrigerator box), I: insulation, 1: Condenser, 2: Expansion valve, 3: Evaporator unit, 4: Compressor

A vapor compression cycle is used in most household refrigerators, refrigerator-freezers and freezers. In this cycle, a circulating refrigerant such as R134a enters a compressor as low-pressure vapor at or slightly above the temperature of the refrigerator interior. The vapor is compressed and exits the compressor as high-pressure superheated vapor. The superheated vapor travels under pressure through coils or tubes comprising "the condenser", which are passively cooled by exposure to air in the room. The condenser cools the vapor, which liquefies. As the refrigerant leaves the condenser, it is still under pressure but is now only slightly above room temperature. This liquid refrigerant is forced through a metering or throttling device, also known as an expansion valve (essentially a pin-hole sized constriction in the tubing) to an area of much lower pressure.

### TEMPERATURE ZONES

- -5 °C (41 °F) (refrigerator)
- 50-55 °C (50 °F) (hot compartment)
- The capacity of a refrigerator is measured in either liter or cubic feet.

### CONSTRUCTION OF INNOVATIVE REFRIGERATOR

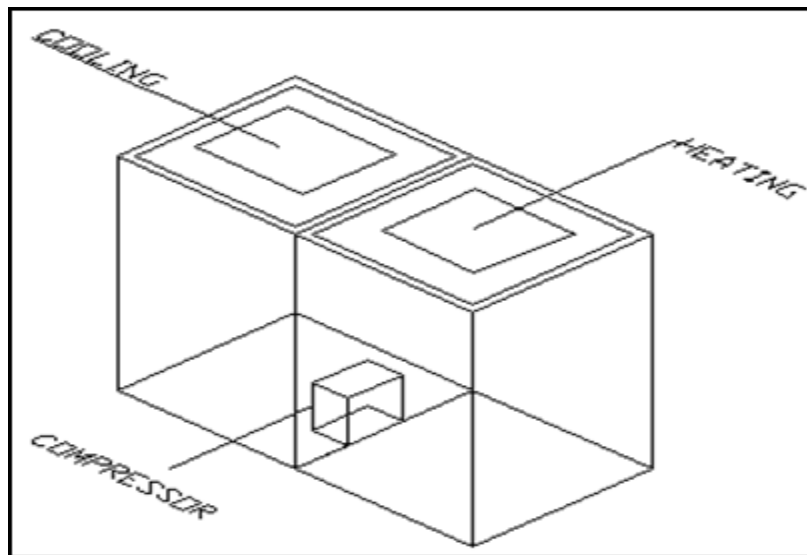

Fig 2. Schematic dig. of Innovative Refrigerator

### **INNER BODY (HOT AND COLD BOX)**

Inner body is made up of G.I. sheet. First of all we take measurement as per requirement of design & mark it on the metal sheet, then it is cut by sizer. Then bending process is done on the cut piece of sheet. In this process sheet get desired shape which is suitable to design. Machine helps to get the required angle of bending like 90, 45, 60 degree. Inner body mainly consists of two components or sections, one is cold section and another one is hot this boxes are made up of metal sheets which is cut as per design then it bend in bending machine. After when require shape and size of box comes out then box join by using soldering material which is made by mixture of lead and tin. After the assembly of box copper tube is fixed to outer surface of both box by using soldering material. Cold box covers 4.48m of copper tube for cooling and hot box covers 4.48m of copper tube for heating. Finally two boxes (hot and cool) are joined together keeping distance of two feet between each box.

Heating compartment, 28x28x28cm, cooling compartment, 28x28x28cm.

### **OUTER BODY**

Outer body is also made up of G.I. sheet. It has six piece of metal sheet front, back, Right hand side, left hand side, top, bottom, & the two more pieces we have to cut which is most important part of refrigerator. Those two pieces are door. Two door for two different compartment. One is cool compartment & another one is hot compartment. This all parts are assembling as per design. The metal angle of 33x35x5 is used as bore of this box. Metal sheet are joined to each other by using soldering material which is mixing of Lead & Tin. Somewhere in body screw are used to fix the two different parts of metal sheet.

### **WORKING**

- The main function of refrigeration says is that to produce cold as well as hot effect. The main parts of our refrigeration are compressor, condenser, and evaporator and expansion devices.
- There three terminals to compressor suction, gas and discharges. The R134a gas filled in the compressor by pressure gauge and exact gas fill control by pressure gauge. The discharge capillary carries the gas through it and passes around the hot where heat can utilised by hot box. In this approximately 55 degree Celsius temp can obtained in this system.
- The gas passes forward where filter can be fixed, in filter dust and moisture can remove after this gas passes towards expansion device where pressure drops and passed through small capillary. At the exit pressure increase and passed through capillary and flow around the cold box, Where cooling effect is

achieved the temperature is around -5 degree Celsius. Which is scuff for our project after this the capillary moves forward towards suction of compression.

## 2D VIEWS PROJECT OVERVIEW

ISOMETRIC VIEW

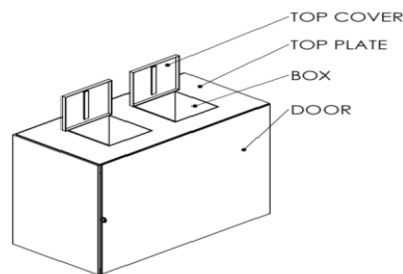

DID NOT SCALE DRAWING	REVISION
TITLE: REFRIDGERATION	
DWG NO. ASSEMBLY. 1 SLDDRW A4	

## ASSEMBLY

FRONT VIEW

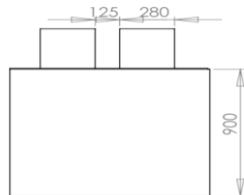

SIDE VIEW

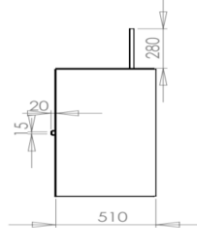

TOP VIEW

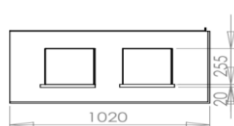

ISOMETRIC VIEW

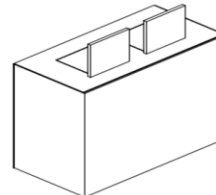

DID NOT SCALE DRAWING	REVISION
TITLE: REFRIDGERATION	
DWG NO. ASSEMBLY A4	

## 2D VIEWS MIDDLE PLATE

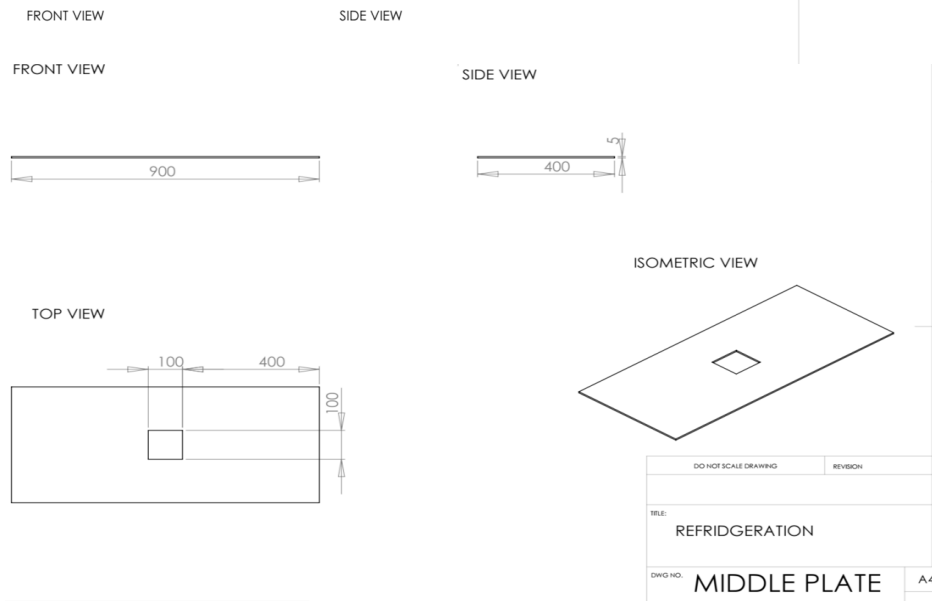

## DOOR

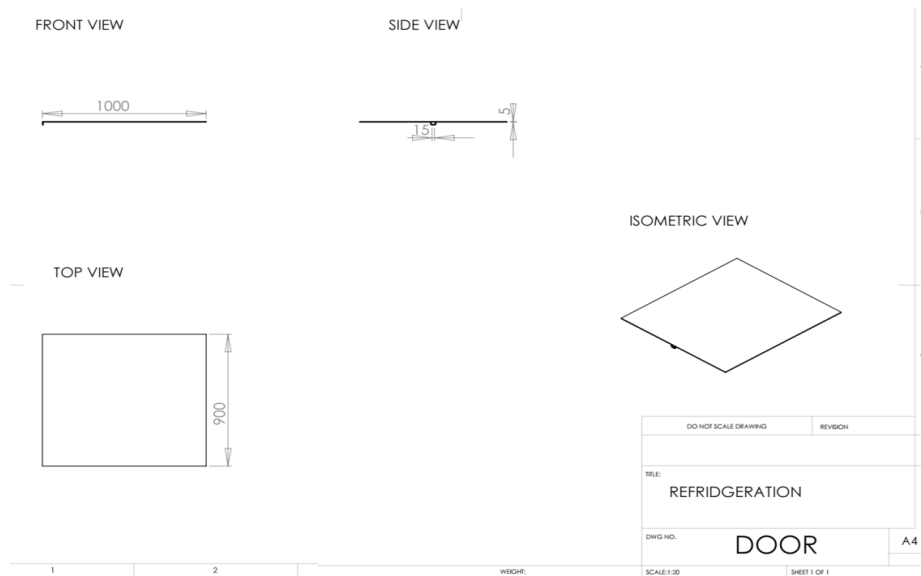

## SPECIFICATION OF COMPRESSOR

### Compressor Pipe Dimensions:

Pipe	OD (mm)	ID (mm)	T(mm)	Material	Remarks
Suction (A)	7.94	6.54	0.7	copper	Suction Pipe bend as per the customer requirement
		6.10	0.9	copper	
Discharge (B)	6.7	5.00	0.85	copper	
Process (C)	7.94	6.54	0.7	copper	
		6.10	0.9	copper	
Oil Cooling (D)	6.35	4.95	0.7	copper	

Refrigerant used in this project is R-134A and R-134A refrigerant given the below advantage and properties

#### R-134a:

1,1,1,2-tetra-fluoroethane CH<sub>2</sub>FCF<sub>3</sub> R134a is a single hydrofluorocarbon or HFC compound.

No chlorine content, no ozone depletion potential.

Modest global warming potential.

ODP = 0 and GWP = 1300

Boiling point = -26.6 °C (-15.9 °F).

Density and phase 0.00425 g/cm<sup>3</sup>, gas. THE

Solubility in water Insoluble.

Melting point -103.3°C (169.85 K) .

\*1,1,1,2-Tetrafluoroethane is an inert gas used primarily as a "high-temperature" refrigerant for domestic refrigeration and automobile air conditioners. Other uses include plastic foam blowing, as a cleaning solvent and as a propellant for the delivery of pharmaceuticals (e.g. bronchodilators), canned air, and in air driers, i.e., for removing the moisture from compressed air.

## UNIT OF REFRIGERATION

The units of refrigeration are always a unit of power. Domestic and commercial refrigerators may be rated in kJ/s, or Btu/h of cooling. For commercial and industrial refrigeration systems most of the world uses the kilowatt (kW) as the basic unit refrigeration.

## THERMAL INSULATION MATERIALS, TECHNICAL CHARACTERISTICS AND SELECTION CRITERIA

### Heat transmission modes and technical terms

It is important to know how heat is transferred in refrigeration systems. Heat is transferred by conduction, convection or radiation, or by a combination of all three. Heat always moves from warmer to colder areas; it seeks a balance.

**Conduction.** By this mode, heat energy is passed through a solid, liquid or gas from molecule to molecule in a material. In order for the heat to be conducted, there should be physical contact between particles and some temperature difference.

**Convection.** By this mode, heat is transferred when a heated air/gas or liquid moves from one place to another, carrying its heat with it. The rate of heat flow will depend on the temperature of the moving gas or liquid and on its rate of flow.

**Radiation.** Heat energy is transmitted in the form of light, as infrared radiation or another form of electromagnetic waves. This energy emanates from a hot body and can travel freely only through completely transparent media.

**Why insulation is necessary :-** The primary function of thermal insulation materials used in refrigeration system vessels is to reduce the transmission of heat through hold walls, hatches, pipes or stanchions into the place where chilled fish or ice or any material is being stored. By reducing the amount of heat leak, the amount of ice that melts can be reduced and so the efficiency of the refrigeration process can be increased. As has already been discussed, ice is used up because it removes heat energy from the fish but also from heat energy leaking through the walls of the storage container.



## **APPLICATIONS OF INNOVATIVE REFRIGERATOR**

- It is commonly appliance used in domestic housing ,
- hotels ,
- laboratories,
- Chemists etc.
- Fast food centres.

## **IMPORTANT REFRIGERATION APPLICATION**

1. Ice making
2. Transportation of foods above and below freezing
3. Industrial air conditioning
4. Comfort air conditioning
5. Chemical and related industries
6. Medical and surgical aids
7. Processing food products and beverages
8. Oil refining and synthetic rubber manufacturing
9. Freezing food products
10. Manufacturing and treatment of metals

**OBSERVATIONS:**

TIME (min)	COLD CHAMBER (degree Celsius)	HOT CHAMBER (degree Celsius)
10	15	38
20	12	42
25	10	45
30	6.5	46
35	5	50

Where **AMBIENT TEMPERATURE** = 29°C ( both regions )

## CALCULATIONS

Heat rejected by air = Heat absorbed by refrigerant

$$h^a A \Delta T = m C_p \Delta T$$

Where,  $m = .08 \text{ kg/sec}$

$$C_p = 905 \text{ J/kg-k}$$

$$\Delta T = (29 - 5) = 24^\circ \text{C}$$

$$m C_p \Delta T = 1738.56 \text{ W}$$

Heat rejected by refrigerant = Heat absorbed by air

$$m C_p \Delta T = h^a A \Delta T$$

Where,  $m = .08 \text{ kg/sec}$

$$C_p = 1218 \text{ J/kg-k}$$

$$\Delta T = (50 - 29) = 21^\circ \text{C}$$

$$M C_p \Delta T = 2046.24 \text{ W}$$

Neglecting all resistances,

Heat absorbed = heat rejected + work done

$$2046.24 = 1738.56 + W \cos \theta$$

$$307.68 \text{ W} = W \cos \theta$$

By theoretical value,

$$\text{Work done} = W \cos \theta$$

$$= 220 \times 1.5 \times .9$$

$$= 330 \text{ W}$$

Which nearly equal to experimental value

### COEFFICIENT OF PERFORMANCE (COP)

COP = heat rejected / work done

$$= 1.738 / .33$$

$$= 5.26$$

### ADVANTAGES

- Heating as well as cooling effect obtained.
- More efficient as compared any other refrigerator.
- Electricity consumption.
- Helpful to reducing global warming.
- It is economical.

### CONCLUSION

Innovative refrigerator is an ecofriendly refrigerator. The heat loss takes place during the condensation process is gained and heating effect is produced. And for heating effect there is no need of any external device. It is basically depends on law of conservation of energy I.e. "energy can neither be created nor be destroyed but it can be transmitted from one form to another form" by this project both heating and cooling effect is produced hence it is used for multipurpose. In this we are using escaped heat towards heat another components which acts like micro oven, which also acts as heater.

### BIBLIOGRAPHY

#### TEXT BOOKS

1. *Thermal engineering by R.K.Rajput.*
2. *Basic thermodynamics by P.K.Nag.*
3. *Applied thermodynamics by Hegde and Murthy.*

4. *Basic and applied thermodynamics by Muralidharan.*

5. *Encyclopedia and Wikipedia.com*

#### **WEBSITES**

6. [www.refrigerator.com](http://www.refrigerator.com)

7. <http://www.journals.elsevier.com/international-journal-of-refrigeration>