

# DESIGN AND FABRICATION OF BAR POLISHING MACHINE

Shrikant B. Pawar<sup>1</sup>, Swapnil K. Koli<sup>2</sup>

<sup>1</sup> BE Scholar, Mechanical, DACOE, Karad, Maharashtra, India

<sup>2</sup> BE Scholar, Mechanical, DACOE, Karad, Maharashtra, India

\*\*\*

**Abstract** - Polishing is one of the oldest processing method used to generate smooth and shiny surface. This smoothness is obtained by rubbing the surface with the polishing particles with a rotating disk. Polishing particles removes small elements of the surface and make them smooth. In a bar polishing machine polishing wheel spins at high speed in a plane perpendicular to the surface to be machined. The depth of cut is governed by the sliding motion of cutter carrier. In this machine three motors are used, one is used for spin the tool and other two are used for sliding tool post in two directions. The tool is travel in three directions (X, Y, Z direction). The 0.25HP and 1550 rpm motor is used for the rotating the tool. The tool used for polishing is Flap disc with 80 and 120 grade. Flat shaped square or rectangular solid as well as drilled work piece are polished by this machine.

**Key Words:** Bar polishing machine, Design, Fabrication, Flat surfaces, Processing.

## 1. INTRODUCTION

Now a days it is necessary to increase production rate continuously in order to achieve higher production rates with minimal of human input, there is need to develop innovative machinery to cater the above needs. Polishing operation is mainly done on the face of the components which is similar to polishing with the view to improve the surface finish of the components. The polishing operation is presently done by mounting an abrasive disk on the spindle of a hand grinder and feeding this rotating disk against the job surface.

Polishing is the process of creating a smooth and shiny surface by rubbing it or using a chemical action, leaving a surface with a significant specular reflection. Polishing is a multistage process. The first stage starts with a rough polishing and each subsequent stage uses a finer emery paper of different grades until the desired finish is achieved. In this stage metal removal takes place. Then in second stage we come across the Fine polishing in which minimal or negligible metal removal takes place. It is mainly used to remove scratches from the surface of specimen. Finally, Etching is the operation of revealing micro-structural features (grain boundaries, phases, precipitates and other micro-structure constituents) of the polished specimen through selective chemical attack on the surface. A common misconception is that a polished surface has a mirror bright

finish, however most mirror bright finishes are actually buffed.

Polishing is often used to enhance the looks of an item, prevent contamination of instruments, remove oxidation, create a reflective surface, or prevent corrosion. In metallography and metallurgy, polishing is used to create a flat, defect-free surface for examination of a metal's microstructure under a microscope. Silicon-based polishing pads or a diamond solution can be used in the polishing process. Polishing stainless steel can also increase the sanitary benefits of stainless steel.

In the Bar Polishing Machine polishing wheel spins at high speed in a plane perpendicular to the surface to be machined, which ensures the flatness of the surface machined and also the parallelism of the opposite surfaces of job being machined. The depth of cut is governed by the sliding motion of cutter carrier in the downward direction where as the wobbling action achieved by the combined rotary and eccentric motion of the work table ensures that even machining takes place all over the surface. To ensure that the complete surface is machined the table slide is provided.

## 2. LITERATURE REVIEW

2.1 Bhaskar Chandra Kandpal, Rajesh Kumar Verma, Dalip Malhotra, Ashish Kumar, Anuj Kumar & Mallika Taneja, (March 2012) published a paper on the **Fabrication of wet grinding machine and measure the metal removal rate using different grades emery paper** says that how the mechanical preparation required during polishing in the paper. It is found that a systematic preparation method is the easiest way to achieve the true structure. The construction of polishing machine is also mentioned in the paper. The material removal rate (MRR) of different grades is given in it. In this paper they also describe grinding and polishing method. The paper gives an idea about fabrication of wet grinding machine (surface). They conclude that with the help of motor and belt drive system reduced the mechanical efforts of users.

2.2 Prof. Gohil, (2014) published paper on the **Design Of Leadscrew Mechanism For Vertical Door Wrapping Machine** says about leadscrew selection in design of leadscrew selection criteria are proposed and gives design for leadscrew. They also give criteria of screw diameter for

various length selection of leadscrew. In this paper they also explained design mechanism of leadscrew.

2.3 Leonard E. Samuels, (2003) published paper on the **Metallographic polishing by mechanical methods**. He is probably best known for his fundamental studies of the mechanisms of grinding and polishing using abrasives and the role of these processes in producing structural changes in surface of metals. In this book they give all the information about polishing with abrasives and their principles. Various effects of abrasives with their grit size changes are mentioned in the book.

2.4 L. Dillinger, (1985) published paper on the **Polishing** says about polished surface properties and related effects on stainless steel after polish. He also examine load elongation curve before surface was polished and after the polish of surface. He took experiment on the 304 stainless steel at different load conditions.

2.5 Hosned, (2014) published paper on **A Construction of Polishing Machine Cooperating with Robot** was illustrate the construction of polishing machine. He makes the polishing machine co-operating with robot. This machine was created for human health perspective because of polluted air contact during polishing operation. The pollution of air caused by emulsions released in the air during polishing operation, when polishing wheel rubbing the polishing surface. He was used robotic arms in their machine.

2.6 David Long, (2014) says in the paper on **How to select right flap disc** that direction to select the right flap disc. He was illustrating features of good flap disc and gives the guideline for selection of flap disc. He was also mentioned all related terms of flap disc like abrasive grit, grit size, flap disc material. In their paper he was also mentioned the how to select flap disc on the basis of grit size and grit size effect on polishing.

2.7 Camedda & C. Turin, (March 2009) published a article in the **Megadyne** was gives guidelines for selection of V- belts in their company manual 'Megadyne'. The manual shows all information about V belts, which type material we use as their application. They also demonstrate the types of V belts with their different applications.

2.8 Ragothsingh, (2009) published article on **How Polishing, Buffing & Burnishing Work** in platers says about was conduct the experiment on stainless steel for measuring roughness of stainless steel after polishing. They do that experiment on polishing machine and for testing its effectiveness. They use different flap disc and buffing wheels for polishing purpose with different grades.

2.9 Avs. Ganeshraja and T. Dheenathayalan, (June 2014) published a paper on **Analysis & Control of Vibration in Grinding machines** says about different vibrations caused

in the grinding machine. He was also mentioned in paper how to control these vibrations. He was took various experiment on machine by different measuring methods. The vibrations are hard to measure; it was witnessed from the formation of waviness on work piece and grinding wheel. Avs. Ganeshraja and their team members measured the vibrations by Velocity measurement mode because velocity defined as the rate of displacement per unit time. He was also says that in their paper how to control the vibrations. Their study tells that vibration was analyzed by the digital vibrometer and controlled by damping method. They also say that by implementing their mentioned methodologies, we can prevent the loss of accuracy and loss of production. He was also classifying the machine on the basis of motors.

2.10 Nemeth Stefan, Neslusam Mirosla, (2007) published a paper on the **Vibration in Grinding Operations** says that the vibrations of grinding operations are carried out by a dynamometer. The measured values were analysed through the FFT analysis. The algorithm which is used in FFT analyse is the Fast Fourier Transform. This produces the optimum frequency resolution from the machines. It is the suitable technique for identifying the cutting ability of grinding wheels.

### 3. DESIGN DATA

#### 3.1 Diagrams

The figures given below shows the details of bar polishing machine

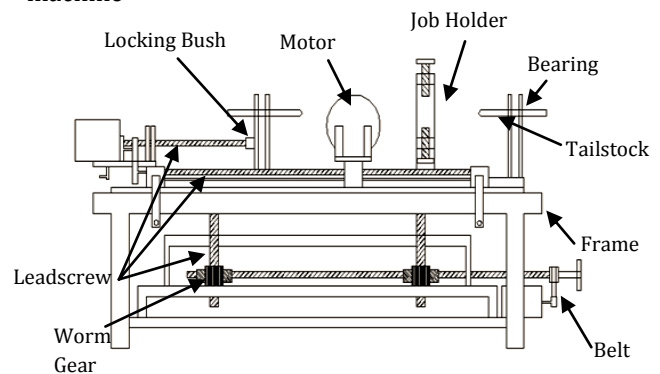

Fig. 3.1.1: 2D front view of Bar polishing machine

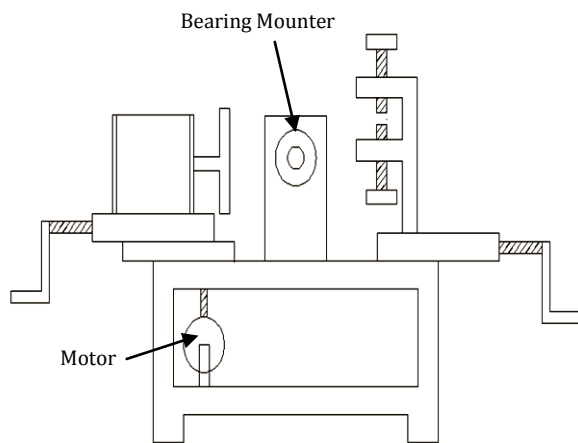

Fig. 3.1.2: L. H. S. View of Bar polishing machine

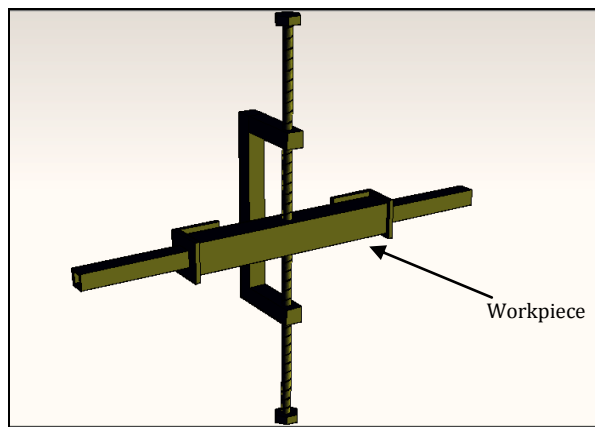

Fig.3.1.3: Workpiece holding arrangement

### 3.2 Working Procedure

- 1) 'ON' main switch.
- 2) Mount the work piece between tailstock horizontally and vertically mount in job holder.
- 3) Set the tool parallel to polishing surface of the work-piece.
- 4) 'ON' the machine.
- 5) After that start the rotating motion of the tool adjust the tool by giving small amount of feed. Give the feed which is used for only touch the tool work-piece and set the tool.
- 6) Move the work-piece horizontally which is operating ON forward backward switch and for that motion another motor is used of 0.02 HP, 60 rpm.
- 7) The second motion of machine is a vertical movement of tool. This motion is start by another motor of 0.02 HP, 60 rpm, which drive the lead screw. The motion from motor shaft to lead screw is transferred by using V belt. That motion transmitted motion rotate lead screw.

- 8) Lead screw rotate in horizontally forward direction or backward direction.
- 9) There are two worm gear are used for convert motion in horizontal to vertically motion. They are meshed with lead screw.
- 10) When lead screws pushing forward switch the worm gears rotates in clockwise direction and tool goes in vertical direction. And if the lead screw moves backward by pulling switch backward direction then worm gear rotates anticlockwise direction and tool goes in downward direction.
- 11) Repeat that process up to which is required surface finish is not obtained.
- 12) Above process for one side of workpiece for another side change the work piece surface by removing it from tailstock.
- 13) Repeat the process for another all sides.
- 14) Obtain require surface finish.
- 15) Stop the machine and then 'OFF' main switch.

### 3.3 Advantages

1. Flatness guaranteed, Surface machined is necessarily flat.
2. No Tool marks on the surface machined.
3. Even polishing on surface.
4. Less Time consuming, suitable for mass production.
5. Dimensional accuracies maintained.
6. Surface finish guaranteed.
7. Parallelism of surfaces machined is maintained.

### 3.4 Photos



3.4.1: Front view of Bar polishing machine



3.4.2: Top view of Bar polishing machine

#### 4. CONCLUSION

There are a lot of inaccuracies present on the surface of workpiece. So, from this project we reduced that all inaccuracies, burs by using bar polishing machine. We get shiny and smooth surface. It also removes scratches from the surface of specimen. Negligible metal removed by using this bar polishing machine. Dimensional inaccuracies, tool marks, uneven polishing are on the surface of workpiece are reduced from this project. We get up to range of 10-15 $\mu$  surface finish using this bar polishing machine. After using that machine there is no requirement of further machining and component can be directly used in assembly. Parallelism of two opposite faces is also obtained by this machine. So from this project we get required smooth surface finish and remove irregularities from the surface.

#### 5. REFERENCES

- [1] Avs. Ganeshraja and T. Dheenathayalan, "Analysis & Control of Vibration in Grinding machines", IJRET, Vol. 03, Issue: 11, June 2014.
- [2] Bhaskar Chandra Kandpal; Rajesh Kumar Verma; Dalip Malhotra; Ashish Kumar; Anuj Kumar; Mallika Taneja, "Fabrication of wet grinding machine and measure the metal removal rate using different grades emery paper", Volume 2, Issue 3, March 2012, ISSN 2250-2459.
- [3] Camedda and C. Turin, "Megadyne", Megadyne S. P. A., March 2009.
- [4] David Long, "How to select right flap disc", Product Finishing, Norton Abrasives, 2014.
- [5] Hosned, "A Construction Of Polishing Machine Cooperating With Robot", Doc. Ing.Vladimir Anddrlik, Csc., 2014.
- [6] I. D. Marinesce, H. K. Tonshoff & I. Inasaki, "Handbook of Ceramic Grinding & Polishing", Noyes Publications/William Andrew Polishing, LLC., 2000.
- [7] Kailaikathir Achagam, "Design Data Book", PSG College of Technology, Coimbatore, 2007.
- [8] Leonard E. Samuels, "Metallographic polishing by mechanical methods", ASM international, 2003.

- [9] L. Dillinger, "Polishing", Met-Tips 13, Leco Corp., 1985.
- [10] Nemeth Stefan and Neslun Mirosola, "Vibration in Grinding Operations"; IJRET, ISSN- 1224-3264, 2007.
- [11] Prof. Gohil, "Design Of Leadscrew Mechanism For Vertical Door Wrapping Machine", IJSRD Vol.2, 2014.
- [12] Prof. V. B. Bhandari, "Design Of Machine Elements", Tata Mc. Grew Hill Publishing Co., New Delhi, 2010.
- [13] Prof. Khurmi & J. K. Gupta, "A Textbook of Machine Design", S Chand, New Delhi, 2005.
- [14] Ragothsingh, "How Polishing, Buffing and Burnishing Work", [http://platers.org/polishing\\_buffing.php](http://platers.org/polishing_buffing.php), 2009.
- [15] S. K. Hajra Choudhury, "Elements of Workshop Technology", Vol. 1, Media Promoters & Publications pvt. Ltd. Mumbai, 1985.

#### BIOGRAPHIES



Mr. Shrikant Bharamu Pawar.  
Pursuing B.E. Mechanical at Dr. Daulatrao Aher College Of Engineering, Karad, from Shivaji University, Kolhapur. (2016)



Mr. Swapnil Kumar Koli.  
Pursuing B.E. Mechanical at Dr. Daulatrao Aher College Of Engineering, Karad, from Shivaji University, Kolhapur. (2016)