

AUTONOMOUS LINE FOLLOWING (IMAGE PROCESSING) ROBOT WITHOUT PRIME MOVER

MUJIB PATHAN¹, DHANANJAY KULKARNI²

¹ME Student, Government College of Engineering Aurangabad, Maharashtra, India

²BE(TY), Government College of Engineering Aurangabad, Maharashtra, India

pathanmujib585@gmail.com, kulkarni1jay@gmail.com

Abstract - This project deals with the "Clean Energy Recharging the World" with the use of conventional energy sources. The development and construction of a line follower robot capable to sense multiple colour combinations and transfer of energy between two robots without physical touch. Eco robot will not be having any actuator to drive itself. The energy to it is given by hybrid robot, in the form of magnetic force and high pressurized air blow. During travelling eco robot will be sensing a white line strip on multiple colour background, such as pink, light blue, orange, green, blue, yellow, etc. It is achieved using raspberry- pi unit (camera and minicomputer) interfacing with servo motor for steering

Key Words: IR (infrared sensor), PS-2, 3(play station), PWM (pulse width modulation).

1. INTRODUCTION

Hybrid robot is equipped with propulsion system to drive the eco robot, these are magnetic and pneumatic unit. Each is applicable for its specific purpose. Robot is having holonomic drive with the help of double row omni wheel chassis. For semi automatic working many sensors are used such as Proximity sensor (IR), Ultrasonic sensor etc. In order to operate the robot, Arduino mega controller along with the USB host shield is used to support the PS-3 controller which controls the robot. Lithium polymer batteries are used to drive motors and arduino.

A match is contested by Red and Blue teams. It lasts 3 minutes at most. Each team consists of two robots: one Eco Robot and one Hybrid Robot. Eco Robot doesn't have an actuator to drive itself. The driving force of Eco Robot is obtained indirectly from Hybrid Robot: for example, wind force, magnetic force, etc., or from the game field structure, gravity force, etc.

Eco Robot carrying Wind Turbine Propeller departs from "Eco Robot Start Zone". It runs along 3 zones; "3 Slopes and Hills" "River" "Down Hill", and aims for "Wind Turbine Station" by receiving driving energy from Hybrid Robot. After Eco Robot reaches at "Wind Turbine Station", Hybrid

Robot gets Wind Turbine Propeller from Eco Robot. Then Hybrid Robot Climbs Wind Turbine Pole and assembles Wind Turbine Propeller on Wind Turbine Engine attached on top of Wind Turbine Pole. The team that successfully assembles Wind Turbine Propeller earlier is the winner of the game. This type of winning is called "Chai-Yo".

2. HARDWARE DESCRIPTIONS

As proposed in a theme two robot must be used, so we used two types of robot i.e. eco and hybrid robot. as described follows

Hybrid Robot:

1 Controller: The Mega 2560 is a microcontroller board based on the ATmega2560. It has 54 digital input/output pins (of which 15 can be used as PWM outputs), 16 analog inputs, 4 UARTs (hardware serial ports), a 16 MHz crystal oscillator, a USB connection, a power jack, an ICSP header, and a reset button. It contains everything needed to support the microcontroller; simply connect it to a computer with a USB cable or power it with a AC-to-DC adapter or battery to get started. The Mega 2560 board is compatible with most shields

2 Distance Measurement Sensor:

Ultrasonic Sensor:

Ultrasonic sensors can be used to solve even the most complex tasks involving the object detection or the level measurement with millimetre precision, because their measuring method works reliably under almost all conditions. No other measuring method can be successfully put to use on such a wide scale and in so many different applications. The devices are extremely robust, making them suitable for even the toughest conditions. The sensor surface cleans itself through vibration. Ultrasonic sensors transmit ultrasonic waves from its sensor head and again receive the ultrasonic waves reflected from an object. By measuring the length of time from the transmission to reception of the sonic wave, it detects the position of the object.

3. Motor Drivers:

Hercules 6V-36V, 15Amp Motor Driver can take up to 30A peak current load and can be operated up to 10 KHz PWM. Motor driver can be interfaced with 3.3V and 5V logic levels. Motor driver has built-in protection from under / over voltage, over temperature and short. Motor Driver has optional ACS714 current sensor for current sensing. You can choose current sensor installation option at the time of placing the order. The Motor driver has terminal block as power connector and 10 pin 2510 type relimate connector for the logic connection. It is suitable for high performance robots, Robocon, Robo-cup, US First, Battle robots etc.

4. Motors:

In order to move the robot, PMDC motors are used with planetary gearbox.

5. USB Host-Shield:

The USB protocol defines two types of devices. One is called the host (or server) and the other one is called peripheral (client). The Host device controls the peripheral device and also provides power to it. When you connect any USB device like a mouse or a keyboard to your computer, your computer acts as the host and controls (or polls) the client device (keyboard or mouse or even an Arduino). The USB Host shield has a separate chip (usually Max3421E), which provides USB Host support. Once you have this shield, your Arduino board can act as USB Host and you can connect other USB devices like keyboard, mouse or even an Android phone and communicate with the device from Arduino itself.

6. PS2 Controller:

The controller is the primary user interface for the PlayStation 2. With its winged shape, analogue controls and abundance of well-positioned buttons, it is easy to use yet powerful. The standard PS2 controller has 15 buttons; all of them, except for Analogue, Start and Select are analogue one analogue joystick on the top left

7. Power Supply:

A lithium-ion battery pack loses only about 5 percent of its charge per month, compared to a 20 percent loss per month for NiMH batteries.

Eco Robot:

1. Raspberry Pi2

The Raspberry Pi 2 Model B is the second generation Raspberry Pi. It replaced the original Raspberry Pi 1 Model B+ in February 2015. It can run the full range of ARM GNU/Linux distributions, including Snappy Ubuntu Core, as

well as Microsoft Windows 10 (see the blog for more information).

2 Raspberry Pi Cameras

The Raspberry Pi camera module is capable of taking full HD 1080p photo and video and can be controlled programmatically.

3. Infrared Proximity Sensor

Infrared sensors use a beam of light to detect the presence or absence of an object. This technology is used to identify size and contrast of an object.

4. Servo Motor

Servo motors do not rotate freely like a standard DC motor. Instead the angle of rotation is limited to 180 Degrees (or so) back and forth. Servo motors receive a control signal that represents an output position and applies power to the DC motor until the shaft turns to the correct position, determined by the position sensor. Fast, high torque, accurate rotation within a limited angle. Generally a high performance alternative to stepper motors, but more complicated setup with PWM tuning. Suited for robotic arms/legs or rudder control etc.

Mechanical components

1. Mechanism of slider (up and down motion of the arm):

To have the up and down sliding motion of the arm that is carrying propulsion unit, following option can be used.

2. Linear rolling bearings: Linear rolling bearings are available as monorail guidance systems, track roller guidancesy stems, shaft guidance systems with linear ball bearings and guidance systems with linear recirculating roller or ball bearing units and as driven units (actuators and tables). These very compact elements with very high load capacity, low friction and high rigidity are available as cage or recirculating systems. Due to their compact design, they can often replace solutions requiring significantly greater space

3. HARDWARE SPECIFICATIONS

Specifications of motor driver

Operating voltage: 6V to 36V

Continuous output current: 15Amp (17Amp if fan is installed)

Infrared Proximity Sensor

Operating Supply: 12-24V dc

Servo motors

Required Pulse: 3-5 Volt Peak to Peak Square Wave
 Operating Voltage: 4.8-7.2 Volts
 Microcontroller: ATmega2560
 Operating Voltage: 5V

4. PROPOSED MECHANISM

Principle: This mechanism converts rotational motion into linear (reciprocating) motion. When motor is rotated causes endless belt to roll over pulleys which is attached to the horizontal aluminum arm. Thus linear bearing slides over the rods .Further aluminum arm reciprocates which can be used for further application.

Chassis: It is the skeleton of the robot. The first part of a robot is its chassis. The shape and size of the chassis depends upon the shape of the robot or vehicle to be made. The shape can be circular, rectangular, and triangular. Circular and rectangular shapes are most widely used but you can make chassis of any desired shape, it can even be irregular depending upon the application of the robot. In order to suite our requirement, i.e. to handle as much as 40 kg load, we have designed octagonal chassis. The Omni-directional wheels, allows robot to have three degrees of freedom in the playing field’s plane .The degrees of freedom are forward translation, lateral translation, and rotation. Three degrees of freedom is the maximum number that is possible in a plane.

Propulsion system:

Magnetic propulsion

Any object that exhibits magnetic properties is called a magnet. Every magnet has two points, or poles, where most of its strength is concentrated; these are designated as a north-seeking pole, or North Pole, and a south-seeking pole, or South Pole, because a suspended magnet tends to orient itself along a north-south line. Since a magnet has two poles, it is sometimes called a magnetic dipole, being analogous to an electric dipole, composed of two opposite charges. The like poles of different magnets repel each other, and the unlike poles attract each other.

Neodymium magnet-

Neodymium magnet is rare earth magnet which is strongest permanent magnet. Rare earth magnets are extremely brittle and also vulnerable to corrosion, so they are usually plated or coated to protect them from breaking, chipping, or crumbling into powder.

Pneumatic system

Eco robot can be propelled with impact of pressurized air jet on the proper curved surface.

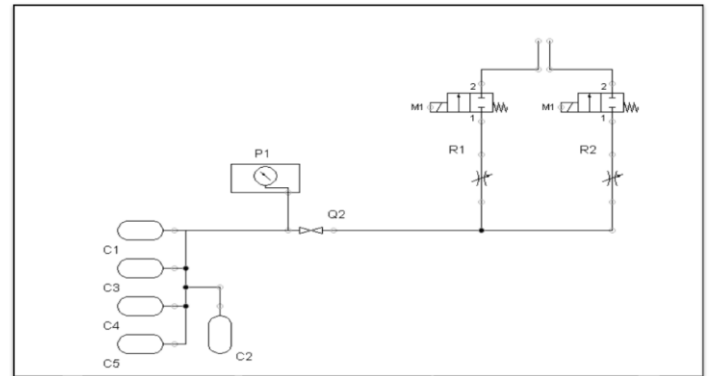

Fig. 1: Pneumatic circuit for propulsion system

Parts required for this mechanism:

1. 2x2 Solenoid Valve
It is used to switch the air supply, according to the electric operated signal.
2. Pneumatic Pipe
This is duct used for the compressed air.
3. Receiver: it is storage of air which is required for various pneumatic tasks..
4. Flow Control Valve: A flow control valve regulates the flow or pressure of a fluid
5. Pressure Gauge
Pressure gauge allows us to control the pressure of outlet air, so that required change in the output can be achieved. A 2x2 Solenoid Valve is used to switch on or off the air flow by operating through PS-3 controller. A relay is used to allow the air flow take place for specified time period
6. Triple Swivel Joints
These are used when a large number of air bottles to be collectively used for any pneumatic application.
7. U- joints
8. On-off valve (hand operated)

5. CONCLUSIONS

By using the slider mechanism accurate motion with the help of ultrasonic sensor is achieved. Many sensors used in a robot simultaneously collaborating each other the same situation can be implement in the Industry. Using the raspberry Pi-2 model B and raspberry Pi camera we have captured images frame by frame, detected and tracked white line strip on red, green, blue , yellow, pink and violet surfaces. The coordinates of line are transmitted serially. The Arduino are given as an input to pin library and its output of pin library is used to drive the servo motor attached on echo library. “Clean Energy Recharging the World” we have designed the robot such that to create the awareness of efficient energy consumption and clean renewable energy utilization

ACKNOWLEDGEMENT

The authors are thankful to the following persons Dr. P. S Adwani (Principal), Dr. A .G. Thosar (HOD), Dr. R. K. Srivastava, Dr.Balchandra A.S. Prof. Kolhare Nilima, Dr.Deodhar Kulkarni, Prof.Mrs.Agrawal, Prof.Harne M.S., Prof.Hirekhan S.R, Dr.U.J.Kahalekar, Dr. D.G. Regulwar, Prof Sohel Shaikh, Mr.Shastri, Mr.Husai M.R. for the publication of this paper.

REFERENCES

- 1) J. W. Dong, and G.. B. Brosilow, —Design of robust multivariable PID controllers via IMC,|| Proc. American Control Conference, Albuquerque, New Meico, pp.3380-
- 2) Z. Wang, Modern electricity hydraulic servo control. Beijing: Beijing University of Aeronautics & Astronautics Press, 2005.pp.15,18.
- 3) P. Pillay and R. Krishnan, “Modeling, Simulation and Analysis of Permanent-Magnet Motor Drives, Part 11: TheBrushless DC Motor Drive,” IEEE Trans. Ind. Applications Vol. 25, Mar|Apr 1989, pp.274-279.
- 4) Zhang, Y., Yu, F., and Huang, K, "Permanent-Magnet DC Motor Actuators Application in Automotive Energy-Regenerative Active Suspensions," SAE Technical Paper 2009-01
- 5) Wai Phyo Aung , “Analysis on Modeling and Simulink of DC Motor and its Driving System Used for Wheeled Mobile Robot” World Academy of Science, Engineering and Technology, :8, 2007