

WIRELESS DATA TRANSMISSION THROUGH LIGHT

Bindu K¹, Kavyashree A L², Lakshmi Kiran V³, Mallika⁴, Mahanthesha U⁵

¹ Student, Dept. of Instrumentation Technology, GSSSIETW Mysuru, Karnataka, India

² Student, Dept. of Instrumentation Technology, GSSSIETW Mysuru, Karnataka, India

³ Student, Dept. of Instrumentation Technology, GSSSIETW Mysuru, Karnataka, India

⁴ Students, Dept. of Instrumentation Technology, GSSSIETW Mysuru, Karnataka, India

⁵ Assistant Professor, Dept. of Instrumentation Technology, GSSSIETW, Mysuru, Karnataka, India

Abstract - Li-Fi stands for light-fidelity. This technology is very new and was proposed by the German Physicist Harald Hass. Li-Fi means transmission of data through an LED light bulb that varies in intensity faster than human eye can follow. In this project ,there are two modes of operation .One is data mode ,in which the data is transmitted through LED and second one is robot mode ,in which the robot is moved in any directions with respect to the keys configured .This paper also gives information , how Wi-Fi is replaced by Li-Fi.

Wi-Fi is used for general wireless coverage within buildings whereas Li-Fi is model for high density wireless data coverage in restricted areas in which there are no obstacles. Li-Fi is a wireless optical networking technology that uses light emitting diodes for transmission of data. The term Li-Fi refers to VLC technology that uses as medium to deliver high-speed communication in a manner similar to Wi-Fi. Li-Fi provides better efficiency, bandwidth, availability and security than Wi-Fi and has already achieved high speeds in the lab. This paper provides a detailed explanation of Li-Fi technology, its benefits and future scope.

Key Words: Visible Light Communication (VLC), LED (Light Emitting Diode), Wi-Fi (Wireless -Fidelity), Visible Light Communication (VLC), LED (Light Emitting Diode), Wi-Fi (Wireless -Fidelity),TTL (Transistor transistor logic),RF(Radio frequency), LCD(Liquid Crystal Display).

1. INTRODUCTION

Light Fidelity means transmission of data through illumination, by taking the fiber out of fiber optics and transmitting the data through a LED light bulb that varies in intensity faster than the human eye can follow. In total Li-Fi Technology is called Visible Light Communication (VLC). It is used for fast and cheap wireless-communication system.

“At the heart of this technology is a new generation of high brightness light-emitting diodes”, says Harald Haas from the University of Edinburgh, UK; which means that, if the LED is

on, the data is transmitted and it is considered as digital 1, if LED is off, then the data is not transmitted and it is considered as digital 0.

It is possible to encode the data in the light by varying the rate at which the LEDs turn on and off to give different strings of 1s and 0s.The output appears constant as LEDs intensity modulates rapidly which cannot be noticed by human eye.

2. PROPOSED WORK

BLOCK DIAGRAM:

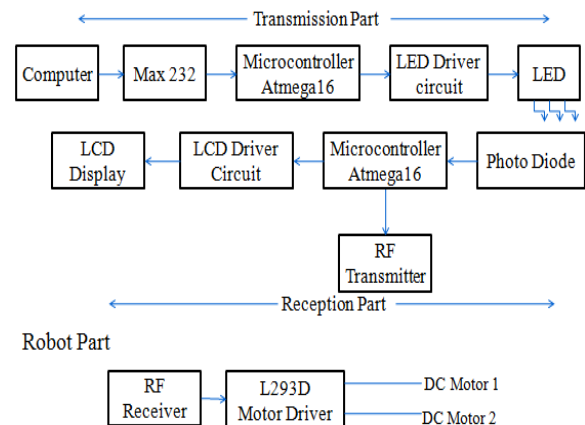

Fig 2.1: Block diagram of wireless data transmission through LED

Transmission Part: The computer gives the data input to the microcontroller(ATMEGA 16) through serial port.MAX-232 is 16 pin IC, which converts the signals from,RS232 serial port to signals suitable for use in TTL compatible digital logic circuit. Microcontroller receives the signal at TTL levels at various ports and converts the data into binary format.LED driver circuit is used for data transmission. Here LED acts as a light source, which transmits the binary output of the microcontroller in the form of light intensity pattern which is then transmitted.

Receiving part: Photo diode which is used to convert light into electrical signals. Those electrical signals are given to the microcontroller. Microcontroller which converts these signals into characters and through LCD driver circuit and it is displayed on the LCD.

Robot part: Microcontroller which controls the robot through RF transmitter and RF receiver. Here we use L293D motor driver IC to drive the motor in either directions. L293D is a 16 pin IC which can control a set of 2 DC motors simultaneously in any direction. It works with the concept of H-bridge.

3. DESIGN METHODOLOGY

3.1 DATA MODE

In the transmission part, LED is continuously on. When a key is pressed, its ASCII value is converted to its corresponding Binary value (byte to bit conversion) and the binary value is transmitted bitwise through the LED.

Transmission logic: To transmit binary 0, LED is off for 1ms and to transmit binary 1, LED is off for 500µs and the bit to bit delay is taken as 10ms. This timing logic is to make the receiver understand whether 0 or 1 is received. Transistor is used as switch to turn on and off the transistor.

In the reception part, we have photodiode which is reverse biased and it works in photoconductive mode. When photodiode is exposed to light, the voltage across the photodiode changes accordingly with the LED on and off switching. This photodiode captures the light signals from the LED and convert it into electrical signal. If the produced voltage is greater than 3.3V, it is considered as logic 1 and if it is less than 0.8V, it is considered as logic 0.

Reception logic: When LED is off, a negative edge interrupt is generated. Intermediate delay of 500µs and 1ms i.e. 750µs is considered. If the LED is off for a time less than 750µs, the data transmitted is considered as 1 and if LED is off for a time greater than 750µs, data transmitted is considered as 0. Once all the 8 bits are received, the binary value is converted to its corresponding ASCII value (bit to byte conversion) and displayed on the LCD.

3.2 ROBO MODE

The robot is moved according to the commands given. The robot is programmed to move left, right, forward and backward using the arrow keys. Here we use RF transmitter and receiver to transmit and receive the data and accordingly move the robot and display on the LCD screen. L293d is used as H-bridge. It allows the voltage to flow in either directions to rotate the motor in clock and anticlockwise directions. The received light data is converted to 4 bit binary data and transmitted through RF transmitter and received through RF receiver on the robot.

3.4 FLOW CHART

The transmission and reception part of is explained using flowchart is as shown in the Fig 3.4(a) & Fig 3.4(b)

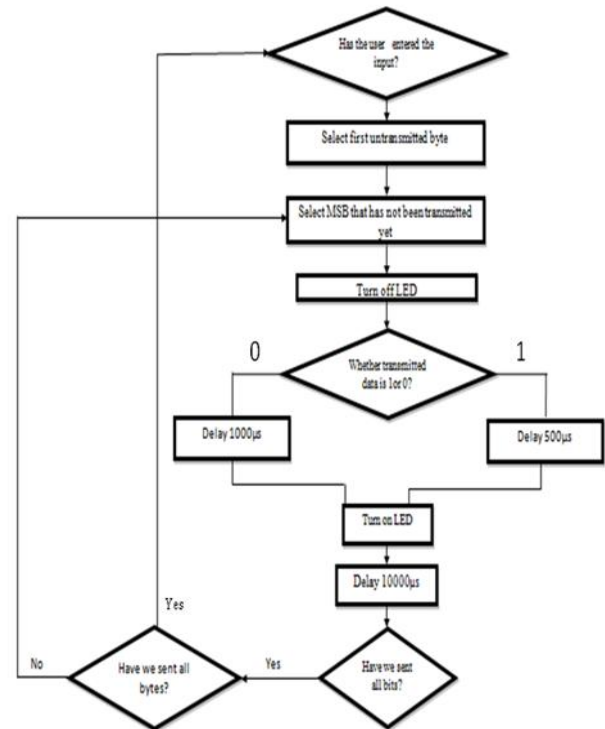

Fig 3.4(a) Transmission part

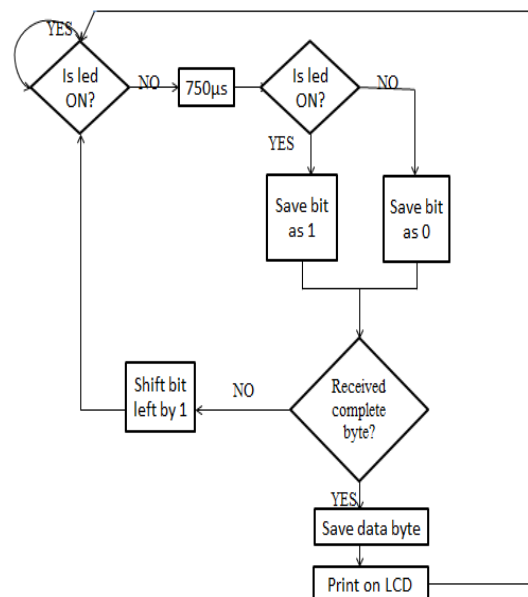

Fig 3.4(b) Reception part

4. CONCLUSIONS

LI-FI is the upcoming and ongoing technology acting as a competent for various other developing and already invented technologies. And also this concept of LI-FI is currently attracting a great deal of interest offering a genuine and efficient alternative to radio based wireless. In this every bulb can be used something like WI-FI hotspot to transmit wireless data. And if this technology comes into practice it creates a revolution in the field of wireless data transmission, making world greener, safer, cleaner and a brighter place to live.

2009. He has published many National & International journal and conference papers. His areas of interest are AEC, C++, Computer Networks, Signals & Systems, DSP, and Control Systems. Presently, he is working as Assistant Professor in the Dept. of Electronics & Instrumentation Engineering at GSSS Institute of Engineering & Technology for Women, Mysuru.

REFERENCES

- [1] "Harald Haas: Wireless data from every light bulb". ted.com.
- [2] Anthony Cuthbertson (23 November 2015). "LiFi internet: First real-world usage boasts speed 100 times faster than WiFi". Retrieved 3 December 2015.
- [3] Tsonev, Dobroslav; Videv, Stefan; Haas, Harald (December 18, 2013). "Light fidelity (Li-Fi): towards all-optical networking". Proc. SPIE (Broadband Access Communication Technologies VIII) 9007 (2). doi:10.1117/12.2044649.
- [4] Sherman, Joshua (30 October 2013). "How LED Light Bulbs could replace Wi-Fi". Digital Trends. Retrieved 29 November 2015.

BIOGRAPHIES

Bindu K, Studying B.E in the dept. of Instrumentation Technology at GSSS Institute of Technology for Women, Mysuru.

Kavyashree A L, Studying B.E in the dept. of Instrumentation Technology at GSSS Institute of Technology for Women, Mysuru.

Lakshmi Kiran V, Studying B.E in the dept. of Instrumentation Technology at GSSS Institute of Technology for Women, Mysuru.

Mallika, Studying B.E in the dept. of Instrumentation Technology at GSSS Institute of Technology for Women, Mysuru.

Mr. Mahanthesha U, Pursuing Ph.D in the field of "Image Processing". He Obtained M-Tech degree in Computer Networking Engineering at National Institute of Engineering, Mysuru under VTU Belgaum in 2014. He obtained his B.E degree in Electronics and Communication Engineering at HMS Institute of Technology, Tumkur under VTU Blegaum in