

A REVIEW OF DESIGN DIGITAL FILTER FOR HARMONICS REDUCTION IN POWER SYSTEM

Prashant Nagare¹, Dr. Sachin Pable², Dr. A.K. Kureshi³

¹Electronics and Telecommunication, Matoshri College of Engineering and Research Center, India

²Electronics and Telecommunication, Matoshri College of Engineering and Research Center, India

³Electronics and Telecommunication, Vishwabharti Academy's College of Engineering, India

Abstract - Harmonics that are created by non-linear devices connected to the power system. Power system harmonics are multiples integer of the fundamental power system frequency and these harmonic frequencies can create distorted voltages and currents. Distortion of voltages and currents can impact on the power system adversely causing power quality problems. Therefore, approximation of harmonics is of high importance for efficiency of the power system network to maintain the quality limits recommended by standards to protect the sensitive loads, it is necessary to enclosed some form of filtering device to the power system. filter is a device which passes specific frequencies while rejecting all other unwanted frequencies that fall outside range. Designing digital filter is one of the methods to control harmonic alleviation problems and improve power quality by delivering electrical power to the system. This paper presents the evaluation of digital filter design and harmonic analysis to the system. In order to achieve an adequate distortion, increase the power quality and to reduce the harmonics hence several digital filters are used. In this paper we have focused on digital filter such as FIR filter, IIR filter and their designing methods

heating, temperature increase in generators, etc. These effects may result into permanent damage of the devices.

The filter plays a crucial role in analog and digital signal processing. Analog filters basically consist of resistor (R), capacitor (C) and inductor (L) which are also called passive components. The digital filter has two types such as IIR and FIR filter. Digital FIR filter constructed a linear phase digital filter which is convenient for data transmission and image processing applications. Whereas IIR filter is used in high speed and low-power communication transceivers system applications. As FIR requires large memory in order to store the previous input and forgoing output but FIR need less memory space to store present and past value of input. IIR contain following properties: the width of the pass-band, stop-band, limited ripple at pass-band and stop-band. The IIR filter types are Butterworth, Chebyshev, Elliptic.

Key Words: Harmonics, non-linear devices, digital filter, power quality, FIR filter, IIR filter.

2.POWER SYSTEM HARMONICS

1.INTRODUCTION

This paper provides overview of harmonics and designing digital filter with different types.

Harmonics nothing but the sinusoidal components of a repetitive waveform which consist of frequencies that are exact multiples or harmonic orders of fundamental frequency. A complete set of harmonics then makes up a Fourier series which together represent the original waveform. Harmonics are currents, usually in multiples of the supply fundamental frequency, generated by non-linear loads such as AC to DC power conversion circuits. For example, a 50Hz supply with 5th harmonic is 250Hz, 7th harmonic is 350Hz and other order harmonics.

Power transmission system are design for operation with sinusoidal voltage and current waveform in constant frequency. However, when non-linear device like thyristors drives, converters and arc furnace are connected to the system, excessive harmonic currents are created and this reason both current and voltage distortion. Also, some non-linear loads and electronics equipment's are such that alternate of drawing current sinusoidally they tend to draw current in short pulses thus producing harmonics. Some of the examples of non-linear devices would be rectifiers, inverters, etc. The examples of electronics equipment's would be PC, scanner, printer, etc. Some of the major issues involved with harmonics in non-linear devices are excessive

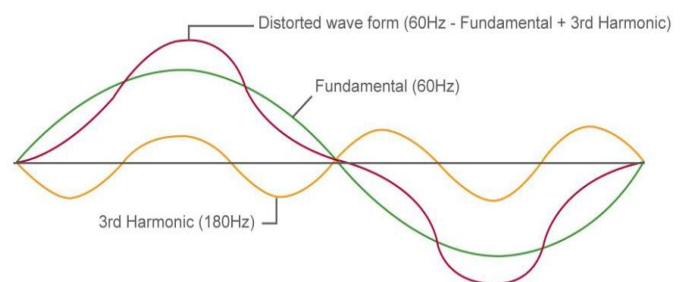

Fig -1: Fundamental wave 60Hz with harmonics distortion

2.1 SOURCES OF HARMONICS

Major sources of voltage and current harmonic generation in power systems are

- **Electric arc furnaces** – The V-I characteristics of electric arcs are non-linear. The arc ignition, voltage decreases due to the short-circuit current, the value which is only limited by the power system impedance. The harmonics produced by electric arc furnaces are not definitely predicted due to variation of the arc feed material and it gives the worst distortion.
- **Magnetic Circuits** – The magnetic devices such as transformers operated in non-linear regions it will produce distorted wave shapes.
- **Power Electronics** – The switching devices such as silicon controlled rectifier (SCRs) and thyristors will produce electrical wave shapes that are not in sinusoidal nature. These devices contain variable speed drivers (VSD) or electronic power supplies

2.2 CONSEQUENCE OF HARMONICS

- **Transformer** – Transformers are serving all linear and non-linear loads. There are two main effects of harmonics for transformers, extra losses and triplen harmonic currents. The losses originate from stray magnetic losses in the eddy current and resistive losses in the windings. These additional losses are creating extra heat significantly reducing the operating life of the transformer insulation.
- **Circuit breakers** - The main harmonic related issue with circuit breakers is nuisance tripping. As nuisance tripping may cause production shut down or interruption with corresponding time required to start the installation up again, it is a very serious and costly effect of harmonics.
- **Electric and electronic equipment** - The electric devices are quite sensitive for harmonic distortion. Usually the result is abnormal function caused by different effects of harmonics. These effects are increase of the maximum value of the supply voltage and digital signal misinterpretation due to harmonic disturbances.
- **Motors and Generators** – The effect of harmonics for motors and generators is additional power losses with the result of a significantly rising temperature of the devices. The reason is the effective resistance increases with increasing frequency. Thus, a current distorted by harmonics will cause greater losses in the windings which subsequently result in greater heating.

- **Cables** - Cable losses, dissolute as heat, are substantially increased when carrying harmonic currents due to elevated I^2R losses, the cable resistance(R), calculated by its DC value plus skin and proximity effect. The resistance of a conductor is based on the frequency of the current being carried.

2.3 ESTIMATION OF HARMONICS

In order to dispense the customers and electrical benefits a quality of power, it is imperative to know the harmonics specifications such as magnitude and phase. This is necessary to designing the filter for eliminating or reducing the effects of harmonics in the power system. Many algorithms have been proposed for the evaluation of harmonics. To obtain the V and I frequency spectrum from discrete time samples, most frequency domain harmonic analysis algorithms are depending on the Discrete Fourier Transform (DFT) or on the Fast Fourier Transform (FFT) method. In this paper we have comprehensive study of the digital filter such as FIR, IIR filter.

3. DIGITAL FILTER IN POWER SYSTEM

There are two fundamental types of digital filters such as finite impulse response (FIR) and infinite impulse response (IIR). As the term suggests, these classifications refer to the filter's impulse response. By increasing the weight of the coefficients and the amount of filter taps, virtually any frequency response characteristic can be realized with an FIR filter. As has been shown, FIR filters can reach performance levels which are not possible with analog filter methods (such as perfect linear phase response). However, high performances FIR filters generally require a large number of multiply accumulates (MAC) and therefore require fast and efficient DSPs and ARM. On the other hand, IIR filters tend to impersonate the performance of traditional analog filters and make use of feedback. Therefore, their impulse response expands over an infinite period of time. Because of feedback, IIR filters can be implemented with fewer coefficients than FIR filter. Finally, digital filters lend themselves to adaptive filtering applications simply because of the filter characteristics can be changed by varying the filter coefficients.

- **Infinite Impulse Response (IIR) Filters** - If the impulse response of a filter is not a finite-length sequence, the filter is called an IIR filter. Equation can be generalized to the transfer function of the IIR filter as

$$\begin{aligned}
 y(n) &= b_0x(n) + b_1x(n-1) + b_2x(n-2) + \dots + b_{L-1}x(n-L+1) \\
 &\quad - a_1y(n-1) - a_2y(n-2) - \dots - a_My(n-M) \\
 &= \sum_{l=0}^{L-1} b_lx(n-l) - \sum_{m=1}^M a_my(n-m),
 \end{aligned}
 \tag{1}$$

Where, the coefficient sets $\{b_i\}$ and $\{a_m\}$ are constants that determine the filter's characteristics. Taking the z-transform of both sides in Equation and arranging terms, we obtain

$$H(z) = \frac{b_0 + b_1z^{-1} + b_2z^{-2} + \dots + b_{L-1}z^{-(L-1)}}{1 + a_1z^{-1} + a_2z^{-2} + \dots + a_Mz^{-M}} = \frac{\sum_{i=0}^{L-1} b_i z^{-i}}{\sum_{m=0}^M a_m z^{-m}} \quad \dots(2)$$

Where $a_0 = 1$. Note that if all of the denominator coefficients $a_m, m = 1, 2, \dots, M$ are equal to zero, $H(z)$ is identical to $B(z)$. The realization structure of IIR filter as shown below

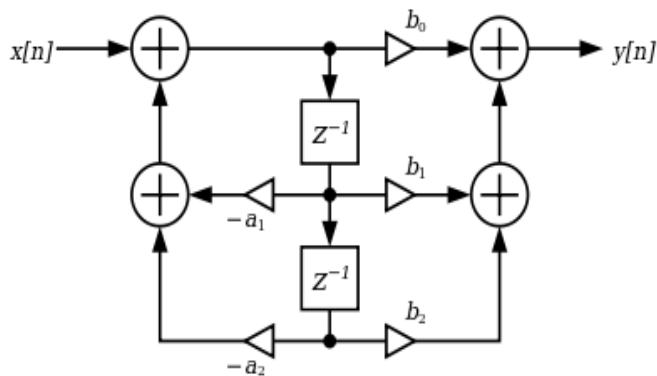

Fig -2: Structure of IIR filter

- **Finite Impulse Response (FIR) Filters** - A FIR filter is a recursive filter that has a transfer function of the form:

$$H(z) = b_0 + b_1z^{-1} + \dots + b_{N-1}z^{1-N} = \sum_{n=0}^{N-1} b_n z^{-n} \quad \dots(3)$$

Hence the impulse response $h[n]$ is

$$h[n] = \begin{cases} b_n, & 0 \leq n \leq N-1 \\ 0, & \text{elsewhere} \end{cases} \quad \dots(4)$$

FIR filter design techniques contain the window function, frequency sampling, minimize the maximal error, and MSE. The structure of FIR filters with length L as shown below. It consists of delay unit, multiplier and adder block.

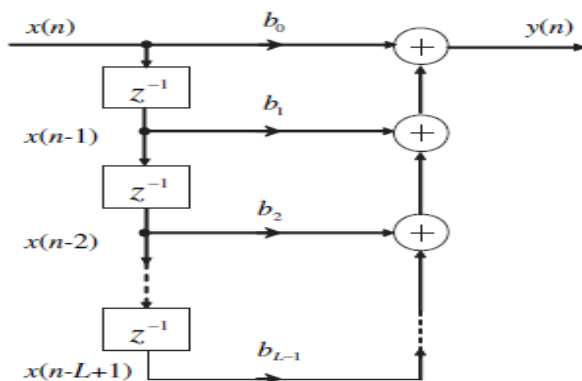

Fig -3: Structure of FIR filter

3.1 Comparison between FIR and IIR filter

Table -1: Comparison between FIR and IIR filter

Sr. No	IIR	FIR
1	IIR filter having non-linear phase response, phase distortion	FIR filter having linear phase response, no phase distortion
2	IIR filter is not always stable $H(n) = a^n u(n)$ $a < 1$... (stable) $a > 1$... (unstable)	FIR filter is always stable
3	IIR filter is recursive	FIR is Non-recursive
4	Quantization noise effect is more	Quantization noise effect is less
5	Used for graphic equalizer for digital audio	Used for speech processing, data transmission and correlation process
6	Less coefficient	Required more coefficient to produce accurate result
7	Less storage required	Large storage required

3.2 FIR filter design flow chart

The designing digital filter involves following five steps.

- **Filter specification:** This may include stating the type of filter, for example low pass filter, the desired amplitude and/or phase responses and the tolerances, the sampling frequency, the word length of the input data.
- **Filter coefficient calculation:** The coefficient of a transfer function $H(z)$ is determined in this step, which will satisfy the given specification. The choice of coefficient calculation method will be influenced by several factors. The most important of which are the critical requirements i.e. specification. The window, optimal and frequency sampling method are the most commonly used.
- **Realization:** This involves converting the transfer function into a suitable filter network or structure.
- **Analysis of finite word length effects:** The effect of quantizing the filter coefficients and input data as well as the effect of carrying out the filtering.
- **Implementation:** This involves producing the software code and/or hardware and performing the actual filtering.

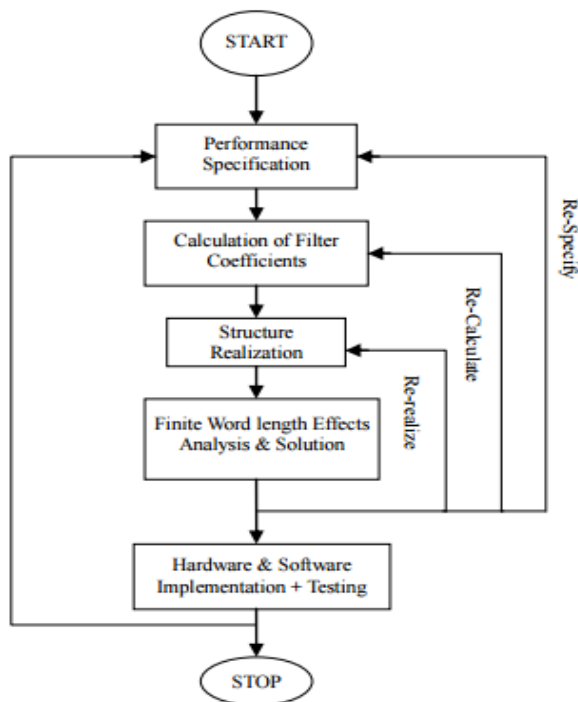

Fig - 4: Flow chart of digital filter design

3.3 Windows method

Windows are used to operate data (original signal) in such a way, that the desired information can be extracted from the spectrum. They are used to trim the infinite impulse response of an ideal filter with the result being an FIR filter. There are many types of window namely Rectangular, Bartlett, Blackman, Hanning, Kaiser and Hamming for use in spectral analysis and filter design. The mathematical equations and comparisons of window method as shown below

- **Hamming window**

$$w_m[n] = \begin{cases} 0.54 - 0.46 \cos\left(\frac{2\pi n}{N-1}\right), & 0 \leq n \leq N-1 \\ 0, & \text{elsewhere} \end{cases} \quad \dots(5)$$

- **Rectangular window**

$$w[n] = \begin{cases} 1, & 0 \leq n \leq M \\ 0, & \text{otherwise} \end{cases} \quad \dots(6)$$

- **Bartlett window**

$$w[n] = \begin{cases} \frac{2n}{M}, & 0 \leq n \leq M/2 \\ 2 - \frac{2n}{M}, & M/2 < n \leq M \\ 0, & \text{otherwise} \end{cases} \quad \dots(7)$$

- **Hanning Window**

$$w[n] = \begin{cases} \frac{1}{2} \left[1 - \cos \frac{2\pi n}{M} \right], & 0 \leq n \leq M \\ 0, & \text{otherwise} \end{cases} \quad \dots(8)$$

- **Blackman Window**

$$w[n] = \begin{cases} 0.42 - 0.5 \cos \frac{2\pi n}{M} + 0.08 \cos \frac{4\pi n}{M}, & 0 \leq n \leq M \\ 0, & \text{otherwise} \end{cases} \quad \dots(9)$$

- **Kaiser Window**

$$w[n] = \frac{I_0[\beta \sqrt{1 - (1 - \frac{2n}{M})^2}]}{I_0[\beta]}, \quad n = 0, 1, \dots, M \quad \dots(10)$$

- **Windows comparison**

Table - 2: Summary of commonly used window function characteristics

Window	Transition width of main lobe	Minimum stop band deviation dB
Rectangular	$\frac{4\pi}{M}$	-21
Hanning	$\frac{8\pi}{M}$	-44
Hamming	$\frac{8\pi}{M}$	-53
Blackman	$\frac{12\pi}{M}$	-74
Bartlett	$\frac{8\pi}{M}$	-25

4. CONCLUSIONS

In the last few years, harmonics is a big problem for the electrical distribution design in the modern technical college as it pollutes the power. From this survey, it is possible to identify that which loads are responsible for high level of distortion and we can find out their distortion level. The review paper provides the background information on system harmonic levels before the new non-linear loads bring into operation and helps in deciding the specification of new equipment's to be established in the industries and college. The results of harmonic measurements also help to define electrical environment and base line for future harmonic surveys to analyze the quality of power. From this information one can know whether the harmonics do a significant hazard to the electrical system and steps should be taken to mitigate the harmonics in order to improve the quality of power.

ACKNOWLEDGEMENT

I would like express our deepest gratitude and profound appreciation to our project supervisor Dr. Sachin Pable, for his patience, motivation, expert guidance and constructive suggestion for fulfillment of our project work. I would like to express our sincere thanks to Prof. D. D. Dighe, Head of the Department, Electronics and Telecommunication Engineering for his invaluable suggestion and constant support throughout the project work.

Last but not the least; I would like to thank our parents, family and all well-wishers for their cooperation, sacrifice and motivational moral support which bring us to this level.

REFERENCES

- [1] Jeena Joy, Amalraj P.M., Ashwin Raghunath, Nidheesh M.N., Vinu Joseph, "Harmonic Analysis of 230 V AC Power Supply Using LPC2138 microcontroller," ISSN: 2347-1964 (Online) 2347-1875 (Print) Vol.2, Issue 8, August 2014.
- [2] Akanksha Mittal, Amit Rege, "Design of Digital FIR Filter Implemented with Window Techniques for Reduction of Power Line Interference from ECG Signal," IEEE International Conference on Computer, Communication and Control (IC4-2015).
- [3] Sonal Dwivedi, "Comparison and Implementation of Different Types of IIR Filters for Lower Order & Economic Rate," IJESTA Volume 01, No. 10, October 2015.
- [4] "Survey paper on digital IIR filter uses GA" paper published in the international journal of innovative research in computer and communication engineering-IJIRCCCE volume 3, issue 6, June 2015.
- [5] Sonal Dwivedi, Pankaj Shrivastav, "Survey Paper on Digital IIR Filter Using Evolutionary Algorithms," IJIRCCCE Vol. 3, Issue 6, June 2015.
- [6] Designing of IIR filter with multi-objective GA" Paper Published in international journal of modern trends in engineering and research (IJMTER), volume 2, issue 4, April 2015.
- [7] Ashishdeep Kaur, Ranjit Kaur, "Survey on FIR Digital Filter Design," An International Journal of Engineering Sciences, January 2016, Vol. 17 ISSN: 2229-6913 (Print), ISSN: 2320-0332 (Online).
- [8] J Er. Sandeep Kaur, Er. Sangeet Pal Kaur, "Design of FIR filter using hanning window, hamming window and modified hamming window," International Journal of Advanced Research in Computer Engineering & Technology (IJARCET) Volume 4 Issue 5, May 2015.
- [9] L. Litwin, FIR and IIR digital filters, IEEE Potentials 0278-6648, pp.28-31, 2000.
- [10] Andreas Antoniou, "Digital filters analysis, Design and applications", Tata McGraw-Hill, 2nd Ed. 1999
- [11] Rashid M.H, "Power Electronics-Circuits, Devices and Applications", third edition Prentice Hall India, 2001.