

EXPERIMENTAL ANALYSIS FOR ENHANCEMENT OF HEAT TRANSFER IN TWO PASS SOLAR AIR HEATER DUCT BY USING SQUARE RIB IN DISCRETE GEOMETRY

Sandeep kumar dehariya¹, Dr. A. R. Jaurker²

1. Student, M.E. (Heat Power engg.), Jabalpur Engineering College, Jabalpur, India

2. Professor Jabalpur Engineering College Jabalpur, India

Abstract - Heat transfer plays an important role in the field of thermal engineering. Heat transfer involves transfer of heat energy without transfer of mass and plays most important role in the field of power plant, refrigeration and air conditioning, electric transformer, and electronic equipment etc., Heat transfer take place by three modes i.e. Conduction, convection and radiation. It is found that the convective heat transfer coefficient between hot gas to metal and hot metal to air is low. Due to the low value of heat transfer coefficient, the performance of the heat transfer system which is working with air as a working fluid is low. Artificial roughness is defined by non-dimensional parameters as relative roughness pitch, relative roughness height and relative modifications for easy of analysis of system, comprising and evaluating of systems. A lot of research work is found in the field of enhancement of heat transfer by application of artificial roughness in the form of ribs as listed in details. This paper presents the experimental investigation of Heat transfer characteristics of a rectangular duct roughened with square ribs in discrete geometry are arranged at an inclination with respect to the flow direction on its underside on one broad wall. Artificial roughness in the form of ribs is a conventional method for enhancing the performance of solar air heater. Range of parameters for this study has been decided on basis of practical considerations of system and operating conditions. Relative roughness pitch (p/e) 6-12, relative roughness height (e/Dh) 0.0287, angle of attack (α) 90° and Reynolds number (Re) 2000-12000. The experimental conducted for four different roughened duct and smooth duct under similar geometrical and flow pattern. The effect of roughness parameters on Nusselt number (Nu) has been determined and the results obtained were compared with those of smooth duct. The maximum enhancement of heat transfer as compared to smooth is found on the relative roughness pitch (p/e) 10 and discrete in geometry in the range of parameters under investigation.

Key Words: artificial roughness, solar air heater, square shaped roughness, relative roughness, relative roughness height.

1.INTRODUCTION

Solar energy is radiant light and heat from the sun that is harnessed using a range of ever evolving technologies such as solar heating, photovoltaic, solar thermal energy etc.it is an important source of renewable energy and its technologies are broadly characterized as either passive solar or active solar depending on how they capture and distribute solar energy or convert into solar powers. Solar energy is also used in solar water heating and solar air heating.

Solar air heaters are simple in design and construction. Efficiency of a flat plate solar air heater is low because of low convective heat transfer coefficient between air and absorber plate. Friction loss is occurring due the roughness in absorber plate so turbulence has to be crated as close to heat transferring surface. This is done by keeping height of roughness element is small. Several investigations have been carried out to study effect of artificial roughness on heat transfer and friction factor for two opposite roughened surfaces by S.K. Verma and B.N. Prasad [24] studied the effect of protruding wires on friction factor, heat transfer coefficient and plate efficiency factor of a solar air heater, Prasad and Saini [28] studied the effect of roughness and flow parameters such as relative roughness height (e/D) and relative roughness pitch (p/e) on heat transfer and friction factor. M.M. Sahu et al.[27] experimentally investigated the heat transfer coefficient by using 900 broken transverse ribs on absorber plate of a solar air heater. Chaube Alok et al [37] Analysis the heat transfer augmentation and flow characteristic due to square Rib roughness over absorber plate of a solar air heater.

2. EXPERIMENTAL SETUP AND PROCEDURE

An experimental setup has been designed and fabricated to study the enhancement of heat transfer having transverse staggered discrete ribs made of square wire on the absorber plate of rectangular duct. The flow system consists of an entry section, test section and an exit section, a flow measuring orifice plate and a centrifugal blower with a control valve. The air enters at entry section and test section where the atmospheric air gets heated by taking heat from the absorber plate which gets its heat from electric heater. The wooden rectangular duct of internal size 2100 mm X 200 mm X 25 mm includes entrance section, test section and exit sections mixing, length of 400 mm, 1500 mm, and 200 mm respectively. The exit section of 200 mm length is

used after test section in order to reduce the end effects in the test section. An electrical heater of size 1500 mm X 200 mm was fabricated by Nichrome wire of 25 SWG on 5 mm asbestos sheet to supply constant heat flux of 1067W/m². A 25mm cotton wool of thermal conductivity 0.029W/m K was applied as insulation. The top side of entry and exit sections of the duct is covered with smooth face of 12 mm thick plywood. The heated plate is 1mm thick G.I plate on which square rib made of square wire has been pasted with the help of flex glue. The mass flow rate of the air is measured by means of an orifice plate connected with a U tube manometer with distilled water as manometer fluid and flow is controlled by the control valves provided in the pipe line.

The air is sucked through the rectangular duct by means of a blower driven by a 3-phase 440V, 2.3kW and 1420 rpm, A.C. motor. Before starting the experimental all the thermocouples were checked carefully so that they give the room temperature and all the pressure tapings were checked for the leakage problem. A digital multimeter is used to indicate the output of the thermocouples through the selector switch.

Fig. 1: Experimental Diagram of Experimental Setup

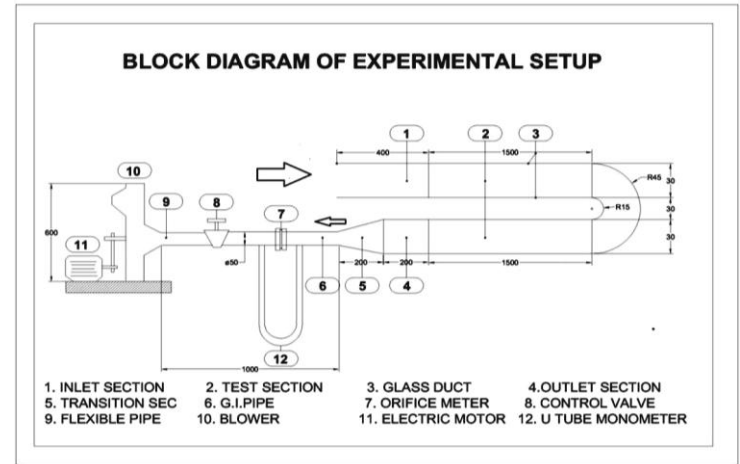

Fig. 2 : Schematic of Experimental Set up and Cross Section of Duct

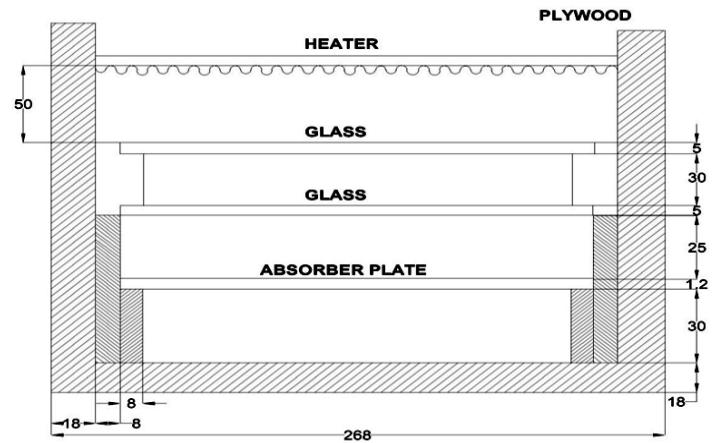

Fig. 3 : Schematic Diagram square ribs in discrete geometry

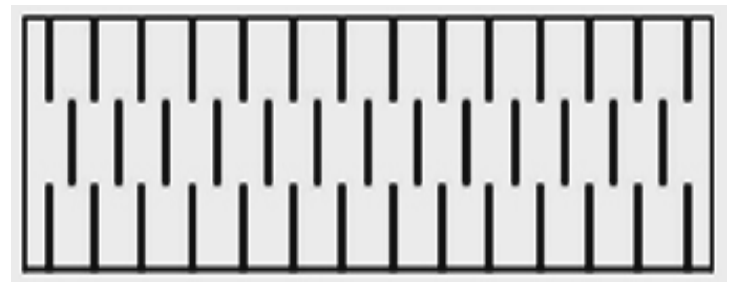

Fig.5: Position of Thermocouple (All dimensions in mm)

Experimental investigation of the setup test runs to collect the relevant heat transfer data were conducted under steady state condition. The power supply to the centrifugal blower and electric heater was switched on and the desired flow rate was set with the help of control valves. In order to ensure the arrival of steady state conditions the values of temperature indicated by all the thermocouples were observed at regular interval 10 min. The steady state attains in about 2 hrs when all the temperature and pressures were recorded. Four sets of roughened absorber plates, having relative roughness pitch (p/e) 6-12. The following parameters were measured and ranges of parameters in table 1.

1. Temperature of the heated plate.
2. Temperature of air at inlet and outlet of test section of the duct.
3. Pressure difference across orifice meter

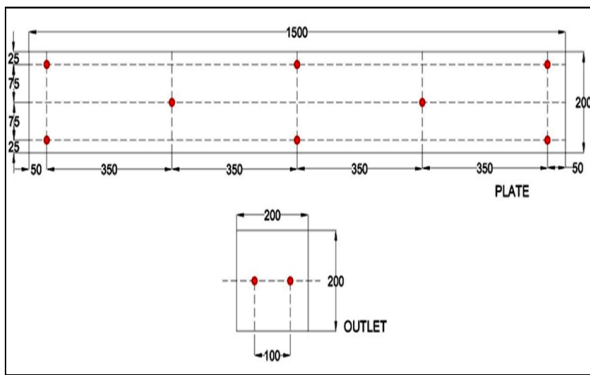

Table 1: Roughness Parameters of Range

The analysis was carried out for the following ranges of parameters.

Reynolds number, Re	2000- 15000
Relative roughness pitch, p/e	6- 12
Relative roughness height, e/D _h	0.0287
Angle of attack, α	90°

3. EXPERIMENTAL DATA REDUCTION

The experimental data includes thermocouple readings and air mass flow rates. This data have been reduced to obtain the average plate temperature, average air temperature, velocity of air flow in the ducts (mass flow rate and flow Reynolds number) and the value of heat transfer coefficient.

The thermo physical properties of the air have been taken at the average plate fluid temperature. Test results have been presented in the form of thermal parameters viz. Nusselt number, Reynolds number and also the thermal efficiency. Roughness's parameters have been given in the form of relative roughness height (e/D_h), relative roughness pitch (p/e) and angle of attack (α).

1) Mean Air And Plate Temperature

The mean air flow temperature or average flow temperature T_f is the simplest arithmetic mean of the measure values at the inlet and exits of test section.

$$T_f = (T_{i1} + T_o)/2$$

2) Pressure Drop Calculation

Pressure drop calculation across the Orifice plate was made by using the following relationship

$$\Delta P_o = \sqrt{\Delta h \times 9.81 \times \rho_m}$$

3) Mass Flow Measurement

Mass flow rate of air has been determined from pressure drop measurement across the orifice by using the following relationship

$$\dot{m} = C_d A_o \sqrt{\frac{2\rho(\Delta P_o)}{1 - \beta^4}}$$

4) Velocity Measurement

$$V = \frac{\dot{m}}{\rho \times W \times H}$$

5) Reynolds Number

$$Re = \frac{VD_h}{\nu}$$

6) Friction factor:

The friction factor is determined from the measured values of pressure drop, $(\Delta p)_d$, across the test section length, L_f , of 1.5 m.

$$f_r = \frac{2(\Delta p)_d D_h}{4\rho L_f V^2}$$

7) Heat Transfer Coefficient

Heat transfer rate, Q_{air} , to the air is given by

$$Q_{air} = \dot{m}c_p (T_o - T_i)$$

8) Nusselt Number

The heat transfer coefficient has been used to determine the Nusselt Number as

$$Nu = \frac{hD_h}{k}$$

9) Thermal Efficiency (η)

$$\eta = \frac{G C_p (T_o - T_i)}{I}$$

4. Validity Test

To validate the results of present work for heat transfer in the form of Nusselt number and friction factor determined from experimental data were compared with the analytical values obtained from well-known correlations given in the literature as Dittus boelter equation and modified Blasius equation respectively. It shows good arrangement between experimental and analytical values i.e. in the limit of $\pm 5\%$. This ensures the accuracy of the experimental data with the present set up.

Dittus boelter equation: $Nu = 0.023Re^{0.8}Pr^{0.4}$

Modified Blasius equation: $f_s = 0.085Re^{-0.25}$

5. RESULTS AND DISCUSSION

Using the data obtained from experiments, the heat transfer, friction factor characteristics of duct are discussed as follows:

5.1 Variation of Nusselt Number with Reynolds Number

Fig. 5.1 shows the variation of Nusselt number with the Reynolds number for the square rib at different relative roughness pitch, having fixed value of relative roughness height (e/D_h) and angle of attack (α). It has been observed that Nusselt number increases with increases of Reynolds number for all value of relative roughness pitch (p/e) as compared to smooth duct. This is due to a distinct change in the fluid flow characteristics as a result of roughness that causes flow separations, reattachments and the generations of secondary flows. It is seen that for a constant values of Reynolds number the value of Nusselt number increases with increasing relative roughness pitch (p/e) from 6 to 10 and then decreases on increasing relative roughness pitch (p/e).

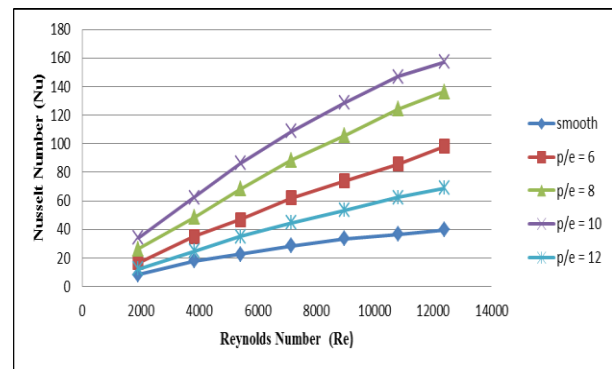

Fig. 5.1

5.2 Variation of Nusselt Number with Relative Roughness Pitch

Fig. 5.2 shows the plot of Nusselt number as a function of relative roughness pitch at different Reynolds number for fixed value of relative roughness height (e/D) and angle of attack (α). It has been observed that for any particular value of Reynolds number, Nusselt number attain maximum corresponding to relative roughness pitch (p/e) value of 10 and on either side of this value, the Nusselt number is decreases.

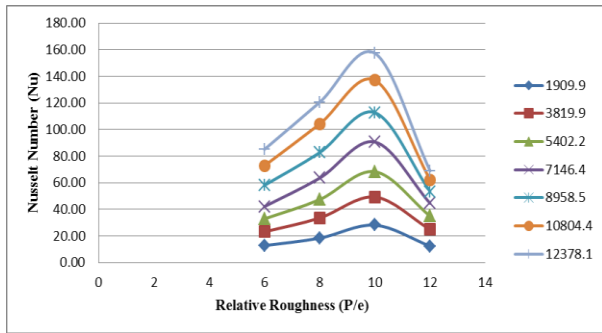

Fig. 5.2

5.3 Variation of Heat Transfer Coefficient with Relative Roughness pitch

Fig 5.3 the effect of relative roughness pitch on heat transfer coefficient is shown at different Reynolds number. It can be seen that the value of heat transfer coefficient increases with increasing the value of relative roughness pitch (p/e). These results are in line with literature.

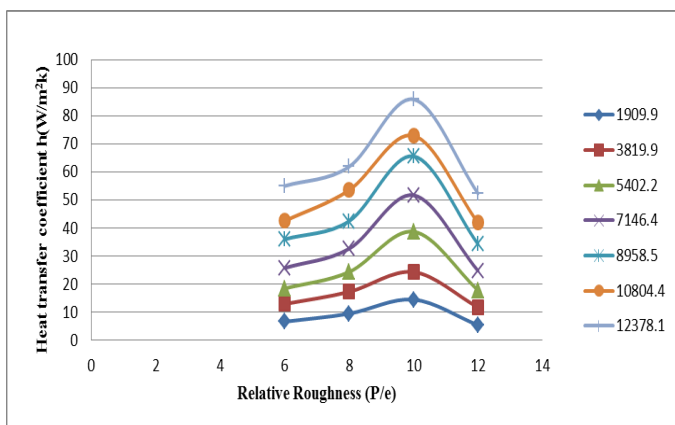

Fig. 5.3

5.4 Variation of Heat Transfer Coefficient with Reynolds Number

The variation of heat transfer coefficient with Reynolds number is shown in Fig. 5.4. It can be seen that the heat transfer coefficient increases with increase in Reynolds number for all cases due to increase in turbulence as the value of Reynolds number increases. For the constant value of Reynolds number, Nusselt for ribbed duct is higher than that of smooth duct because of presence of roughness elements in the form of square ribs; the intensity of turbulence is increased. Plot shows that maximum value for heat transfer coefficient is obtained for relative roughness pitch (p/e) of 10.

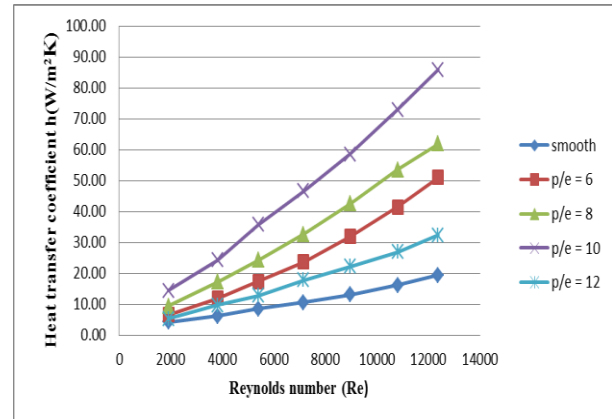

Fig. 5.4

5.5 Variation of Thermal Efficiency with Reynolds Number

Fig.5.5 shows the effect of Reynolds number on thermal efficiency. A separate characteristic has been shown for varying values of relative roughness pitch. The maximum value of efficiency is found at relative roughness pitch of 10. It is clearly understood that the thermal efficiency will depends on the difference of temperature between inlet and outlet of the duct. As the value of Reynolds number increases turbulence in the air flow increases thus more heat transfer takes place from absorber plate to air due to increases in turbulence at higher Reynolds number thus the thermal efficiency increases while at lower Reynolds number the efficiency is very low due to the presence of laminar sub layer which offer resistance to heat transfer from absorber plate to flowing air and hence lower thermal efficiency is observed.

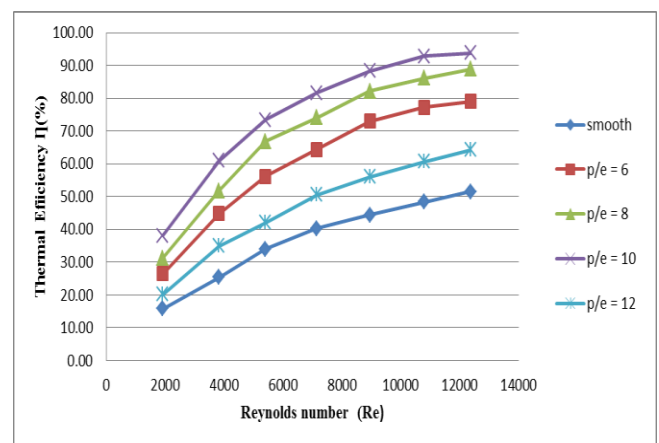

Fig. 5.5

5.6 Variation of friction factor with Reynolds number

The variation of friction factor with Reynolds number for the 90° inclined square ribs having the fixed value of relative roughness height (e/D_h) and angle of attack (α) for relative roughness pitch as a parameter is shown in Fig. 5.6. It can be seen that the friction factor decreases with an increase of Reynolds number. It is also observed that the friction factor decreases as the relative roughness pitch increases.

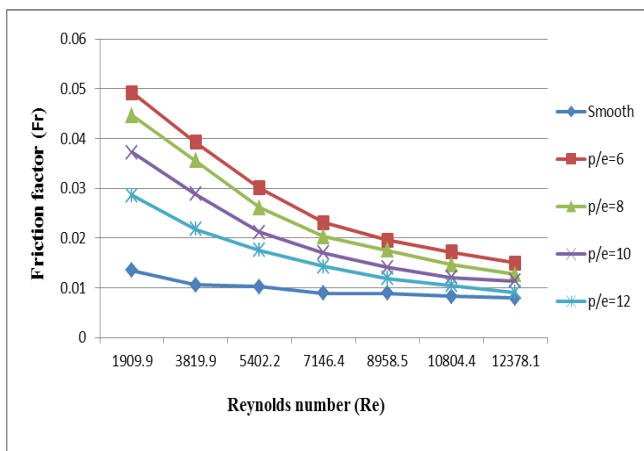

Fig. 5.6

6. CONCLUSION

The present research work was taken up with the objective of extensive investigation on square ribs as artificial roughness in discrete geometry on the underside of one broad wall of the of solar air heater duct for enhancement of heat transfer. The effect of relative roughness pitch on Nusselt number and Reynolds number has been investigated. The analytical expressions developed for heat transfer are based on the similarity considerations.

The following conclusions are drawn from this work:

1. In general, Nusselt number increases with an increase of Reynolds number. The values of Nusselt number is substantially higher as compared to those obtained for smooth absorber plates. This is due to distinct change in the fluid flow characteristics as a result of roughness that causes flow separations, reattachments and the generation of secondary flows.
2. The maximum enhancement of Nusselt number as a result of providing artificial roughness have been found to be 3.96 times that of smooth duct for an angle of

attack 90°. It appears that the flow separation and the secondary flow resulting from the presence of square ribs and the movement of resulting vortices combine to yield an optimum value of angle of attack.

3. It found that the Nusselt number increases with an increase of Reynolds number and attains maximum for relative roughness pitch of 10 and then decreases with an increases of relative roughness pitch. The variation of Nusselt number with relative roughness pitch (p/e) is in significant at lower values of Reynolds number, but at higher Reynolds number here is a substantial effect.
4. The maximum experimental thermal efficiency of two pass solar air heater has been found to be 93% at the relative roughness pitch of 10.
5. The following correlation have been developed for Nusselt number;

$$Nu_r = \{-0.1236 + 0.1221 \ln (p/e) - 0.0285 (\ln (p/e))^2\} Re^{1.0560}$$
6. It is also found that the variation of Friction factor with Reynolds number.

The analytical expression derived for heat transfer can be used for designing and predicting the performance of solar air collector with the artificial roughness providing on the absorber plate.

7. Nomenclature

- A_c surface area of absorber plate, m²
- B half-length of full V-rib element, m
- C_p specific heat of air, J/kg K
- D, Dh equivalent or hydraulic diameter of duct, m
- e rib height, m
- g groove position, m
- h heat transfer coefficient, W/m² K
- H depth of air duct, m
- I intensity of solar radiation, W/m²
- K thermal conductivity of air, W/m K
- L length of test section of duct or long way length of mesh, m
- m mass flow rate, kg/s
- P pitch, m
- DP pressure drop, Pa
- q_u useful heat flux, W/m²
- Q_u useful heat gain, W
- Q_l heat loss from collector, W
- Q_t heat loss from top of collector, W
- S length of discrete rib or short way length of mesh, m
- T_o fluid outlet temperature, K

T_i fluid inlet temperature, K
 T_a ambient temperature, K
 T_{pm} mean plate temperature, K
 W width of duct, m

Dimensionless parameters

$e/D, e/D_h$ relative roughness height
 e/H rib to channel height ratio
 f friction factor
 g/P relative groove position
 Nu Nusselt number
 N_{us} Nusselt number for smooth channel
 N_{ur} Nusselt number for rough channel
 p/e relative roughness pitch
 Pr Prandtl number
 Re Reynolds number
 St Stanton number
 W/H duct aspect ratio

Greek symbols

ϕ rib chamfer/wedge angle, degree
 η_{th} thermal efficiency
 μ dynamic viscosity, Ns/m^2
 ρ density of air, kg/m^3
 α angle of attack, degree

8. References

- [1] Aharwal KR, Gandhi BK, Saini JS. Experimental investigation on heat-transfer enhancement due to a gap in an inclined continuous rib arrangement in a rectangular duct of solar air heater. *Renew Energy*; 33:585–96[2008].
- [2] A. Lanjewar A, Bhagoria JL, Sarviya RM. Experimental study of augmented heat transfer and friction in solar air heater with different orientations of w-rib roughness. *Exp Therm Fluid Sci*; 35:986-95[2011].
- [3] ASHRAE standard 93–77. Method of testing to determine the thermal performance of solar collector [1977].
- [4] A.R. Jaurker, J.S. Saini, B.K. Gandhi, Heat transfer and friction characteristics of rectangular solar air heater duct using rib-grooved artificial roughness, *Solar Energy* (80) 895–907[2006].
- [5] Bhagoria JL, Saini JS, Solanki SC. Heat transfer coefficient and friction factor correlations for rectangular solar air heater duct having transverse wedge shaped rib roughness on the absorber plate. *Renew Energy*; 25:341–69[2002].
- [6] Duffie J. A. and Bechman, W.A., *Solar engineering of thermal processes*, Wiley, New York [1980].
- [7] Esen H. Experimental energy and exergy analysis of a double-flow solar air heater having different obstacles on absorber plates. *Building and Environment*; 43:1046e54[2008].
- [8] Gupta D, Solanki SC, Saini JS. Thermo hydraulic performance of solar air heaters with roughened absorber plates. *Solar Energy*; 61:33-42[1997].
- [9] Hahne E.W.P., Parameter effects on design and performance of flat-plate solar collectors, *solar energy*, 34, 497 – 504[1985].
- [10] Helmbold water, Independent house heating in temperature climate, *proc. Int. workshop on energy conservation in buildings*. CBRI, Roorkee, 33-40, April 2-7[1984].
- [11] J.S. Saini et. Al Heat transfer and friction factor correlations of solar air heater ducts artificially roughened with discrete V-down ribs. *Energy* 36,5053 e 5064 [2011].
- [12] Jain D, Jain RK. Performance evaluation of an inclined multi-pass solar air heater with in-built thermal storage on deep-bed drying application. *Journal of Food Engineering*; 65:497e509 [2004].
- [13] Karmare SV, Tikekar AN. Heat transfer and friction factor correlation for artificially roughened duct with metal grit ribs. *Int J Heat Mass Transf*; 50:4342–51[2007].
- [14] Karwa R, Solanki SC, Saini JS. Thermo-hydraulic performance of solar air heaters having integral chamfered rib roughness on absorber plates. *Energy*; 26:161–76[2001].
- [15] Karwa R. Experimental studies of augmented heat transfer and friction in asymmetrically heated rectangular ducts with ribs on the heated wall in transverse, inclined, v-continuous and v-discrete pattern. *Int Comm Heat Mass Transf*; 30(2):241–50[2003].
- [16] Kumar A, Bhagoria JL, Sarviya RM. Heat transfer enhancement in channel of solar air collector by using discrete w-shaped artificial roughened absorber International 19th national & 8th ISHMTASME heat and mass transfer conference [2008].
- [17] Kumar ST, Mittal V, Thakur NS, Kumar A. Heat transfer and friction factor correlations for rectangular solar air heater duct having 60° inclined continuous discrete

- rib arrangements. *Br J Appl Sci Technol*; 3:67-93[2011].
- [18] Lau SC, Kukreja RT, McMillin RD. Effects of V shaped rib arrays on turbulent heat transfer and friction of fully developed flow in a square channel. *Int J Heat Mass Transf*; 34:1605–16[1991].
- [19] Layek A, Saini JS, Solanki SC. Second law optimization of a solar air heater having chamfered rib-groove roughness on absorber plate. *Renew Energy*; 32:1967–80[2007].
- [20] Mohamad AA. High efficiency solar air heater. *Solar Energy*; 60:71e6 [1977].
- [21] Momin AME, Saini JS, Solanki SC. Heat transfer and friction in solar air heater duct with V-shaped rib roughness on absorber plate. *Int J Heat Mass Transf*; 45:3383–96[2002].
- [22] M.R.I. Ramadan, A.A. El-Sebaei, S. Aboul-Enein, E. El-Bialy. Thermal performance of a packed bed double-pass solar air heater. *Energy* 32 1524–1535[2007].
- [23] Ozgen F, Esen M, Esen H. Experimental investigation of thermal performance of a double-flow solar air heater having aluminium cans. *Renewable Energy*; 34:2391e8 [2009].
- [24] Prasad BN, Saini JS. Effect of artificial roughness on heat transfer and friction factor in a solar air heater. *Sol Energy*; 41(6):555–60[1988].
- [25] Prasad SB, Saini JS, Singh KM. Investigation of heat transfer and friction characteristics of packed bed solar air heater using wire mesh as packing material. *Solar Energy*; 83:773e83 [2009].
- [26] Parsad P, Satcunanathan S. The thermal performance of the two passes. *Two GlassCover Solar Air Heater. J Sol Energy Eng*; 105(3):254[1983].
- [27] Sahu MM, Bhagoria JL. Augmentation of heat transfer coefficient by using 90° broken transverse ribs on absorber plate of solar air heater. *Renew Energy*; 30:2057–63[2005].
- [28] Saini RP, Verma J. Heat transfer and friction factor correlations for a duct having dimple-shape artificial roughness for solar air heaters. *Energy*; 33:1277–87[2008].
- [29] Satcunanathan, S. Deonarine. A two pass solar air heater. *Solar Energy*, 15, 41[1973].
- [30] Thombre, S.B., Sukhatme,S.P. Turbulent flow heat transfer and friction factor characteristics of Shrouded fin arrays with uninterrupted fins. *Experimental Thermal and Fluid Science*,10,388[1995].
- [31] Varun, Saini RP, Singal SK. Investigation of thermal performance of solar air heater having roughness elements as a combination of inclined and transverse ribs on the absorber plate. *Renew Energy*; 33:1398–405[2008].
- [32] Wijesundera NE, Ah LL, Tjioe LE. Thermal performance study of two-pass solar air heaters. *Sol Energy*;28(5):363–70[1982].
- [33]. Chaube Alok, Sahoo P.K., Solanki S.C. (2004) “Computational analysis of heat transfer enhancement due to rectangular ribs in a turbulent duct flow” 5th Bi- annual ASME-JSME international conference at San Diego, united states on 25-07-04.
- [34]. Chaube Alok, Sahoo P.K., Solanki S.C. (2003) “Computational investigation of heat transfer and flow field characteristics in 2D Rib roughened rectangular duct “ paper presented in fluent international CFD conference at Pune (India).
- [35]. Chaube Alok, Sahoo P.K., Solanki S.C. (2003) “Analysis of heat transfer enhancement due to artificial roughness” ISME conference at IIT Roorkee (India).
- [36]. Chaube Alok, Sahoo P.K., Solanki S.C.(2005) “Analysis of heat transfer augmentation and flow characteristic due to Rib roughness over absorber plate of a solar air heater”. *Journal of Renewable energy pergamon press*.
- [37]. Chaube Alok, Sahoo P.K., Solanki S.C. (2005) “Effect of roughness shape on heat transfer and flow friction characteristics of solar air heater with roughened absorber plate”. *International solar energy conference, florida USA in Aug 2005*.
- [38]. ankur vishwakarma, Dr. A. R. Jaurker *Experimental Investigation for Enhancement of Heat Transfer in Double Pass Solar Air Heater Using Transverse Discrete Rib Geometry IJETED Issue 4, Vol.4 (June-July 2014) ISSN 2249-6149*