

# Experimental Study on Concrete Pressure in Slipform Panels.

Vinothkumar.V<sup>1</sup>, Jaisankar.G<sup>2</sup>

<sup>1</sup>PG Student, Department of Civil engineering, Dr.Mahalingam College of Engineering and technology, Coimbatore-642003, India

<sup>2</sup> Professor & Head, Department of Civil engineering, Dr.Mahalingam College of Engineering and technology, Coimbatore, 642003, India

Email: <sup>1</sup>vinothkumarvsamy@gmail.com, <sup>2</sup> hod\_civil@drmcet.in

□

**Abstract**—Slipform is a construction method that has been used for developing concrete structures. When compared to normal type of construction, the proposed method will be helpful in reducing the time taken for the completion of the project. Slipform is a continuous process which requires pre-planning, supply of construction materials, without any time lag and material lag. This proposed method is preferred for circular structure for buildings of greater height, for non circular structures damages occurred on panel surfaces which leads to the repair works of the slipform, which in turns affect the economical criterion in the slipform construction method. Slipform technique is used successfully in minor works without any damages whereas in some other cases, surface damages have occurred during Slipforming operation. Among the damages the most typical damages are cracks during lifting and vertical lined damages. When concrete is poured into the formwork panel, there exerts pressure on the formwork panel by the concrete. As a result of the pressure the panel gets cracks or damaged, initially the pressure intensity exerted will be maximum at the fresh state when compared to the harden state of concrete. The prime objective of the paper is to experimentally determine the lateral pressure that is exerted by the concrete on the panel. In here the lateral pressure exerted by concrete on the panel is by sensed using pressure sensors. The experimental work carried out for different grade of concrete and compared with each other. A graph is plotted between time and pressure in order to correlate the results obtained. This experimental work will helpful to improve the quality of slipform construction by reducing the damages upon the slipform panel.

**Keywords:** Lateral pressure, Pressure calculation, Sensors.

## I. INTRODUCTION

Slipform is a construction method that has been used in several decades for high raised buildings. It is wide range of different structures that are vertical structures such as towers, bridge columns and offshore platforms. Slipforming are not only used for straight vertical concrete structures, but also on structures where the geometry of the structure and wall thickness is changed. Slip-forming is a continuously poured,

Continuously formed construction method in which concrete is poured in continuously moving form. Slip-forming enables continuous, non-interrupted, cast-in place flawless concrete Structures which have the superior performance characteristics to piecewise construction using discrete form elements. Slipforming technique differs from conventional concrete forming because of forming panels that move semi continuously in relation to the concrete surface being formed. This technique proved to be the valuable tool in cutting cost and man hours and the same time permitting construction to proceed with maximum safety.

The Slipform was introduced in the early 1900 to construct tall and slender structures. It was made from timber and used with hand operated screw jacks, later the screw jacks are replaced by mechanical/hydraulic jacks. The slipform served as the best forming solution for building silos and grain elevators, etc., throughout the world but was introduced to residential and commercial high rise buildings in North America only in the late 1960.

In India, only during the late 1970, this technique was incorporated in the construction of tall structures especially for the construction of cooling towers in thermal and nuclear power stations. The formwork system uses a 1.06 m high steel panel

which is held rigid with a steel framework. There are strategically placed yoke units. Attached in the yoke units are hydraulic climbing jacks which are passed through by black mild steel rods.

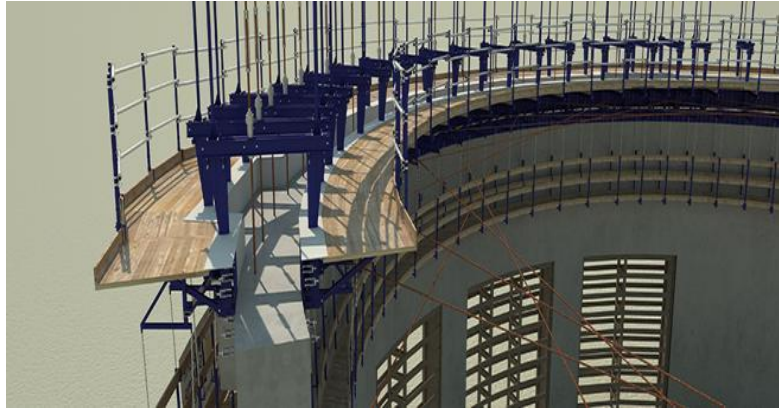

**Fig 1: Slipform structure**

## II. EXPERIMENTAL SETUP

The purpose of the experimental program is to carryout tests in order to investigate and possibly verify the research program. In experimental investigation, the lateral pressure from concrete over the formwork calculated. Pressure varies at different levels, Pressure will be maximum in the liquid phase, minimum in the harden phase. In this Experimental investigation the pressure sensors placed in at the different heights in the panels, in order to calculate pressure at the different height of the panel.

### A. *Steel Panel*



**Fig 2: Steel Panel**

The figure.2 shows the Steel panel fabrication work for Experimental investigation. The steel panel has size about 500mm length, 300mm width, 3mm thickness with 1000mm height. The panel is connected with L-angle on four sides which dimensions of about 50mmx50mmx6mm.

**B. Pressure Sensor**

Pressure sensor measures Pressure acting on formwork. Pressure sensor usually act as a transducer its generates a signal as a function of pressure imposed. Pressure sensor is used for control and monitoring in thousands of everyday applications. Pressure sensor can also be used to indirectly measure other variables such as fluid flow, water level. Pressure sensor alternatively called Pressure transmitter, Pressure transducer.

The lateral pressure exerted by concrete can be measured by using force sensing resistor which shown in figure.3, which is operable over -30 to 120°C. The sensors are connected to Data acquisition system of relatively low scanning voltage up to 5V. The figure.3 shows the pressure sensor used for experimental setup.



**Fig 3: Pressure Sensor**

This pressure sensor is named as “Force Sen with a square shaped size about 40mmx40mm. The Force sensing resistor can sense applied force anywhere in the range of 100g-10kg, two pins extended from the bottom of the sensor with 0.1” pitch making

There is a peel-and-stick rubber backing on the other side of the sensing area to mount the FSR. The pressure sensing area

is 1.75”x1.5”, this sensor will upon how much pressure is being applied to the sensing area.

Pressure sensitivity range of this sensor lies between 1.5psi to 150psi, life time is more than 10 million actuations.

**C. Data Acquisition**

Data acquisition is the process of sampling signals that measure real world physical conditions and converting the resulting samples into digital numerical values that can be manipulated by a computer. By using this Data acquisition maximum number of input chases is connected. The components of the Data acquisition system which includes sensor converts physical parameter to electric signals, signal conditioning circuitry to convert sensor signals into a form that can be converted to digital values. In this proposed work Data acquisition is used to connect with the pressure sensor in order to calculate the pressure acting on the panels.



**Fig 4: Data Acquisition system**

The figure.4 shows the Data acquisition system which is used for experimental investigation. In this work National instruments cDAQ9188 data acquisition system is used with NI9124 type of measurement chases for experimental setup. Then the zero networking configuration is done by NI compact disc program.

**D. Signal Conditioning**

The signal condition can be done by using four resistors which is 1kohm on four sides correspondingly. Input voltage is limited to 0-5v. In signal condition program the input and output are connected to NI chases correspondingly same as the connection diagram. The IC trainer kit used for the signal conditioning process, in which resistors are connected to the trainer kit along with the NI DAQ 9234 monitoring system.

In signal conditioning program the input range is up to 5V, the wheat stone bridge is made of using four resistors with range of 720kohm, which is connected to instrumentation amplifier, the end of the circuit is connected to the DAQ card which gives the results of the signals as the connection diagram as shown in the figure.5.

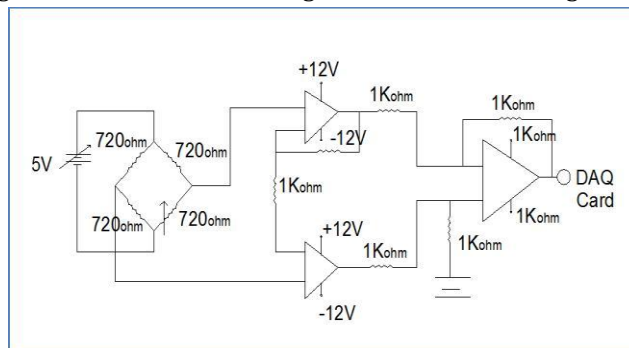

**Fig 5: Signal conditioning program**

**E. Software used**

LabVIEW software is used for the Experimental investigation. LabVIEW (Laboratory Virtual Instrument Engineering and Workbench) is a system design platform and development environment for a visual programming language from National instruments. LabVIEW software is very helpful for monitoring the pressure values from National instrument cDAQ-9188. Before using LabVIEW software the system connected with NIDAQ max.

Initially Data acquisition system IP address are configured with the computer which is used for the experimental investigation. Programming is done by using LabVIEW software, for that initially DAQ assistant property is assigned with 0-5V range with maximum number of samples. The signals are acquired as a voltage from DAQ assistant and that voltage will be

converted as a pressure. Programming is done for all the sensor connections, for each sensor the numerical and graphic indicators fixed in the program. The program is done on the basis of the pressure sensor sensitivity and force sensitivity ranges.

The graphic indicator results which are stored in a database in the form of Microsoft Excel program which is taken for every minute. When the program is executed the data will be automatically records its values in the database until the program stops. The results can be obtained at every second depending upon the interval time as fixed in the LabVIEW program and corresponding results will be displayed. The LabVIEW program is shown in figure.6.

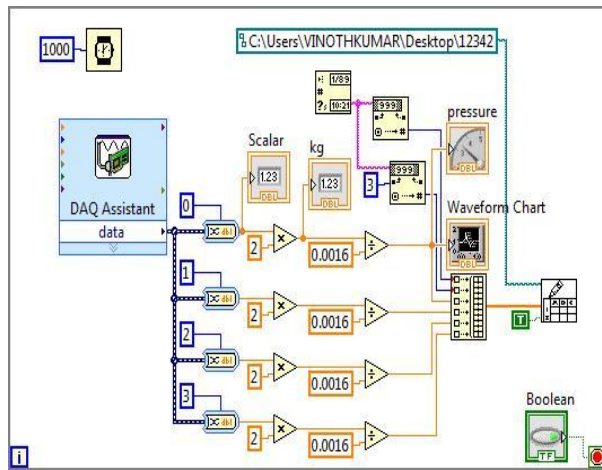

**Fig 6: LabVIEW Program**

**F. Testing of sensor**

Sensor tested at different methods, at first the sensors are tested whether it is workable with fluids or not. Thereby the sensor is dipped in to the water and checked for the variation of the results. Secondly sensor is fixed in to the cube mould when the concrete is poured in to the mould, for checking the results variation of the sensors in concrete.

Also the sensors tested by manually applying the load in to the sensing area of pressure transducer which results will be taken for every weight applied up to the 5kg and checked for the linearization of the sensor. The corresponding loads applied only into the sensing area of the sensor.



**FIG 7: TESTING OF SENSOR**

The figure.7 shows the testing of sensor by manually applying the load. The results taken for every applied and removed load, is checked for the values which are similar for applied and removal of weights. After getting the results the values are

checked for the linearization with corresponding to the weights. The sensor linearization will be helpful for finding out the pressure calculation. In here the load test is done by two methods, first the weight is applied directly to the sensor and second one the sensor was covered by the sheet metal then the load is applied.



The figure.8, which shows the graph between the load against the resistance, the results shows that graph is linear by the testing of sensors for manually applied the load into the sensor directly.

### III. EXPERIMENTAL PROGRAM

#### A. Placing of the Sensor

The sensors are placed at the different heights of the panel for calculating the different pressure levels. In here four sensor were used for either side of the panels.

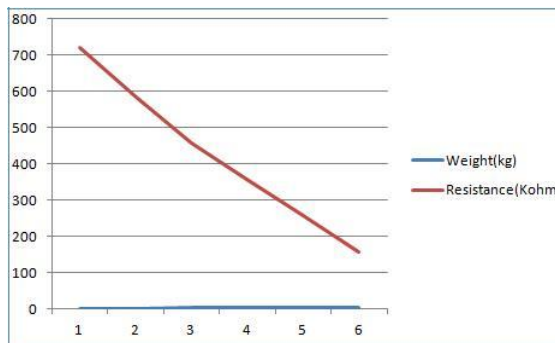

Fig 9: Placing of sensor

Sensors are completely protected in order to resist the damages from the concrete, four sensors placed parallel as shown in figure.9, similarly the four sensor were placed on the shorter side of the panel. The sensors are placed at the height of 0mm, 250mm, 500mm & 750mm from the bottom of the panel for both longer and shorter side of panel.

**B. Concrete**

The process of selecting suitable ingredients of concrete and determining their relative amounts with the objective of producing a concrete of the required, strength, durability, and workability as economically as possible, is termed the concrete mix design. The following mix ratios used for the concrete works.



**Fig 11. Concrete work**

The figure.11, refers the Experimental arrangement of the testing work, here the Data acquisition system is connected to the signal conditioning program for calculating the lateral pressure on the panel by concrete. By using the design mix, the concrete was mixed by using high quality with well graded materials. In concrete the slump value is taken as 85mm. After the concrete started to pour in to the panels, the sensors starts to monitor the pressure values. In this Experimental work here four sensors used in two sides. The concrete was poured in each layer by layer and its well compacted. Initially the sensor which is placed at the bottom of the panels produces higher value of pressure, correspondingly the other sensors produces the pressure value which corresponds to the concrete acting on the sensor. By adopting the graphic indicator for the four sensors we can check whether the sensors working or not at the time of the concrete.

The readings are taken up to 10 hours, by using of the LabVIEW software, it can get the pressure acting on the panels for every minute itself. We can change the time duration of the results for our convenience. The result will be recorded in to the data base which was programmed already.

After completion of the final setting time of the concrete, the sensors were removed from the formwork safely for the purpose of the reusing of sensors. Before to reuse, the sensor should be calibrated again whether is in working condition or damaged

**IV. RESULTS**

The development of concrete pressure as a function of time is plotted in Graph 1., Measurements taken over a period of 10 hours from beginning at the start of concrete in to the panels. The test results for the M30&M40 grade of concrete is shown in graph1,graph 2. In this Experimental investigation for the M30 & M40 grade concrete the pressure was maximum at the bottom compared to the top of the concrete for both M30&M40 grade. After started the concrete up to the 5th hour pressure value is increased then the pressure value will be reduced due to the hardening of the concrete The below graph which refers the pressure against with the time in Minutes.

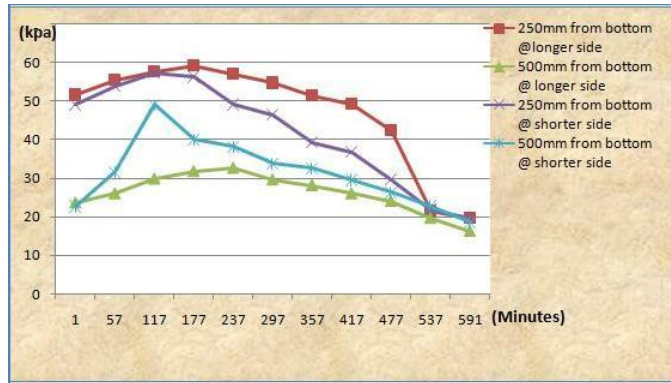

Graph 1: M30 Test results

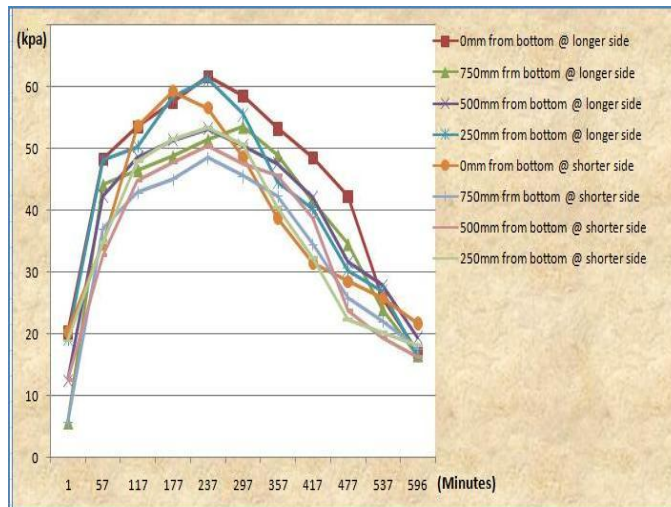

Graph 2: M40 Test results

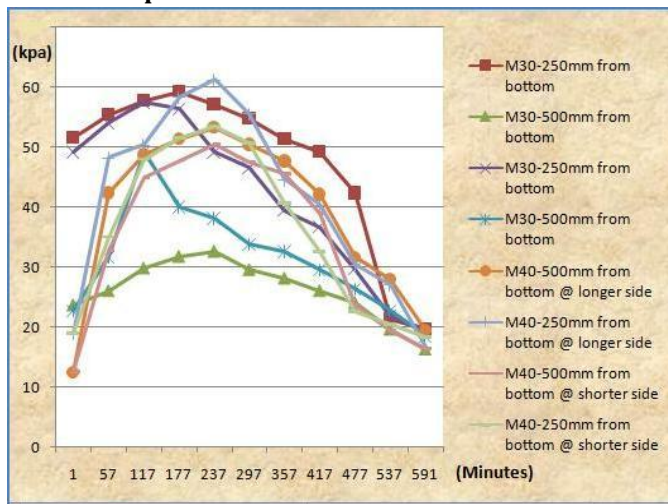

Graph 3: Comparison of M30 & M40



From the graph.3, the results between M30 and M 40 grade of concrete are compared at the height of 250mm, 500mm for both shorter and longer side of the panel respectively. From the observation it is clear that the pressure exerted by M40 grade of concrete at 250 mm height from bottom at longer side of the panel is higher when compared to M30 grade of concrete of similar side and height. When the pressure is compared on the whole, in M 40 grade of concrete at 0mm height of the panel gives maximum pressure.

## V. CONCLUSION

On Experimental program, the different pressure values obtained depends different height of the panels. From the Experimental investigation, the M40 grade concrete produces the maximum pressure when compared to the M30 grade of concrete. In generally M40 grade of concrete contains maximum cement content with high flow able property compare to M30 grade. So the pressure values maximum at the M40 grade of concrete. Similar work done for the M50 grade of concrete, and finally will be compared the different grades together. This result of proposed system reflects a good improvement in reducing damages in slipform panels.

## VI. REFERENCE

- [1] Kjell Tore Fossa and Dr.I of Vertical Concrete Structures, Friction between concrete and slip form Department panel”,of Structural Engineering, The Norwegian University of Science and Technology.
- [2] Talesnic,Katz“Measure Lateral Pressure On Concrete ”, Department of Civil Engineering, Isrel Institute of technology, Haifa 32000,Isrel.
- [3] Puente.I,santilli.A,Lopez.A,”Lateral pressure over formwork on large dimension co Civil Engineering, Tecnum(University of Navarra),Spain.
- [4] Camellerie, P.E.” Vertical Slipformi tool”,EbascoServices Inc. New York, New York.
- [5] Fossa Aker Kvaerner.K.T,”Slip forming of advanced concrete structures”,Moksnes Consulting, Norway.
- [6] Betterham, R. G. (1980). Slipform concrete, New York.
- [7] Ramesh Kannan , Helen Sant Assessment of Climbing Formwork Systems Using Building Information Modeling”, Depart School of Mechanical and Building Sciences, VIT Chennai.
- [8] Jaafari, A., Kew, Y. C., and Yeoh, C. K. (1989). ‘Alternative methods formed- cons concrete structures.’ Institut
- [9] Reichverger, Z., Jaegermann C. (1982) ‘Frictio pressure of concrete in slip-form concreting’ International Sur le beton, Jevne, Paris, 6-8 April 1982.
- [10] Tarek Zayed, M. Reza Sharifi, Sandel Baciu, Mohamed Amer (2008) ‘Journal of Cons Management’l.134,No . 3,VoMarch 1, 2008.
- [11] A.Santilli, M.Tanco (2010) determine the significant parameters of fresh concrete lateral pressure and initial rate of engineering,uruguay.
- [12] Kamal H Khayat , Joseph ‘Measure determining formwork pressure of highly-flowable conc missouri university in 2008.
- [13] Sathyabhama.P and Jaisankar.G (2014)”Analytic investigation of vertical sli National conference on Recent advances in Structural Engineering,(RAISE’14).