

# Single-Controllable-Switch-Based Switched Reluctance Motor Drive.

Varade A.S<sup>1</sup>, Pande A.S<sup>2</sup>, Aher S.J<sup>3</sup>

<sup>1,2,3</sup>Assistant Professor, Dept of EE,AVCOE Sangamner, Maharashtra,India<sup>1</sup>

**ABSTRACT** -The Switched Reluctance Motor is a simple structure, ruggedness, and inexpensive manufacturing capability. The conventional power converter for Switched Reluctance Motor Drive requiring two switches per phase in this case study single switch is required per phase and its MATLAB simulation is done. This new drive system retain the unique feature of self starting for all rotor position. Simulation result based on non-linear model of the motor drive system, due to the single switch used cost of the drive is low and losses also minimized. This new drive system take attention due to its lowest cost structure ,packaging compactness, self-starting feature, variable-speed operation, fault tolerant tendency. Because of these merits, the new drive system offers a viable alternative for conventional drive. It is used in fan, blowers, hand tool, home appliances.

**Key Words:**Switched Reluctance Motor, Power converter, Asymmetric bridge converter, Single Switch Power Converter, MATLAB Simulation.

## I. INTRODUCTION

The electrical drive are very important part of an industry. The requirement of drive depends on the available supply and load characteristics. Among the electrical machine drives such as induction motor drive, DC motor and PMSM drive, switched reluctance motor drive are growing rapidly in numbers. As growing energy and environmental concern have increased demand for variable speed in low cost drive.

The switched reluctance motor is known to be the lowest cost motor with the simplest construction having no brushes, commutator, winding or magnet on rotor and only concentrated winding on its stator. In last few years the SRM have gain increasing attention since they offer the possibility of electric drives which are mechanically and electrically more rugged than those build up around the conventional AC and DC motors. In case of SRM drive, the technical superiority of the AC drive is obtained or even enhanced at a very low cost. In order to get performance oriented Drive, The accurate modeling of a Motor is to be done. The performance of machine can be checked with the help of Matlab / Simulink. This helps to design the Controller for the motor.

Power converter for the switched reluctance motor has number of configuration available such as q, (q+1), 1.5q, 2q switch configuration, where as q is the

number of machine phases. The switched reluctance motor drives always have a phase winding series with switch. The phases of switched reluctance motor are independent and in case of failure, uninterrupted operation of the motor drive operation is possible although with reduced power output. Single switch per phase converter are appealing due to their compactness of converter package and hence a possible reduction in their cost compared to other converter.

## II. SWITCHE RELUCTANCE MOTOR

### A. Construction

The physical appearance of a Switched Reluctance motor is similar to that of other rotating motors (AC and DC) Induction Motor, DC motor etc. The construction of 6/4 (6stator poles, 4 rotor poles) poles SRM is shown in Figure1. It has doubly salient construction. Usually the number of stator and rotor poles is even. The windings of Switched Reluctance Motor are simpler than those of other types of motor. . There is winding only on stator poles, simply wound on it and no winding on rotor poles. The winding of opposite poles is connected in series or in parallel forming no of phases exactly half of the number of stator poles. Therefore excitation of single phase excites two stator poles. The rotor has simple laminated salient pole structure without winding. This is the advantage of this motor as it reduces copper loss in rotor winding. The stampings are made preferably of silicon steel, especially in higher efficiency applications. For aerospace application the rotor is operating at very high speed, for that cobalt, iron and variants are used.

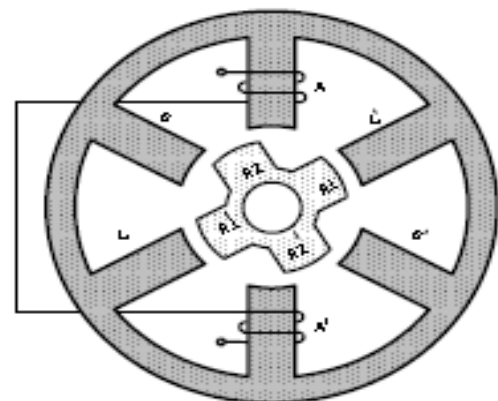

Fig 1: Cross section of three phases SRM.

The air gap is kept as minimum as possible, especially 0.1 to 0.3mm. The rotor and stator pole arc should be approximately the same. If the rotor pole arc is larger than the stator pole arc it is more advantageous.

**B. Mathematical model.**

In order to make a mathematical model for this motor, the equation is the applied voltage to a phase which is the sum of the resistive voltage drop, the derivative of the flux linkages as a function of the rotor position and the current.

Voltage equation of every particular phase as,

$$V = r i + d\psi / dt \quad \dots(1)$$

$$\text{Where, } \psi = Li = N\phi \quad \dots(2)$$

$r$  = winding resistance

$L$  = Nonlinear equivalent inductance

$$V = r i + L di/dt + i (dL/d\theta) (d\theta/dt) \quad \dots(3)$$

$$V = r i + L di/dt + i \omega (dL/d\theta) \quad \dots(4)$$

In this equation, the three terms on the right-hand side represent the resistive voltage drop, inductive voltage drop, and induced emf, respectively.

**C. Development of torque.**

The torque production in switched reluctance motor comes from the tendency of the rotor poles to align with the excited stator poles. The rotor is aligned whenever diametrically opposite stator poles are excited. In a magnetic circuit, the rotating member prefers to come to the minimum reluctance position at the instance of excitation. While two rotor poles are aligned to the two stator poles, another set of rotor poles is out of alignment with respect to a different set of stator poles. Then, this set of stator poles is excited to bring the rotor poles into alignment. Likewise, by sequentially switching the currents into the stator windings, the rotor is rotated. The movement of the rotor, hence the production of torque and power, involves switching of currents into stator windings when there is a variation of reluctance; therefore, this variable speed motor drive is referred to as a switched reluctance motor drive.

The general expression for the torque produced by one phase at any rotor position is,

$$Td = [\delta W / \delta\theta] i = \text{Const} \quad \dots(5)$$

$$\text{Since } W = \text{Co-energy} = 1/2 F \phi = 1/2N I\phi \quad \dots(6)$$

This equation shows that input electrical power partly increases the stored magnetic energy ( $1/2L*i^2$ ) and partly provides mechanical output power ( $i^2/2 \times dL/d\theta \times \omega$ ), the latter being associated with the rotational e.m.f. in the stator circuit. Neglecting saturation non-linearity

$$L = \text{Inductance} = N\Phi / I \quad \dots(7)$$

$$Td = 1/2 i^2 dL/d\theta \quad \dots(8)$$

This equation shows that the developed torque is independent of direction of current but only depends on magnitude of current & direction of  $dL/d\theta$

$$Te = \sum Ni = 1 \quad Td = TL + B\omega + Jd\omega/dt$$

Where,  $Te$  is the sum of the torque developed by all Phases,  $N$  is the number of phases, and  $J$  and  $B$  denote the

total inertia moment and the total damping ratio respectively.

**III. POWER CONVERTER**

The selection of converter topology for a certain application is an important issue. Basically, the SRM converter has some requirements, such as:

- 1) Each phase of the SR motor should be able to conduct independently of the other phases. It means that one phase has at least one switch for motor operation.
- 2) The converter should be able to demagnetize the phase before it steps into the regenerating region. If the machine is operating as a motor, it should be able to excite the phase before it enters the generating region. In order to improve the performance, such as higher efficiency, faster excitation time, fast demagnetization, high power, fault tolerance etc.
- 3) The converter should be able to allow phase overlap control.
- 4) The converter should be able to utilize the demagnetization energy from the outgoing phase in a useful way by either feeding it back to the source (DC-link capacitor).
- 5) In order to make the commutation period small the converter should generate a sufficiently high negative voltage for the outgoing phase to reduce demagnetization time.
- 6) The converter should be able freewheel during the chopping period to reduce the switching frequency. So the switching loss and hysteresis loss may be reduced.
- 7) The converter should be able to support high positive excitation voltage for building up a higher phase current, which may improve the output power of motor.

**A. Single Controllable switch Converter.**

This all requirement full feel by single switched controllable converter.

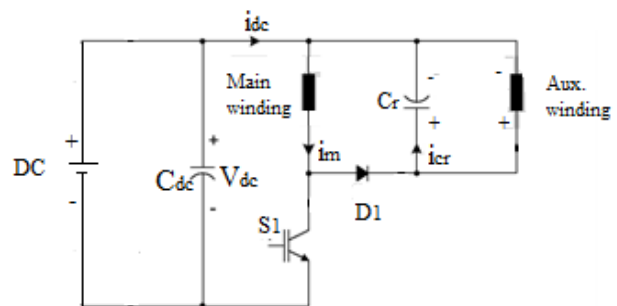

Fig 2 : Single controllable switch converter.

The single switch controllable converter shown in Figure 2. has only one controllable switch and one diode, making the drive electronics very compact and inexpensive. The key features of the converter are:

- 1) Filter capacitor  $C_{dc}$  forms a dc link to supply energy to the main phase winding.
- 2) Isolation for the gate drive circuit can be avoided since the switch  $S_1$  is tied with the negative dc link.
- 3) The converters are inherently suited for two-phase SRMs having asymmetric stator phases to realize self-starting as well as speed reversal.
- 4) The recovery capacitor,  $C_r$  along with the auxiliary winding, is for handling recovery energy from the main phase. During the commutation of the main phase current, the current flows to charge  $C_r$  and to a small extent goes through the auxiliary winding.
- 5) In the conventional converters, the recovered energy stored in the capacitor  $C_r$  is returned back to the dc link capacitor and this energy exchange between the motor and source causes extra losses leading to a larger dc link capacitor and active devices' rating. In the new converter, however, the recovered energy is retained and utilized within the motor windings instead of being returned to the source.

The working of this converter explained as following in five modes.

**Mode 1:** When the switch  $S_1$  is turned on, the main winding is energized with energy from the dc link. The auxiliary winding is also energized from the capacitor  $C_r$  if there is a charge in  $C_r$ .

**Mode 2:** When  $S_1$  is still turned on, the main winding continues to be energized. If  $C_r$  is completely discharged, then there is no current flow between  $C_r$  and the auxiliary winding.

**Mode 3:** When  $S_1$  is turned off, the current in main winding flows through  $D_1$  and  $C_r$  as well as the auxiliary phase, hence transferring energy in part to  $C_r$  and in part to auxiliary winding.

**Mode 4:** When  $S_1$  is turned off, both the main winding current and  $C_r$  supply the auxiliary winding.

**Mode 5:** When the switch  $S_1$  is turned off and the main winding is successfully commutated, and  $C_r$  exclusively supplies the auxiliary winding current.

### B. Asymmetric Bridge Converter.

Figure 3 shows the asymmetric bridge converter considering only one phase of the SRM. The rest of the phases are similarly connected. Turning on transistors  $T_1$  and  $T_2$  will circulate a current in phase A of the SRM. If the current rises above the commanded value,  $T_1$  and  $T_2$  are turned off. The energy stored in the motor winding of phase A will keep the current in the same direction until it is depleted. Hence, diodes  $D_1$  and  $D_2$  will become forward biased leading to recharging of the source. That will decrease the current, rapidly bringing it below the commanded value. During the positive inductance slope

for motoring action, the A-phase current command is generated with a linear inductance profile.

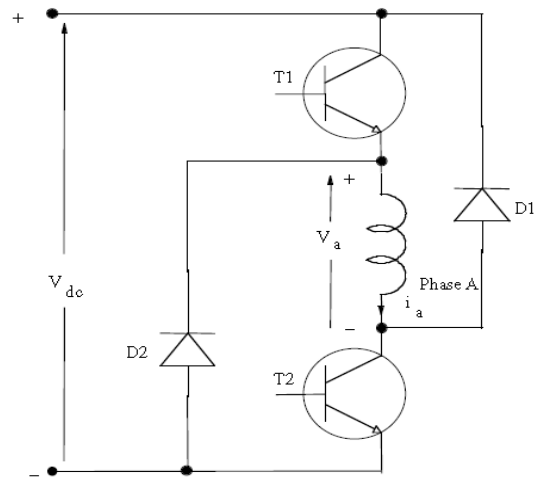

Fig. 3: Asymmetric bridge converter

TABLE I. Comparison of new converter with conventional converter .

Criteria	Asymmetric bridge converter	Single controllable switch converter
No. of power Switches	2	1
No. of diodes	2	1
No. of gate drives	2	1
No. of power supplies for isolated gate drivers (min)	2	1
Switch voltage rating (min)	$V_{dc}$	$2V_{dc}$
Switch current rating (peak)	$I_p$	$I_p$
Switch conduction losses	$2dsI_p$	$dsI_p$
Diode conduction losses	$2(1-ds)I_p$	$(1-ds)I_p$
Recovery capacitor rating	1	0.5

Note:  $I_p$  is the peak rated motor phase current and  $ds$  is the switch duty ratio.

The comparison of the new single-switch converter with the conventional asymmetric bridge converter for driving a single-phase machine is summarized in Table I. The comparison is made in terms of the component count, device ratings, and losses.

### IV. MODELING OF SRM

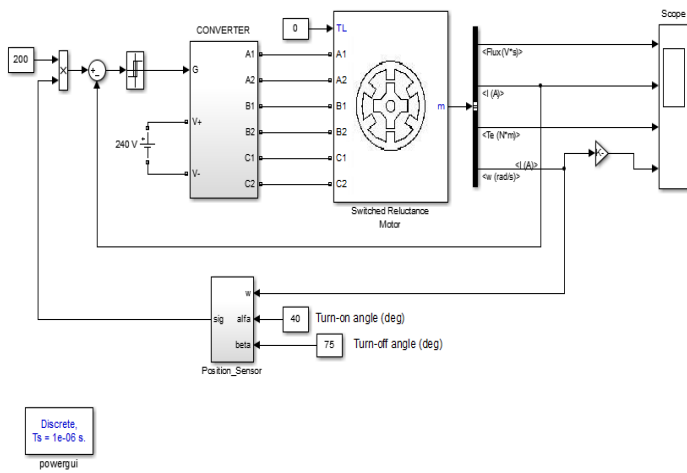

Fig 4: MATLAB model of Switched Reluctance Motor Drive.

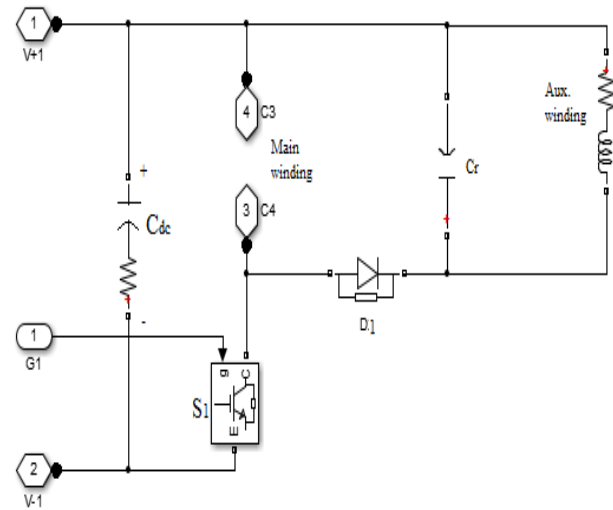

Fig 6: Sub system of single switch converter for one phase of motor

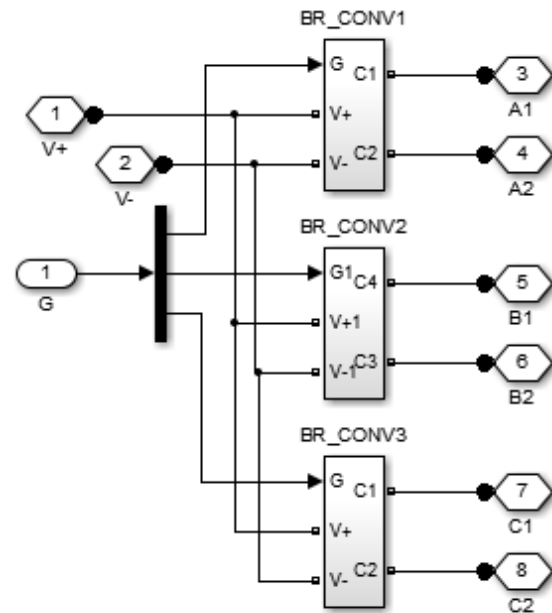

Fig 5: Subsystem of the Converter.

The whole model is divided into several independent block, such as position sensor block, converter block, switched reluctance motor block. Converter block contain the separate three, single switch converter. SRM 6/4 model used in this simulation.

The function of position sensor block is to work out the angle of rotor position angle relative to reference zero angle in an electric cycle. For a 3-phase 6/4 SRM, each phase inductance has a periodicity of 90 degrees. Therefore, it is appropriate to transform the rotor position angle coming from the mechanical equation so that it is modulo 90. Here, modulo 90 is realized by virtue of rem function.

An Single switch converter is adopted here, it's function is implemented by using MATLAB/SIMULINK. The simulation model of converter block for one phase is shown as Figure 4.2. It has one power switches and one diodes .Step motion of Switched Reluctance Motor is realized by switching on or off phase windings. The choosing of conduction angle is crucial to the power and torque ripple of SRM

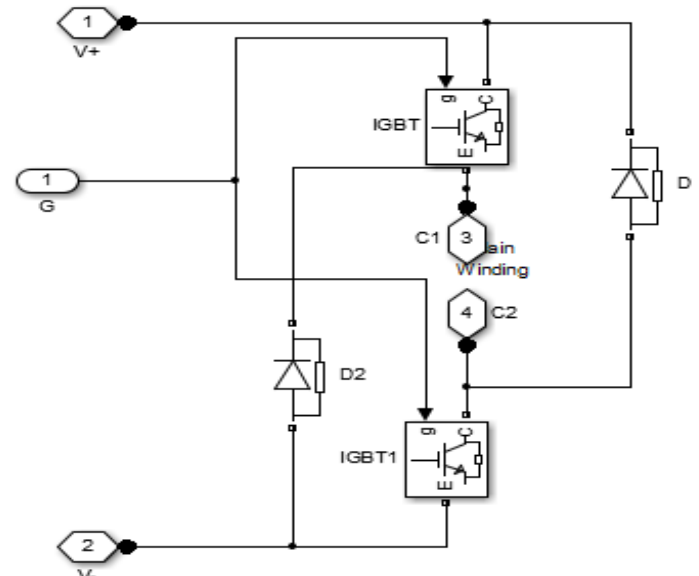

Fig 7: Sub system of Asymmetric Bridge Converter for one phase

An Asymmetric bridge converter is adopted here, it's function is implemented by using MATLAB/SIMULINK. The simulation model of converter block for one phase is shown.

## V. SIMULATION RESULT

### A. Single Switch Converter.

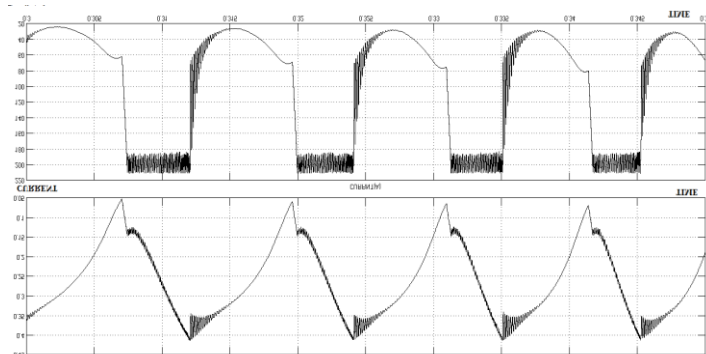

Fig 8: Flux and Current variation of one phase of SRM

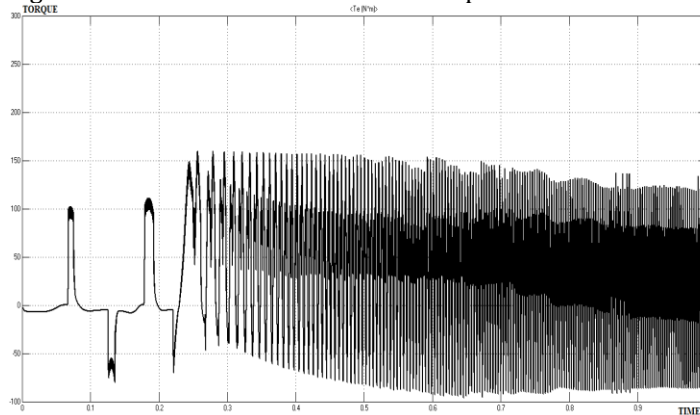

Fig 9: Torque Characteristics of SRM

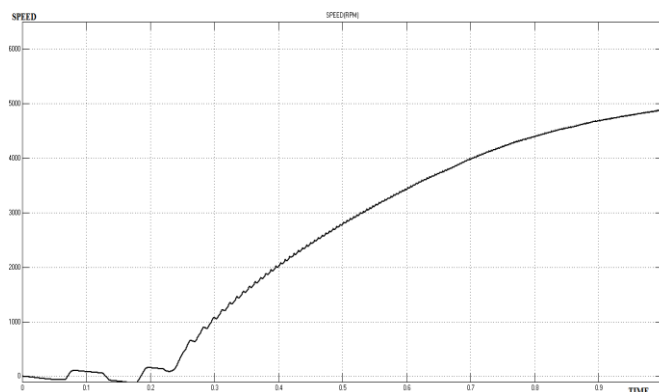

Fig 10: Speed characteristic of SRM.

### B. Asymmetric Bridge Converter.

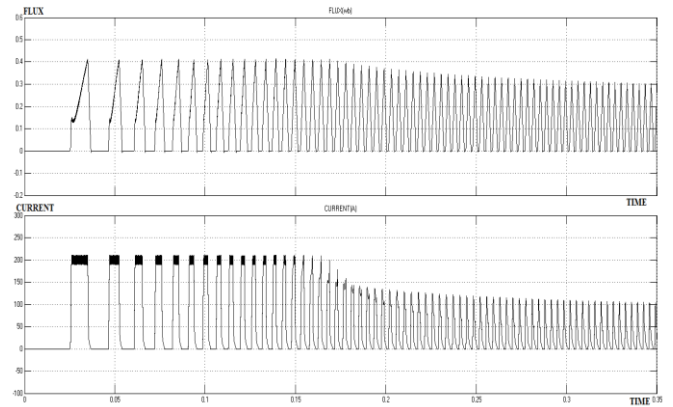

Fig 11: Flux and Current Variation for one phase

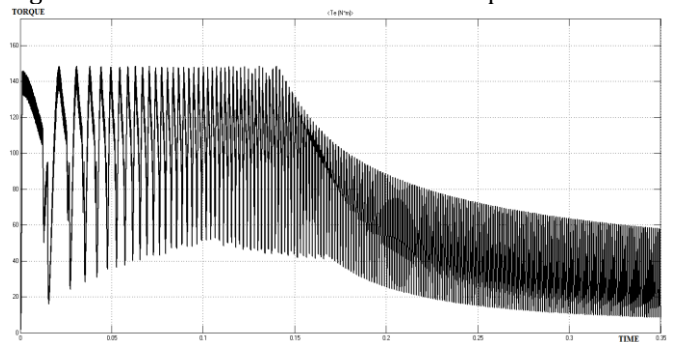

Fig 12: Torque Characteristics of SRM

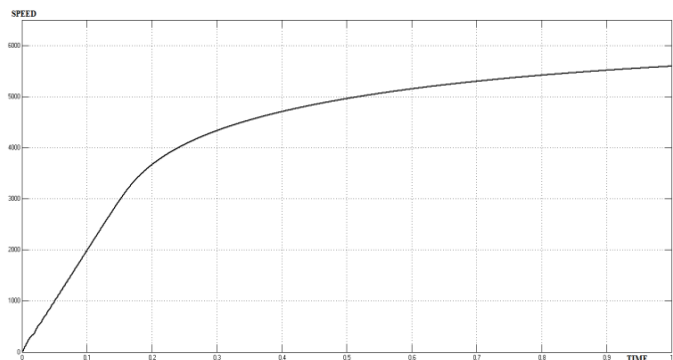

Fig 13: Speed Characteristics of SRM

## VI. CONCLUSION

A single controllable switch converter required only a one controllable switch and a diode that overcomes the drawbacks of the conventional converter. The minimum number of passive and active devices of single switch drive is retain its characteristics. The single switch converter drive is compact and low cost as compare to other. It is believed, as of date, that this is the most viable low cost brushless variable speed drive system many applications. The Switched Reluctance Motor, Single switch Converter and Asymmetric bridge converter, MATLAB model and its Simulation of the drive system are presented. The new drive system is superior to conventional drive in number of active devices used, their ratings, packaging size and inferred cost.

## REFERENCES

[1] “Switched Reluctance Motor Drives” Modeling, Simulation, Analysis, Design, and Applications By R. Krishnan. Fellow, IEEE. © 2001 by CRC Press LLC.

[2] Jaehyuck Kim, R. Krishnan “Single-Controllable-Switch-Based Switched Reluctance Motor Drive for Low-Cost Variable- Speed Applications” IEEE transaction 978-1-4244-2893-9/09, 2009, pp 2535-2542.

[3] Nisha Prasad and Dr. Shailendra Jain “Simulation of Switched Reluctance Motor for Performance Analysis Using MATLAB/SIMULINK Environment and use of FPGA for its control” IJEECE, April 2012, pp. 91-98.

[4] Vikas S. Wadnerkar, Dr. G. Tulasi Ram Das, Dr. A.D.Rajkumar, “Performance Analysis Of Switched Reluctance Motor; Design, Modeling And Simulation Of 8/6 Switched Reluctance Motor” JATIT, 2008, PP. 1118-1124.

[5] ] Jin-Woo Ahn, Jianing Liang and Dong-Hee Lee “Classification and Analysis of Switched Reluctance Converters”. JEET, Vol.5, No. 4, pp 571-579, 2010

[6] “A first course on electrical drive” by S. K. Pillai