

Emerging Technologies in Communication

Shradha Bhingardive¹, Mrs. N. V. Dhole²

¹ P.G Student, Department of Electronics and Telecommunication Engineering, RMDSSOE Pune, Maharashtra, India

shradhabhingardive2@gmail.com

² Assistant Professor, Department of Electronics and Telecommunication Engineering, RMDSSOE Pune, Maharashtra, India

nandini.dhole@sihngad.edu

Abstract – Conventional wireless communication schemes use radio/micro wave frequencies for data transmission, primarily because of the availability of high sensitivity receivers and ability to provide broad coverage at low frequencies and line of sight communication at high frequencies. But, RF can support only a limited bandwidth due to confined spectrum availability. Therefore the expanding demand for wireless data has led to clogging of the radio spectrum. Thus there is a need to study and use new communication technologies in near future that will reduce interference and will be a clean source of communication. Communication is providing new advances constantly, people are depending more and more on the benefits they provide.

Key Words: Visible Light Communication, Loon Project, Near Field Communication, White Fi, IEEE 802.15.7

1. INTRODUCTION

The act of conveying intended meaning from one entity to another entity through the use of mutually understood signs and rules is called as communication. Wireless communication is the transfer of information between two or more points that are not connected by an electrical conductor. Services are provided by wireless operations permit such as long range communications that are difficult or not possible to implement with the use of wires. The most common wireless technologies use radio. Radio wave communication need short distances may be such as a few meters for television and thousands kilo meters for deep-space radio communications. UN agency predicts the global demand for mobile telephones remains strong and will continue despite the economic crisis. The number of mobile cellular subscriptions had already reached 4.6 billion and above.

Wireless network technologies have very low power usage. Few equipment's can operate on low power or can also get required power for operation from environment. Thus sensors can be deployed into environment where continuous power supply is not possible.

Radio waves are produced by combination of electric and magnetic fields at right angles. Spectrum of these waves is called the electromagnetic spectrum and also occurs at different frequencies. More than 150 countries of the world have frequency management organizations. These frequency management organizations meet every three or four years at the World Radio communications Conference (WRC), sponsored by the International Telecommunications Union (ITU). Spectrum issues are discussed by them, argue the merits of different spectrum proposals, and resolve spectrum conflicts.

Wireless data transmission is constantly increasing, thus the radio frequency spectrum is becoming increasingly crowded. Spectrum is becoming more crowded and spectral management is becoming an issue of concern. Mobile data will grow rapidly between 2013 and 2018 and the growth is strongest. Data usage, is rapidly increasing thus, there is a major concern for mobile operators to focus on public alternative technologies. Wireless broadband data access is increasing rapidly with increase in mobile traffic followed by the smartphone, laptop and tablet popularity.

2. TECHNOLOGIES

Emerging Wireless Technologies:

- Visible Light Communication (Li Fi)
- Loon Project
- NFC SIM Card
- White Fi

2.1 Visible Light Communication (VLC):

Dr. Harald Haas from University of Edinburgh, UK, suggested a new technology called as Li Fi that overcomes the shortcomings of Wi-Fi. In this technology radio waves are replaced with visible light as the carrier. Li-Fi or also called as optical Wi-Fi is cheaper and safer than the Wi-Fi, because it don't need any access control systems and passwords. Light pulses cannot penetrate through walls, thus provide good security. The electric light does not interfere with light

communication. The light sources can provide internet access at very high speed. Figure 1 shows VLC architecture. Li-Fi technology transmits data wirelessly with the use of led. LED lighting conserves energy, contains no mercury and provides extra brightness with long life compared to traditional lighting. Data is transmitted via light by changing the flicker rate with different combinations of 1 and 0, and its intensity is modulated that it is impossible to notice by human eyes. [1], [2]

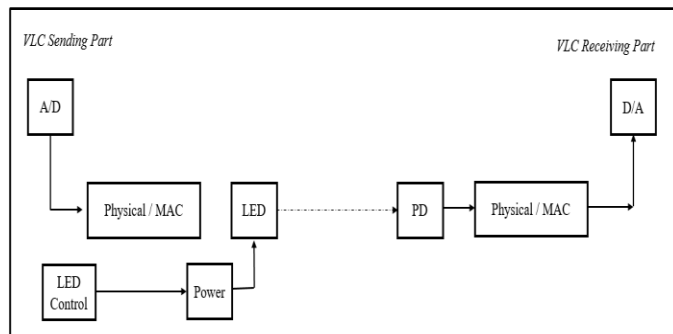

Fig -1: VLC Architecture

IEEE 802.15.7 is a standard introduced to provide the visible light communication system, for connecting devices via visible light spectrum. IEEE 802.15.7 compliant networks consist of two types of nodes, namely, a coordinator and a remote device. The standard defines three types of topologies, peer-to-peer topology, star topology and broadcast topology. The IEEE 802.15.7 has two layers of ISO/OSI stack protocol- Physical and Medium Access Control (MAC) layers. [3]

2.2. Loon Project

A new project, the project Loon is proposed by Google that can provide internet access to remote and rural areas. It was launched in 2013. The Loon network, balloons travel around the Earth and bring access points to the users who cannot connect directly to the global wired Internet. Deployment of base stations for every location on the Earth seems to be impossible. It is a concept of providing Internet from the sky. Balloon network is formed in the sky that will transmit signals to nearest base stations and ISPs on earth. One balloon can provide connectivity to a ground area about 70 to 80 km in diameter using a wireless communications technology.



Fig -2: Google project Loon

The project uses high altitude platform or balloons placed in the stratosphere at an altitude of about 20 to 32 km which is safe from bad weather and flights to support an aerial wireless network. The balloons are super pressure balloons filled with helium. Project Loon began in June 2013 with an experimental pilot in New Zealand, where pioneers of Project Loon tested this technology. Thirty balloons were launched to a small group of pilot testers. The results of the pilot test, tests in New Zealand, California's Central Valley and in North East Brazil are used to improve the technology and for preparing the next stages of the project. A balloon can last around 100 days in stratosphere that are made from sheets of polyethylene plastic and measure 15 meters wide by 12 meters tall when fully inflated. When a balloon has to be taken out of service, gas is released from the balloon, to bring the balloon down to earth in a controlled descent. [4], [5], [6]

2.3. NFC SIM Card

Near Field Communication (NFC) is contactless form of data transfer that provide a connection between two devices over a short distance. Use of NFC is conceivable in a large number of sectors and application areas. Depending on an application's requirements, technical implementation of NFC is simple, quick and inexpensive. NFC provide data exchange over distances of up to 10 centimetres in active or passive modes, over a short range using a very high frequency and with enhanced security mechanisms, it thus permits not only information about products to be read out, but also standardised, secure data exchange between electronic devices for everyday use.

Apple Pay and Samsung Pay (IOS 8 and Android 4.4 onwards) are a natural evolution of the NFC payment system in general that provide convenient mobile transactions without the need of any wireless data network. The multifunctional car key has been developed at the BMW Group which will allow BMW drivers to just open doors or start the engine. Driver can have information about the car, whether it is locked, amount of fuel left or the precise location of the vehicle on a mobile terminal with an NFC interface by just holding the key near the device.



Fig -3: Components of an NFC ecosystem

NFC enabled SIM cards are to become a worldwide standard. The GSM Association has announced that a consortium has been formed and has committed to support and implement SIM cards, embedded with NFC. Both SIM and SD cards can be equipped with NFC chips and some companies are preparing to offer these options so large number of customers can start using NFC technology. For example, merely touching a film poster equipped with an NFC chip with an NFC capable device enables a trailer to be displayed and tickets to be reserved at the nearest cinema, shelves in the supermarket which are equipped with NFC provide information about the origin and treatment of fruit and vegetables, can indicate whether the engine oil is suitable for car. [7], [8]

2.4. White Fi

White-Fi or Super Wi-Fi, is approved in February 2014. TV white spaces are the unused TV channels can be used to deliver broadband services. TV white spaces devices and networks will work similar like conventional Wi-Fi, but the advantage is that the TV signals travel over longer distances and penetrate walls and other obstacles, require fewer access points to cover the area. TV White Spaces (TVWS) are frequencies made available for unlicensed use. This spectrum is located in the 54-216 MHz and 470-698 MHz, VHF and UHF bands respectively. In order to utilize this unlicensed spectrum band, White Space Devices (WSD) must communicate with a database that provide a list of currently available white space channels and ensure required users are protected. The available channels may vary, depending on WSD device type and location. It uses a new technique called dynamic spectrum sharing. [9]

The FCC Second Memorandum Opinion and Order established the TV white space rules. Various unlicensed devices, called White Space Devices (WSDs), can make use of a particular TV channels in the VHF or UHF bands. The Commission allows fixed and personal/portable unlicensed devices that will operate in the TV bands. The Commission allows fixed devices to operate on any channel between 2 and 51, excluding channels 3, 4 and 37 and also personal portable devices to operate on channel between 21 and 51,

except channel 37.

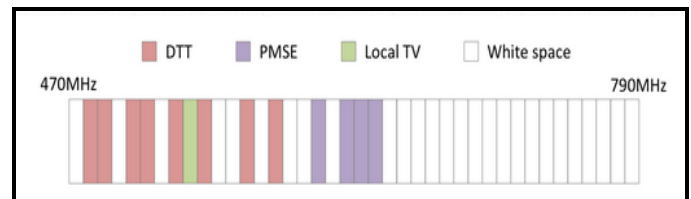

Fig -4: White spaces in a specific location

3. CONCLUSIONS

The advancement of technology has an enormous impact on the world. Communication technology has rapidly changed the way society operates. New advances in communication are being developed constantly and rapidly, people are depending on them. Communication technology has become important in education, business, politics, crisis responses, etc. New technology should be developed increase data rates, network capacity, reduce power consumption, create cheaper devices and enable global roaming. New technology could fundamentally change future wireless communications.

REFERENCES

- [1] Hyun-Seung Kim, Deok-Rae Kim, Se-Hoon Yang, Yong-Hwan Son, and Sang-Kook Han, "An Indoor Visible Light Communication Positioning System Using a RF Carrier Allocation Technique", *Journal Of Lightwave Technology*, vol. 31, No. 1, January 1, 2013, pp.134-144.
- [2] Iskandar Slaiman, Nor Hisham B. Hamid, Tang Tong Boon, Electrical and Electronics Engineering department, University Technology Petronas Tronoh, Malaysia, "Optical Wireless Communications Through Visible Light LEDs: An Overview", *International Journal of Engineering Research & Technology (IJERT)*, Vol. 3 Issue 3, March – 2014, pp. 1152-1156.
- [3] A. Musa, M. D. Baba, and M. A. Mansor, "Analysis of the Contention Access Period (CAP) Model for the IEEE 802.15.7 Visible Light Communication", *International Journal of Computer and Communication Engineering*, Vol. 2, No. 5, September 2013, pp. 621-624.
- [4] Chang-Jun Ahn, "An applicable 5.8 GHz wireless power transmission system with rough beamforming to Project Loon", *Science Direct*, Elsevier, 19 February 2016.
- [5] Chang-Jun Ahn, "Wireless Power Transmission with Rough Beamforming Method", 2015 2nd National Foundation for Science and Technology Development Conference on Information and Computer Science, pp. 305-309.
- [6] Dinh Thai Hoang, Dusit Niyato and Nguyen Tai Hung, "Optimal Energy Allocation Policy for Wireless Networks in the Sky", *IEEE ICC 2015 - Mobile and Wireless Networking Symposium*, pp. 3204-3209.
- [7] Debajyoti Pala, Vajirasak Vanijjab, Borworn Papisatornc, "An Empirical Analysis towards the Adoption of NFC Mobile Payment System by the End User", *The 7th International Conference on Advances in Information Technology*, pp. 13-25.
- [8] Benjamin Burghardt, Dr. Marcus Gemeinder, Markus Huber, Dr. Jorg PreiBinger, Peter Preuss, Tobias Schölleremann, David Schulz, Dr. Rainer Steffen, Kerstin Taumer, "Near Field Communication, Organising everyday life intuitively", 2010.
- [9] Onur Altintas, Koichi Seki, Haris Kremos, Makiko Matsumoto, Ryokichi Onishi and Hideaki Tanaka, "Vehicles as Information Hubs during disasters: Glueing Wi Fi to TV White Space to Cellular Networks", *IEEE Intelligent Transportation Systems Magazine*, Spring 2014, pp 68-71.