

# Impedance Source Converter for PV Application and Stand Alone System

Ishwar Singh Chandra<sup>1</sup>, Tikeswar Gajpal

*ishwar.chandra67@gmail.com*<sup>1</sup>

<sup>1</sup>Masters Scholar, Department of Electronics & Telecommunication, RITEE, Raipur

<sup>2</sup>Assistant professor, Department of Electronics & Telecommunication, RITEE, Raipur

\*\*\*

**Abstract** -Renewable energy sources are becoming very popular for the standalone system as single phase or three phase domestic supply, charging station for electric vehicle, agent based control of wind energy system and battery charging for different localized application. In many applications one need to develop such a system in the control and system transient that the function of the conversion of renewable energy in the usable form must be more efficient for the utility. Since the present scenario of renewable energy comprise of cost effective solar panel as commercial with the various subsidy available. However, problem associated with the system level is conversion of power and the transmission to the consumer end. In this work presents a modelling of impedance source converter for the PV application.

**Key Words:** Impedance Source Converter, DC-DC Converter, PV System, Lattice Network, Standalone System.

## 1. INTRODUCTION

Renewable energy is future as alternative to the conventional power system with the different voltage and power level. The newly proposed Z-source inverter has proven in the literature to exhibit steady state voltage for desired level. This paper presents the brief introduction on the modelling of the impedance source converter. Impedance source converter is given by the [1] for the fixed network within the system for the generation of pulse during the shoot through state also. In [2] and [3] definite application is given for the converter with the grid connected system and stand alone system. As the energy from the sun is free, the major cost of photovoltaic generation is the installation cost, which is mainly composed of the costs of solar modules and the interface converter system, also called the power conditioning system (PCS). With the development of solar cell technology, the price of solar modules has dropped dramatically. A recent worldwide survey shows that in the last three years, the retail price of solar modules has dropped 16.95%. [3]

The basic impedance-source network can be generalized as a two-port network with a combination of two basic linear energy storage elements, i.e., L and C (dissipative components (R) are generally omitted). However, different configurations of the network are possible to improve the performance of the circuit by adding different nonlinear elements into the impedance network, e.g., diodes, switches, and/or a combination of both.

There are several disadvantages of the Current Source Inverter and Voltage Source Inverter, and the impedance source converter is based to overcome such disadvantages. In VSI output voltage cannot go beyond the input voltage as it is buck type converter while the CSI the output voltage cannot be less than the input voltage.

Various literatures have been proposed in past few years in [4]-[17]. Some of the paper proposed method to generate voltage by the standalone system using PV and battery system which is most common approach also known as traditional system.

In [5] a hysteresis control method is given for the dynamic regulation along with the PV and battery connected z source converter. However, hysteresis control requires the actual datasheet of system as current range is fixed, and is not feasible for the variable load circuit.

In this work impedance source converter is discussed with the open loop control and without battery storage system. The organization of thesis is divided in to various category Very first section gives brief introduction on the work we are performing. In second section Photovoltaic conversion with I-V characteristic is discussed. In third section Impedance source converter with basic structure and lattice is discussed. Whereas, Simulation result and Conclusion is discussed in later section.

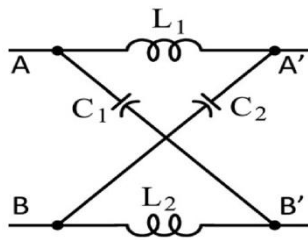

Fig. 1 Basic lattice Network

1.2 Photo Voltaic System.

Photovoltaic system is very popular and less efficient as only 40% efficiency is there to utilize the 100% irradiance on the panel. However, multistage conversion of power from one source to another reduces the overall efficiency of the system. To improve conversion efficiency in such cases the overall stages are reduced using the impedance source conversion.

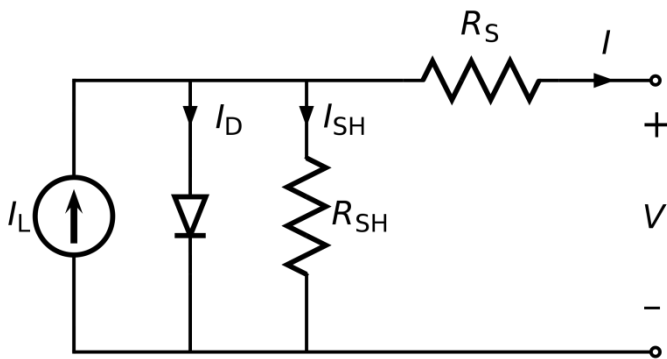

Fig. 2 Basic Cell Arrangement of the solar panel

In figure 2 basic cell structure of the solar panel is given which is more near to simulate a solar panel with the constant current source and differential voltage gain.

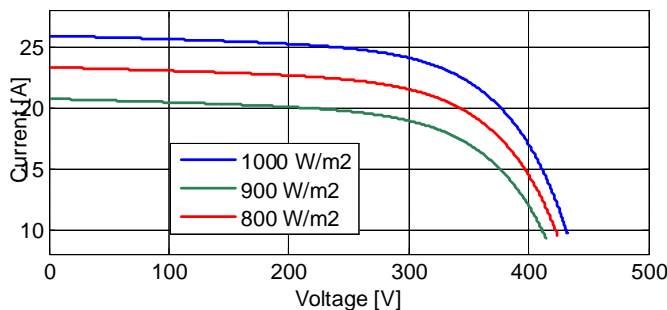

Fig. 3 I-V Characteristic of the PV for different Irradiance Level

The I-V characteristic of a standard photovoltaic is given in figure 2, which is calibrated for different irradiance level.

Since the equations are given for the current as function of temperature as long as temperature changes the current may also change. Due to the fact that the change must not fluctuates the condition of the output load at inverter or dc link end.

$$I = I_{ph} - I_0 \left\{ \exp \left( \frac{q(V + IR_s)}{NKT} \right) - 1 \right\} - \frac{(V + IR_s)}{R_{sh}} \tag{1}$$

$$I_{ph} = \frac{\beta}{1000} \times \{ I_{sc} - K_i (T - 298) \} \tag{2}$$

$$I_0(T) = I_0 \left[ \frac{T^3}{T_{nom}^3} \right] \exp \left\{ \left( \frac{T}{T_{nom}} - 1 \right) \cdot \frac{E_g}{NV_t} \right\} \tag{3}$$

To avoid this fluctuation at the load end conventional system have inbuilt conditioner unit and the photovoltaic MPPT duty cycle conditioner. Above equations, one can estimate the behavior of the solar panel for the specific irradiance.

- I = Current to the load
- I<sub>ph</sub> = Photo current
- I<sub>0</sub> = Reverse saturation current of the diode
- q = Electron charge
- V = Voltage across the diode
- K = Boltzmann constant
- T = Junction Temperature
- N = Ideality factor of the diode
- R<sub>s</sub> = Series resistors
- R<sub>sh</sub> = Shunt resistor
- I<sub>sc</sub> = Short circuit current of the cell
- K<sub>i</sub> = Temperature co-efficient
- β = Solar radiation

1.2 Impedance Source Converter

Impedance source converter is formation and connection of impedance source network with power source and single phase or three phase connection of inverter. In many case for close loop operation the impedance source voltage is measured across the C<sub>1</sub> and C<sub>2</sub>.

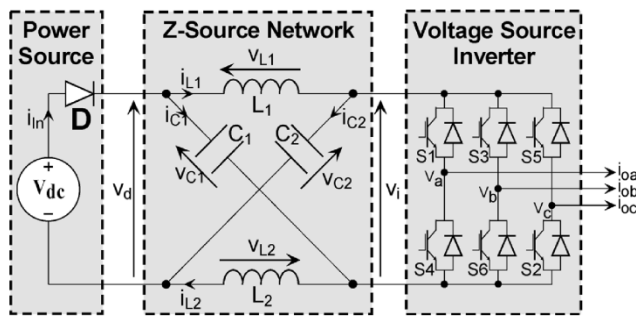

Fig. 4 Basic Schematic of System with Detailed Connection

In above network shown in figure 3 basic schematic connection impedance source converter for the continuous operation of the system. Impedance source converter is presented with the general case three phase conversion with boost circuit as inbuilt of the power source in the DC voltage.

Also the modes can be divided in to two categories viz shoot through mode or non shoot through mode. In shoot through mode the output inverter is short circuited and diode get reversed biased and voltage across inductor is same as that of capacitor voltage. Given by equation (4)

$$\left. \begin{aligned} V_{C1} + V_{C2} &> V_{in} \\ V_{L1} = V_{C1}; V_{L2} &= V_{C2} \end{aligned} \right\} \quad (4)$$

In this case there is exchange of energy between the capacitor and inductor. Whereas, in second mode i.e. non-shoot through state the inductor voltage is same as that of difference of output voltage to the capacitor voltage.

$$\left. \begin{aligned} V_{L1} &= V_0 - V_{C1} \\ V_{L2} &= V_0 - V_{C2} \end{aligned} \right\} \quad (5)$$

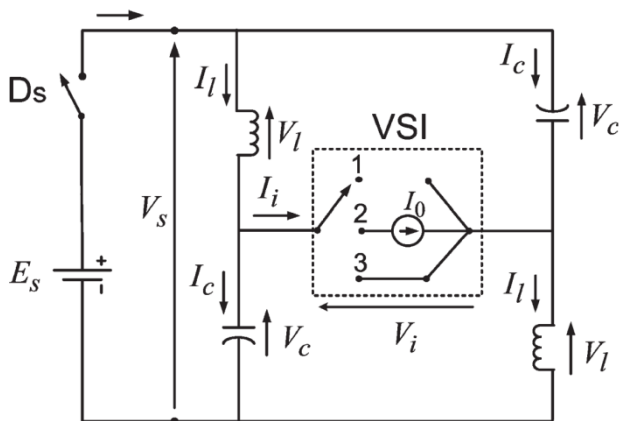

Fig. 5 Different States of the Impedance Network for the Voltage Source Converter

In this converter there are three states of operation namely,

- i. Open Circuit Operation
- ii. Short Circuit Operation
- iii. Normal State.

In all three stages the variation is considered for the voltage source converter is connected in cascaded with the impedance network. However, one can observe the states of operation by means of the conventional inverter unit.

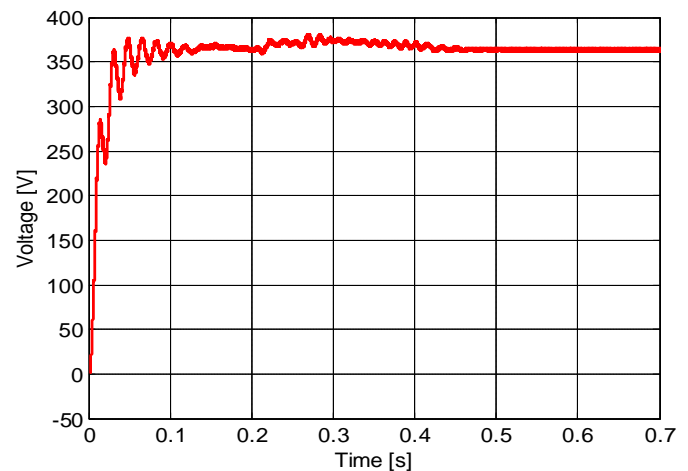
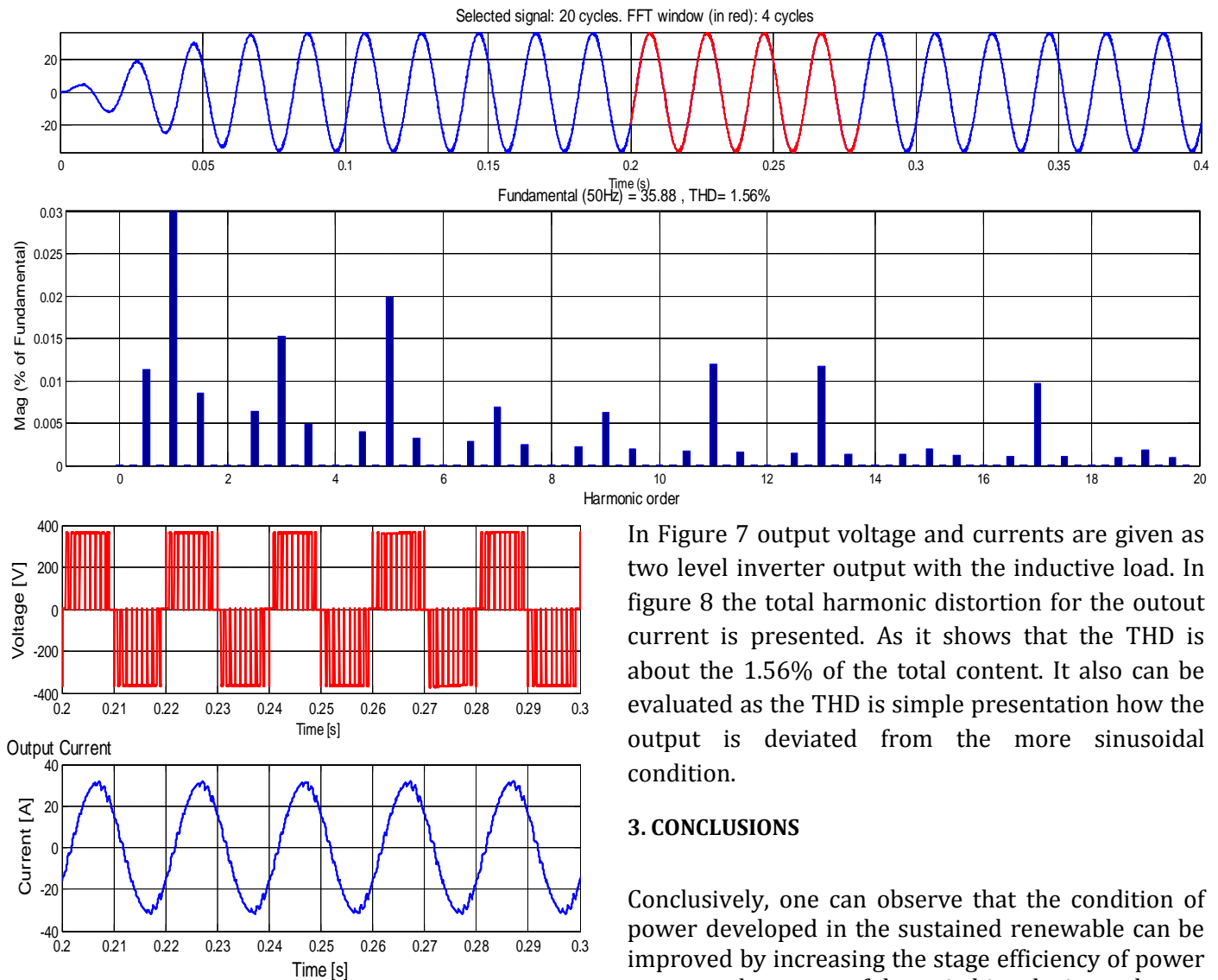

Fig. 6 Output Voltage of the Impedance Source Converter at the DC Link

In Figure 6 it is very much clear that the MPPT transient on the output voltage as that of the input from the supply as PV.



**Fig. 7 Output Voltage and Current of the Inverter.**

The output voltage considered at the dc link location is fed to the inverter unit for conversion into single phase supply. To achieve this conversion one needs to develop the modular PWM generation for a unity modulation and the 1000Hz switching

operation. However, in the fundamental consideration the sine wave is compared with the triangular wave to generate PWM pulse and required fundamental frequency. Here, in this work 50Hz is taken as the fundamental frequency for the load current of 36[A].

In Figure 7 output voltage and currents are given as two level inverter output with the inductive load. In figure 8 the total harmonic distortion for the output current is presented. As it shows that the THD is about 1.56% of the total content. It also can be evaluated as the THD is a simple presentation of how the output is deviated from the more sinusoidal condition.

### 3. CONCLUSIONS

Conclusively, one can observe that the condition of power developed in the sustained renewable can be improved by increasing the stage efficiency of power converter by means of the switching device and state. In this work study of PV and Impedance Source converter is presented and validated successfully in MATLAB/SIMULINK® environment. Also, the inverter circuit with the two levels out in reduced THD is presented in the work. Current THD is almost 1.56% which can be accepted by the virtue of application in different circuitry.

**Fig. 8 THD response of Current at the Inverter Output Voltage.**

### ACKNOWLEDGEMENT

This work is presented as a supportive document under the master thesis of author I. S. Chandra under the guidance of Mr. T. Gajpal, at Raipur Institute of Technology, Raipur

**REFERENCES**

- [1] Peng, Fang Zheng. "Z-source inverter." *Industry Applications, IEEE Transactions on* 39.2 (2003): 504-510.
- [2] Peng, Fang Zheng, Miaosen Shen, and Zhaoming Qian. "Maximum boost control of the Z-source inverter." *IEEE Transactions on power electronics* 20.4 (2005): 833-838.
- [3] Huang, Yi, et al. "Z-source inverter for residential photovoltaic systems." *IEEE Trans. Power Electron* 21.6 (2006): 1776-1782.
- [4] Badin R, Huang Y, Peng FZ, Kim HG. Grid interconnected Z-source PV system. In: *Proceedings of IEEE power electronics specialists conference, Orlando, USA; 2007. p. 2328-33.*
- [5] Jinjun Huang, Jianyong Zheng, Jun You, et al. Z-source three-phase gridconnected PV system based on current hysteresis control. *Electr Power Autom Equip* 2010;30(10):94-7.
- [6] Li Y, Anderson J, Peng FZ, Liu DC. Quasi-Z-source inverter for photovoltaic power generation systems. In: *Proceedings of the twenty-fourth annual IEEE applied power electronics conference and exposition, Washington (DC, USA); 2009. p. 918-24.*
- [7] Bradaschia F, Cavalcanti MC, Ferraz PEP, Neves FAS, dos Santos EC, da Silva JHGM. Modulation for three-phase transformerless Z-source inverter to reduce leakage currents in photovoltaic systems. *IEEE Trans Indust Electron* 2011;58(12):5385-95.
- [8] Vinnikov D, Roasto I. Quasi-Z-source-based isolated DC/DC converters for distributed power generation. *IEEE Trans Indust Electron* 2011;58(1):192-201.
- [9] Anderson J, Peng FZ. Four quasi-Z-source inverters. In: *Proceedings of IEEE power electronics specialists conference, Rhodes, Greece; 2008. p. 2743-9.*
- [10] Park JH, Kim HG, Nho EC, Chun TW, Choi J. Grid-connected PV system using a quasi-Z-source Inverter. In: *Proceedings of the twenty-fourth annual IEEE applied power electronics conference and exposition, Washington (DC, USA); 2009. p. 925-9.*
- [11] Li Y, Peng FZ, Cintron-Rivera JG, Jiang S. Controller design for quasi-Z-source inverter in photovoltaic systems. In: *Proceeding of energy conversion congress and exposition, Atlanta, USA; 2010. p. 3187-94.*
- [12] Bo D, Li YD, Zheng ZD. Energy management of hybrid DC and AC bus linked microgrid. In: *Proceedings of power electronics for distributed generation systems, Hefei, China; 2009. p. 713-6.*
- [13] Tina GM, Pappalardo F. Grid-connected photovoltaic system with battery storage system into market perspective. In: *Proceedings of sustainable alternative energy, Valencia, Spain; 2009. p. 1-7.*
- [14] Wang WL, Ge BM, Bi DQ, Sun DS. Gridconnected wind farm power control using VRB-based energy storage system. In: *Proceeding of energy conversion congress and exposition, Atlanta, USA; 2010. p. 3772-7.*
- [15] Jayasinghe SDG, Vilathgamuwa DM, Madawala UK. A battery energy storage interface for wind power systems with the use of grid side inverter. In: *Proceeding of energy conversion congress and exposition, Atlanta, USA; 2010. p. 3786-91.*
- [16] Ge Baoming, Wang Wenliang, Bi Daqiang, Rogers Craig B, et al. Energy storage system-based power control for grid-connected wind power farm. *Int J Electr Power Energy Syst* 2013;44(1):115-22.
- [17] Sebastian R. Modelling and simulation of a high penetration wind diesel system with battery energy storage. *Int J Electr Power Energy Syst* 2011;33(3):747-67.