

## Design and Development of Telescopic Conveyor

Prof. M. M. Kulkarni<sup>1</sup>, Miss Gayatri N. Chavan<sup>2</sup>, Mr. Shubham A. More<sup>3</sup>, Mr. Anil S. Mechkar<sup>4</sup>,  
Miss Vishakha A. Hinge<sup>5</sup>

<sup>1</sup>Professor, Dept. Of Mechanical Engineering, Smt Kashibai Navale College of Engineering, Pune, Maharashtra, India.

<sup>2</sup>Graduate, Dept. Of Mechanical Engineering, Smt Kashibai Navale College of Engineering, Pune, Maharashtra, India.

<sup>3</sup> Graduate, Dept. Of Mechanical Engineering, Smt Kashibai Navale College of Engineering, Pune, Maharashtra, India.

<sup>4</sup> Graduate, Dept. Of Mechanical Engineering, Smt Kashibai Navale College Of Engineering, Pune, Maharashtra, India.

<sup>5</sup> Graduate, Dept. Of Mechanical Engineering, Smt Kashibai Navale College Of Engineering, Pune, Maharashtra, India.

\*\*\*

### Abstract

Industries are looking for machines which will save manpower, space, money and time for production. In many material handling equipments, belt conveyors are popular and used in many industries. This paper overcomes the drawbacks of traditional belt conveyors and introduces a new system with the help of a project on Design and Development of Telescopic conveyor. Our current attempt is towards fabricating an economical telescopic material unloader by adopting the exiting simple design procedure.

It is a pneumatic & belt drive movable equipment for unloading heavy materials like boxes, High weight Bundles and Bags loading and & unloading purpose it is used, it will lift up to 0.1 meter height with the help of pneumatic cylinders & it will move to and fro direction up to 1.5 meter with the help of belt drive this is working with the help of Geared motors. The capacity of this equipment is up to 300 kg as per our design it will vary. By using this equipment material unloading and loading capacity is 250 to 300 kg/hr. The name of this equipment is Telescopic Truck Unloader. Easy to shift it from one place to another place with the help of trolley wheels with in plant and transportation is also easy for one location to other.

It is found that design and development of telescopic conveyor system works satisfactory to meet design point of view. It is reliable, compact, adjustable, saves working man-hours and increasing profitability of industries engaged in material handling.

### 1. INTRODUCTION

This A telescopic belt conveyor is an effective and ergonomic alternative to labour-intensive routines. Operators can move heavy or awkward packages into or out of a container/truck rapidly with little effort. Extending some 20 meters/65 ft., telescopic belt conveyors can be used to load/unload any type of loose-loaded cargo - typically parcels, boxes, sacks & tyres. An intuitive smart-pad on either side enables precise control of the boom's elevation and telescopic movement. Push buttons at the operator end of the boom control activation, lights, belt direction etc.

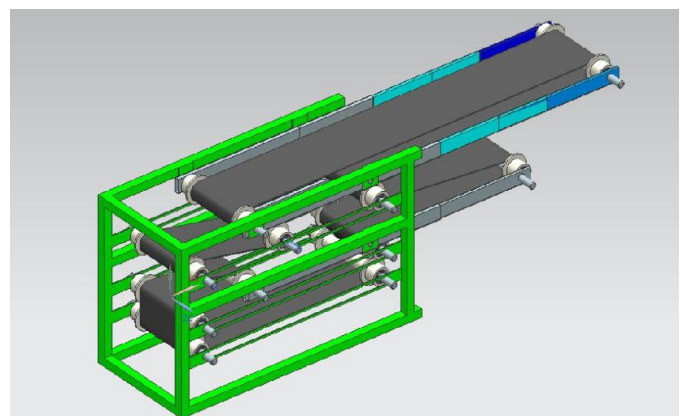

Fig. telescopic conveyor

A telescopic belt conveyor is an effective and ergonomic alternative to labour-intensive routines. Operators can move heavy or awkward packages into or out of a container/truck rapidly with little effort. Extending some 20 meters/65 ft., telescopic belt conveyors can be used to load/unload any type of loose-loaded cargo - typically

parcels, boxes, sacks & tyres. An intuitive smart-pad on either side enables precise control of the boom's elevation and telescopic movement. Push buttons at the operator end of the boom control activation, lights, belt direction etc. Exceptionally small base sections combined with up to five extending sections enables us to provide *custom* telescopic conveyors to suit your requirements.

### 1.1 Literature Review

**Nalam Surya Sandeep** studied about, Reducing Manpower cost in industries, Space, Money and Time saving purpose every one preferring simple equipment for loading and unloading materials. For the past decade, material handling organizations has been introduced and applied as an option for different types of Unloaders. It is a simple yet effective means reliable and cost effective manner. Their present work deals with utilization of telescopic material unloader for reduce the Manpower cost, time saving and safe loading and unloading the materials in industries. Our current attempt is towards fabricating an economical telescopic material unloader by adopting the exiting simple design procedure.

They concluded by using 2.2kw low capacity motor we designed and implemented 15ton/hr capacity Telescopic Material Unloader. The efficiency of Telescopic Material Unloader is higher than the Loader efficiency by design parameters. The average unloading capacity of this equipment is 18.5tonn/hr in the interval of 24hrs. [1]

**R. K. Bhoyar** studied about Belt conveyor is the transportation of material from one location to another. Belt Conveyor has high load carrying capacity, large length of conveying path, simple design, easy maintenance and high reliability of operation. In this paper the study is on adjustable height of belt conveyor for variable speed moving in different direction of a belt conveyor system. It transfers material in two different destinations from a single source. For that it is required to design all the components of belt conveyor like belt width, belt speed, pulley diameter, chute to transfer the material, etc. This paper attempts to discuss the generalized design consideration for adjustable radial belt conveyor. [2]

## 2. Result and Discussion

This paper deals with study of telescopic conveyor and results are plotted by experimenting on the set up. This set up has been manufactured by us and then various experiments have been conducted and results are found as follows.

### 2.1 Load vs. Velocity

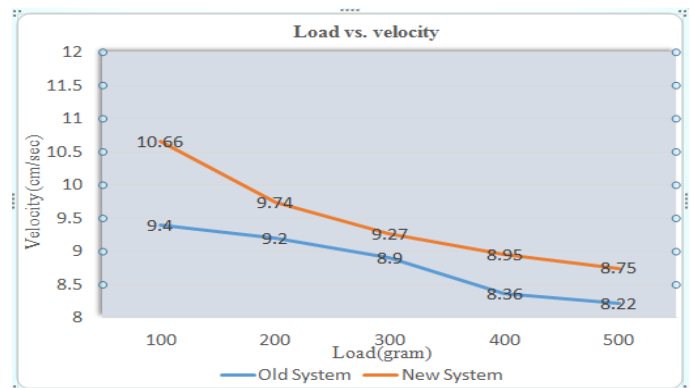

Above graph shows the comparison of velocities between conventional conveyor system and telescopic conveyor system. At no load condition the velocity of conventional conveyor system is 0.1014 m/sec and of telescopic conveyor system is 0.1198 m/sec. different readings were taken for different loading condition from which it is observed that velocity of conventional conveyor system is less than telescopic conveyor system hence telescopic conveyor system is more suitable than conventional conveyor system for loading and unloading of materials.

### 2.2 Load vs. Time

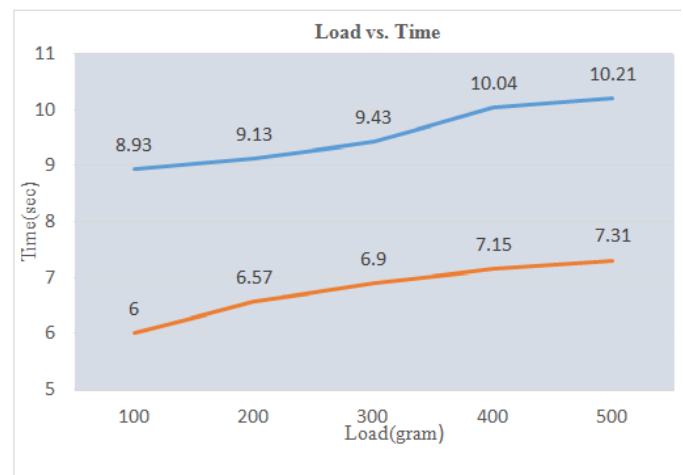

Above graph shows the comparison of speeds between conventional conveyor system and telescopic conveyor system. At no load condition the speed of conventional conveyor system is 8.28 rps and of telescopic conveyor system is 5.34 rps. Different readings were taken for different loading condition from which it is observed that speed of conventional conveyor system is greater than telescopic conveyor system hence telescopic conveyor system is more suitable than conventional conveyor system for loading and unloading of materials.

### 2.3 Distance to be travel vs. Space Required

### REFERENCES

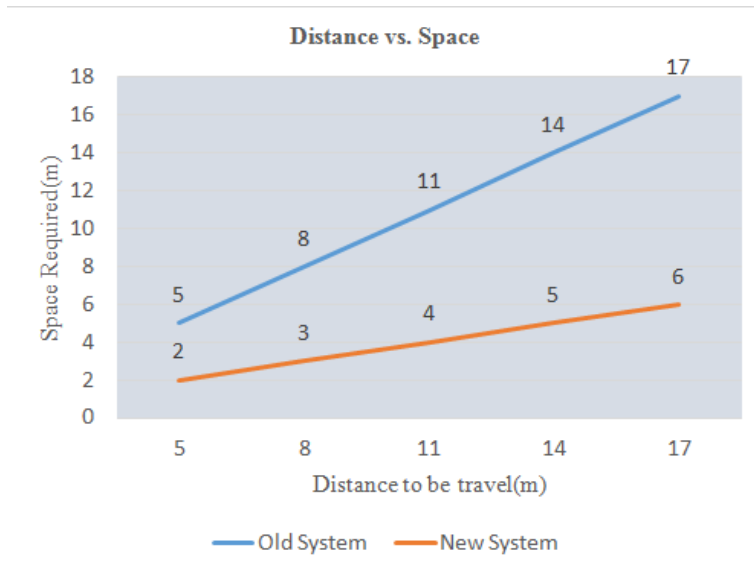

- [1] Nalam surya Sandeep, Amar Nageshwar Rao “Design and detail of telescopic material unloader”, International journal of innovative research in science, engineering and technology.
- [2] R K Bhoyar,,C C Handa “Design consideration for radial adjustable belt conveyor system” International journal of mechanical engineering and robotics research.

Above graph shows the comparison of space required for conventional conveyor system and telescopic conveyor system. Suppose the material is to be carry at 10 m distance the length of the conveyor required is also 10 m in case of conventional conveyor system but for telescopic conveyor system after completion of work we can put the conveyor in retracted position whose length might be 3 m means telescopic conveyor system saves 7 m space in the plant that’s why telescopic conveyor system is more suitable than conventional conveyor system for loading and unloading of materials.

### 3. CONCLUSIONS

We have design a Telescopic belt conveyor, and we concluded that -

1. Velocity of telescopic conveyor system is 13% greater than conventional conveyor system.
2. Operation Time required for transfer the material in telescopic conveyor system is 33% less than conventional conveyor system.
3. Space required for storage of telescopic conveyor system is 62% less than conventional conveyor system hence system is very compact.