

DESIGN AND DEVELOP PORTABLE FLEXURAL TEST FIXTURE FOR 2-POINT AND 3-POINT LOADING.

Mrs.J.P.Wagh*1, Akshay R. Swami*2, Anant Y. Shitap*3, Achyut A. Lohar*4, Tushar D. Pondkule*5

*1Prof. Dept. of Mechanical Engineering, Pimpri Chinchwad College of Engineering Pune, Maharashtra, India

*2 *3 *4 *5 student Dept. of Mechanical Engineering, Pimpri Chinchwad College of Engineering Pune, Maharashtra, India

ABSTRACT:

Present industrial scenario needs economical, less time consuming, multipurpose and compact testing equipments that can reduce the cost and save time. In this project, a 2-point and 3-point flexural test accessories are designed and developed which are portable and can be used with UTM or in any conditions where loading is available, which makes this fixture portable. At present there is no such machine which can perform both 2-point and 3-point flexural testing. So, we did research on this topic to get more knowledge about present status of flexural testing machine and method of conducting test. On that basis we have designed the fixture which can take load upto 20 kN. Initially we considered the cast iron rectangular block as a base for the fixture, but it was very heavy as well as uneconomical. So, we preferred I-beam as a base instead of rectangular block, as I-beam is strong in bending as far as construction and loading is concerned. Thus we designed the fixture by considering safety and economical aspect.

1. INTRODUCTION

The bending test (flexural testing) is commonly performed to measure the flexural strength and modulus of Elasticity (E) for different types of materials and products. This test is performed on Universal Testing machine (tensile testing

machine or tensile tester) with a 2 point or 3 point flexural fixture. The most common method for product testing is 3 point test.

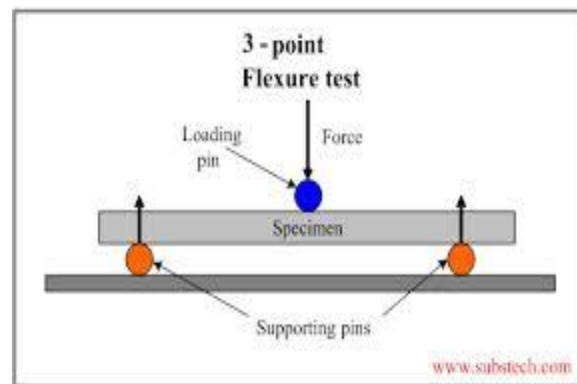

Figure 1.Flexural Bending Test

2. CONSTRUCTION:

1. It consist of I-beam, roller supports, Jig and C-channel.
2. I-beam is mounted on UTM base to perform test.
3. For 3-point flexural testing, two roller supports are mounted on I-beam. On these roller supports the specimen or test component is mounted which acts as a simply supported beam.
4. While performing 2-point flexural test two roller supports are replaced by one attachment which is mounted on one side of the I-beam. The specimen is

clamped to this attachment which makes the setup to act as a cantilever beam.

5. When loading condition is available other than Universal Testing Machine then mount I-beam on c-channel to conduct test as shown in fig.9

6. The jig is mounted on the movable cross head of the UTM to apply the load on specimen.

3. WORKING

1. To perform 3-point testing, the I-beam is mounted on the base Universal testing machine. Then two roller supports are bolted on I-beam and specimen is placed on these roller supports and the load is applied on the specimen using jig.

2. The specimen gets deflected due to force applied by the jig. This deflection is taken as δ .

3. By using δ we can find out R i.e radius of curvature of deformed specimen

4. By using flexural formula we can find stress (σ) or modulus of elasticity (E) of material.

Flexural test formula:

$$\sigma/y = E/R = M/I$$

Here I is moment of inertia of the specimen. M is bending moment, which can be calculated

$$M = W * (L/2)$$

Where, 'L' is span or effective length of the component.

4. DESIGN ASPECTS

4.1 Design of I-section:

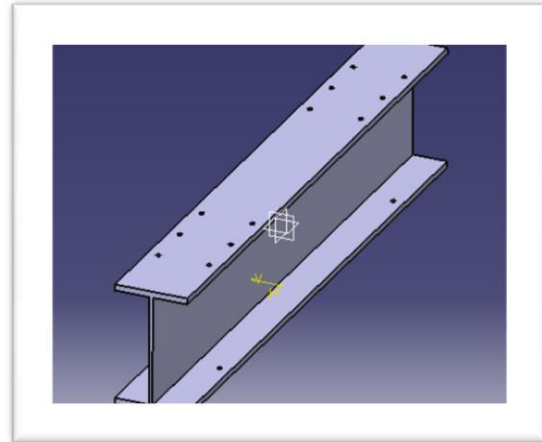

Fig.2 I-section

The bending moment is maximum for span length of 1000 mm for simply supported beam while it is 500 mm for cantilever. Thus we find induced bending and shear stresses in beam. The stresses developed should be in allowable stress limit.

For portable fixture maximum bending is at 600 mm span for simply supported condition and 500 mm span for cantilever condition.

4.2 Design of screw and nut for clamping:

We designed screw and nut considering crushing stress and checked for induced shear stress, bearing pressure for nut. For nut to be safe in shearing and crushing minimum eight threads are needed to be in contact. So length of nut is calculated as a product of pitch and no. of threads in contact which is 40mm.

4.3 Design of jig:

Consider slenderness ratio, jig is found as short column, so using rankine formula we design a jig,

The Rankine formula for short column,

$$P = \frac{\sigma_c * A}{1 + \alpha \left(\frac{Le}{k}\right)^2}$$

Diameter of jig is 30mm

4.4 Design of bolt on c-section:

Design of bolt is done by considering principle stress theory. The diameter thus found is 16mm

4.5 Design of bolt on I-section:

Bolt on I-section are subjected to tensile force and eccentric load, so after design we get bolt diameter as 16mm

4.6 Support attachment for cantilever and simply supported testing:

For simply support attachment we use gray cast iron while for cantilever we use spheroidal cast iron. We preferred spheroidal cast iron for cantilever since it has good strength in compression and tension. Thus we manufactured that attachment by using casting process and did surface finishing to get final dimensions as per our design.

5. ANSYS RESULTS

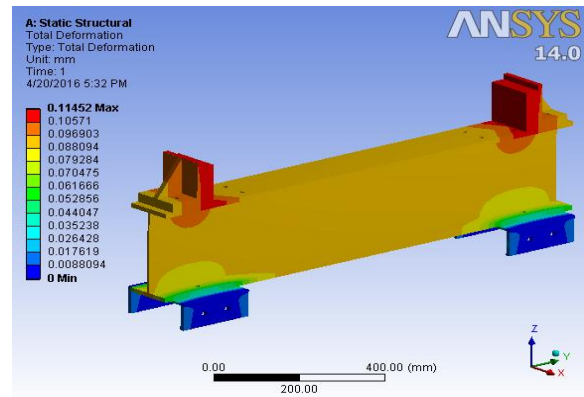

Fig.3 Simply supported ANSYS

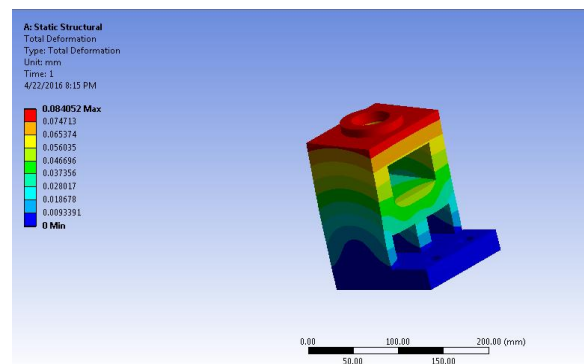

Fig.4 Cantilever attachment ANSYS

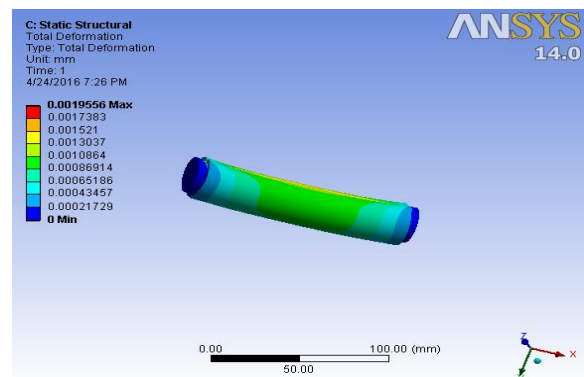

Fig.5 Support Roller ANSYS

6. ACTUAL ASSEMBLY

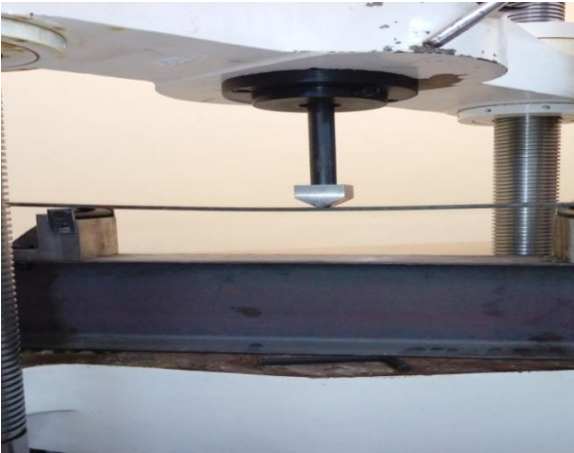

Fig.7 Three-Point Testing fixture on UTM

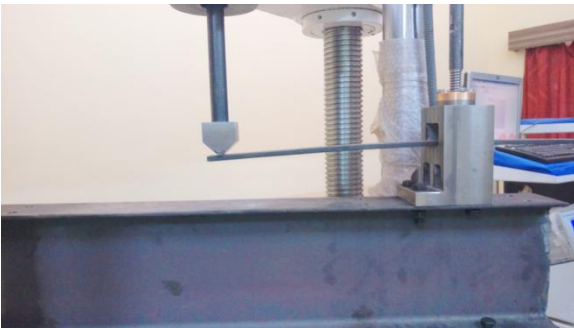

Fig.8 Two-Point Testing fixture on UTM



Fig.9 Three-Point Portable testing fixture

7. CONCLUSION

We performed 2-point and 3-point test with different spans on aluminium material. The results i.e. modulus of elasticity and bending stress obtained are within allowable limits.

8. FUTURE SCOPE:

1. The weight of assembly can be reduced by using different light weight materials having same strength.
2. By designing jig for four point loading condition we can also perform four point load test.
3. The machine can be designed for different span lengths.

9. REFERANCES:

- [1] R.K. Bansal, "*Strength of material*", Lakshmi Publications.
- [2] Bhandari, V. B., 2010, "*Design of Machine Elements*," Tata McGraw-Hill.
- [3] Bhandari, V. B, Design Data Book.
- [3] PSG Design Data Book for Mechanical Design