

Demand Response Based water Management System for Adaptive Power Optimization

KALPANA G S , NIRMALA L

MTech student, VLSI and Embedded Systems, Dept of ECE, Reva Institute of Technology and Management, Karnataka, India

Assistant Professor, VLSI and Embedded Systems, Dept of ECE, Reva Institute of Technology and Management, Karnataka, India

Abstract - we present a load measurement scheme for apartment management system with Adaptive power conservation and improving the reliability of pump motors based on concept of demand response. The proposed system will have the control on pile of water pumping motors, depending on the required water pressure for the circulation of water to all the buildings, the pump motors will be turned on and off. The microcontroller unit which is involved in the control action of the pump motors based on the sensor information. The system is having both the modes of operation fully automated and semi-automated using mat lab GUI model. The relative study of present system with the proposed system is presented using MATLAB .

Keywords: Load Measurement, Home Energy Management System, Demand Response

1.INTRODUCTION

The increasing demand of electrical energy has made electric Appliances to come across more frequent disturbance conditions. The common cause of system stress conditions include transmission line outages, which are likely to occur during critical peak hours. Such events will cause a supply-limit situation where cascading failures and large area blackouts are possible. Demand response (DR) has been visualized to deal with such unexpected supply limit events by selectively imposing a restriction on system loads, whereby regaining balance between electricity supply and demand. DR also plays an major role in load shifting that can help increase dependability and proficiency in operation [1].

In efficient use of electric power in terms of generation and transmission is a widespread problem all around the globe. For instance, in developing countries such as Pakistan, the electricity distribution system is riddled with a whole host of problems that are financial or technical in nature. The sheer deficiency of infrastructure to meet the demand has increased the severity of the problems. The ultimate solution to these problems would be developing and fostering more research developments in this field. Power distribution systems across the world are currently facing serious challenges due to a steep increase in electricity and one of the techniques used to alleviate this problem is load shedding. Load shedding is the art of maintaining the load

demand by shedding it in critical situations where demand power is increased than the total power generation to avoid major breakdown or system failures

In smart city applications such as apartments and shopping malls, IT Parks Etc., continuous water supply to be provided without interruption. It is not possible to maintain water in overhead tanks for such huge infrastructure. So in the present scenario water is pumped by the array of motors [24x7] irrespective of the requirement, which lead to the failure and repair of motors, power consumption is more.

2. PROPOSED SYSTEM

In this project it is been planned to implement an smart embedded system which can adoptively switch the motors on and off based on the demand request by the water flow and pressure sensors using embedded microcontroller[RL-78], which is the master controller for all input and output operations of the system. It is also been planned to plot and compare the system response with the present system using MATLAB GUI for different possible scenarios.

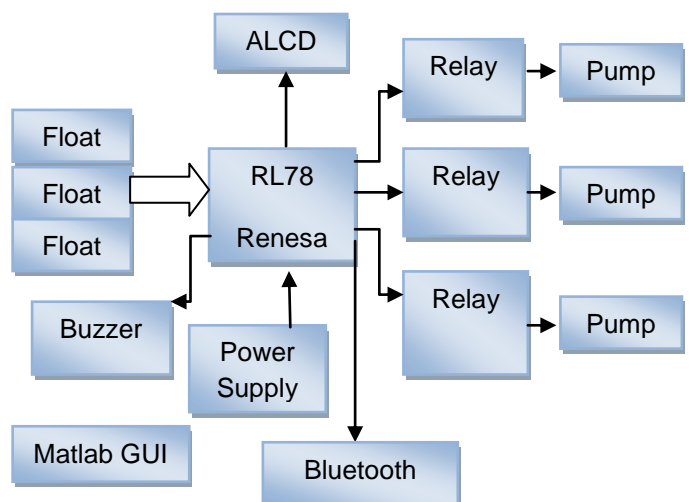

Fig-1: Block Diagram of Demand Response Based water Management System

3. COMPONENT DESCRIPTION & TOOLS USED

A.MICROCONTROLLER RL – 78

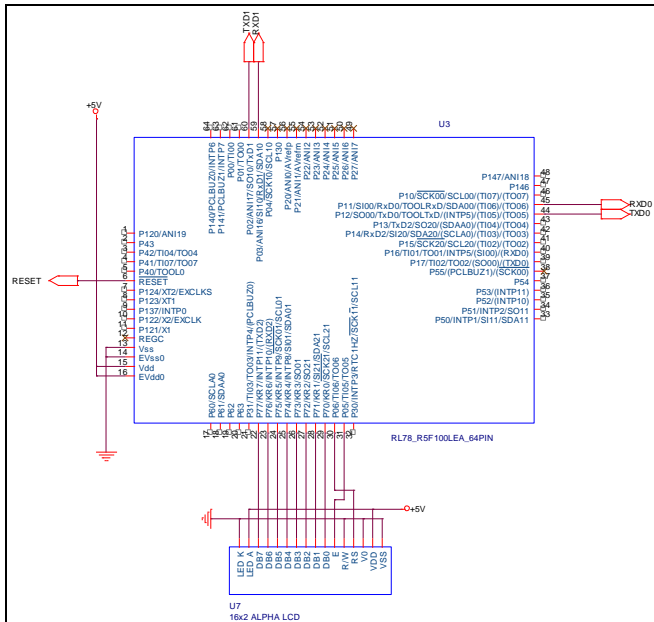

Fig-2: Renesas RL78[R5F100LE]

Target Devices: RL 78/G12 16 bit Single Chip Microcontroller General-purpose register: 8 bits × 32 registers (8 bits × 8 registers × 4 banks) ,Timer and serial interface UART programming

The microcontroller pins P137 and P16 are configured as interrupt pins which are used to count the number of pulses coming from the flow meter sensor output. Which is further used generate the trigger SMS for the MATLAB based processing. Pin numbers P5.0, P5.1, P5.5 are used as output pins to trigger the relays 1, 2, 3 respectively. Based on the microcontroller decision which motor to be turned on and off based on the requirement. Pin numbers P5.2, P5.3, P5.4 are used as input pins to the microcontroller which are used to interface with the IR sensors to get the obstacle information and further processing. The serial communication module UART1 of the microcontroller is used for serial communication between mat lab and the microcontroller.

B.ALPHA NUMERIC LCD DISPLAY

A liquid crystal display (LCD) is a flat panel display, electronic visual display, based on Liquid Crystal Technology. Interfacing JHD162A with microcontroller

The LCD used is 16x2, 2 rows and 16 columns. The Alpha Numeric LCD is used as a display device for temporary result debugger which intermediately display the working conditions such as relay on/off conditions, sensor on/off conditions etc. and flaw sensor output values etc.

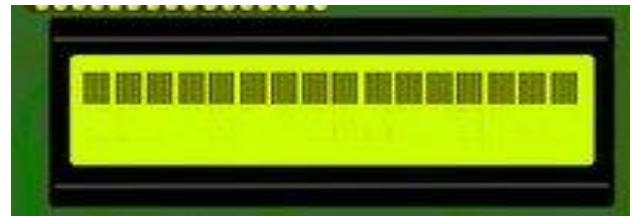

Fig-3: Alpha Numeric Display

C.RELAY WITH TRANSISTOR DRIVER

A relay is an electrically operated switch. Current flowing through the coil of the relay creates a magnetic field which attracts a lever and changes the switch contacts

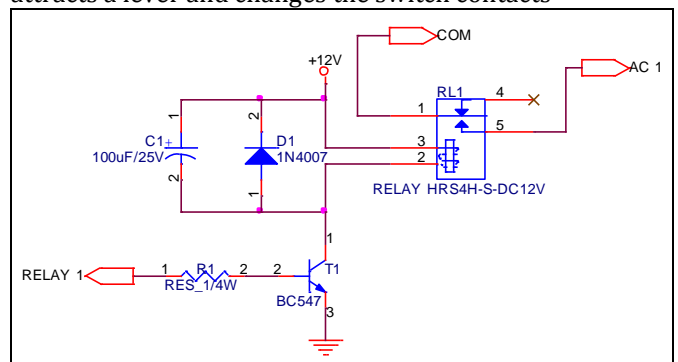

Fig-4: relay with transistor driver

D. IR TRANSMITTER & RECEIVER

LM358 is a dual op-amp IC , Whenever the light transmitted by the IR LED falls on the photo diode the current flowing through the reverse bias connected photo diode changes and the voltage across the resistive bridge changes and output of the op-amp becomes 1. Which can be used by the microcontroller pin for further processing.

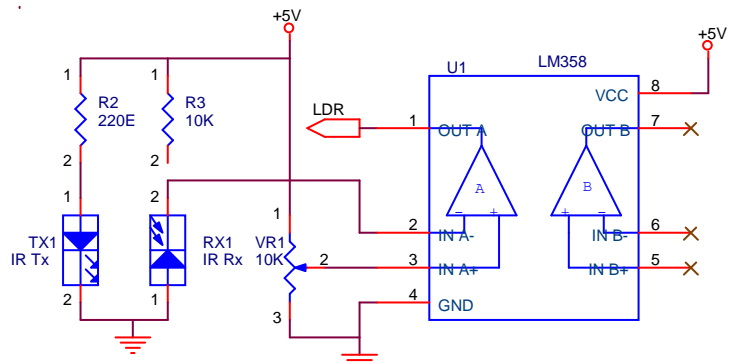

Fig-5: Two sets of LM358 IC – Comparator Circuit

E. FLOW SENSOR

A flow sensor is a device for sensing the rate of fluid flow. Typically a flow sensor is the sensing element used in a flow meter, or flow logger, to record the flow of fluids. As is true for all sensors, absolute accuracy of a measurement requires a functionality for calibration. Here the flow sensor is connected to the motor 1 and motor2 of our project ,whenever the water flow from the motors the flow rate is measured and sent to the microcontroller interrupt pins P13.2 and P1.6 which are used for motor1 and motor2 respectively. Based on the water flow the number of pulses are generated by the flow sensor the microcontroller interrupt counts and sends to the MATLAB GUI for further processing.

F. TOOLS USED

The various tools used to conduct the experiments of this proposed work are : Embedded C , Cube suite+ & Matlab 2014a

Embedded C: Required codes are written using Embedded C
 Cube suite+ : Integrated development environment CS+ offers **the** ultimate in simplicity, usability, and security for the repetitive editing, building and debugging that typifies software development.

Matlab 2014a : GUIs created using MATLAB tools can perform computation , Read & Write data files , communicate with other GUIs, and display data as tables or as plots

4. WORKING OF PROPOSED MODEL

As soon as the power is given to the circuit the microcontroller is switched on and all the peripherals are initialized to their respective input /output configuration. The microcontroller [R5F100LE] will start scanning the input tap sensors. We have planned 3 tap sensors by using Infra-red obstacle sensors. As soon as an obstacle is detected by the sensor the output of the comparator LM358 will generate logic 1 to the Microcontroller, On receiving logic 1 the microcontroller will send the trigger pulse to the relay number 2 to provide the power to the relay number1 [[5v] On receiving the 5 v supply the motor driver relay no1 will start the motor1 with low speed configuration. If one more tap sensor is detected then the same relay number 2 will generate the 12v supply to the relay number 1, such that the motor1 will run with the high speed so that more water will get pumped. If Tap sensor number 3 is detected then the microcontroller will generate the start pulse to the relay number 3 which directly drives the motor no 3 with low speed.

All the above control actions are coordinated under the surveillance of the microcontroller. All the intermediate results are visually displayed using 16*2 Alphanumeric LCD display. On the other hand the flow meter sensors are used to detect the flow rate which will generate the series of pulses that are counted by the microcontroller using watchdog timer and the string of data is sent to the MATLAB GUI via RS 232 port of PC .Based on data received the MATLAB GUI will evaluate the motor1 and motor 2 flow rate values and plot the graph by taking the time vs motor usage.

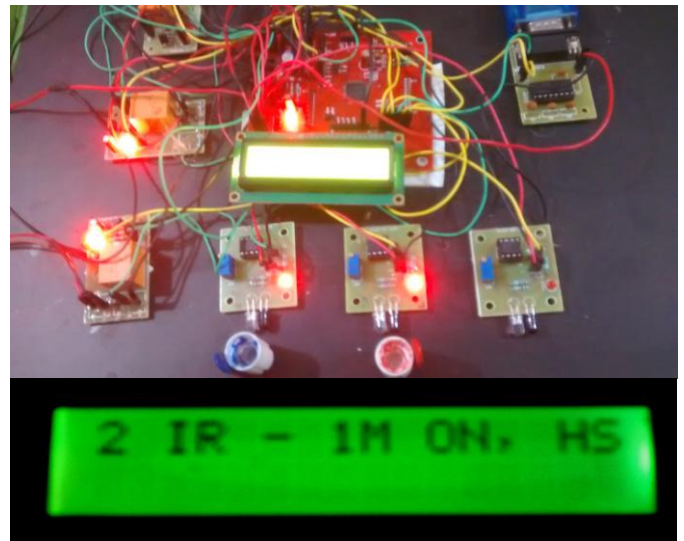

Fig-6: Working model with two sensors are ON

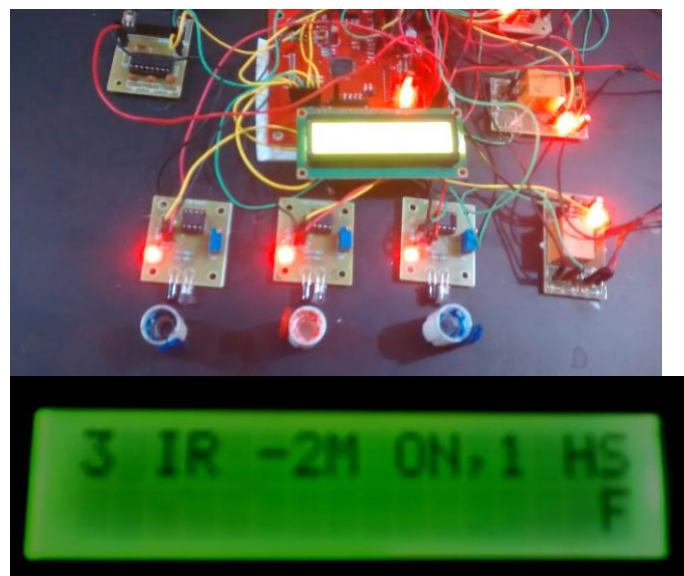

Fig-7: Working model with three sensors are ON

5. RESULTS

The simulation results have been compared for normal mode and demand mode of operation in MATLAB GUI. We can also correlate the conventional system with the proposed system.



Fig-8 : Graph Time V/s Motor usage – Two Sensors are ON

Experimental results when the sensor no.1 and no.2 are triggered and MAT LAB results indicated at value 08 (Red line) as compared with conventional system (Green line)



Fig-9: Graph Time V/s Motor usage – Three sensors are ON

Experimental results when the sensors no.1, no.2 and no.3 are triggered and MAT LAB results indicated at value 08 (Red line) and 03 (Blue line) as compared with conventional system.

6. CONCLUSION AND FUTURE WORK

The smart home energy management system is designed to use the energy efficiently and avoid the waste of energy and improve the reliability of the device [Pump Motors]. Demand response based energy use helps to reduce risk of energy price fluctuations and supply shortages.

The future enhancement of the project is to drive the AC real time pump motors with the same relay drivers and implement the system.

ACKNOWLEDGEMENT

I take this opportunity to express my gratitude and sincere thanks to Ms. Nirmala L Asst Professor, Department of Electronics and Communication, REVA Institute of Technology & Management, Bangalore, Karnataka, INDIA who was my internal guide and provided me with timely inputs for completing my project successfully, encouraged me throughout the course of the Master's Degree.

REFERENCES

- [1] DOE-EIA, "Energy efficiency and renewable energy. International energy outlook," 2011 [Online]. Available: [http://205.254.135.24/forecasts/ieo/pdf/0484\(2011\).pdf](http://205.254.135.24/forecasts/ieo/pdf/0484(2011).pdf)
- [2] M. Albadi and E. El-Saadany, "Demand response in electricity markets: An overview," in Proc. Power Eng. Soc. Gen. Meet., Jun. 2007, pp. 1-5.
- [3] Federal Energy Regulatory Commission, "Assessment of demand response and advanced metering," Feb. 2011 [Online]. Available: <http://www.ferc.gov/legal/staff-reports/2010-dr-report.pdf>.
- [4] P. Xu, P. Haves, M.A. Piette, and L. Zagreus. Demand shifting with Thermal mass in large commercial buildings: Field tests, simulation and audits. 2005.
- [5] J.E. Braun. Load control using building thermal mass. Journal of solar energy engineering, 125:292, 2003.
- [6] K. Clement-Nyns, E. Haesen, and J. Driesen. The impact of charging plug-in hybrid electric vehicles on a residential distribution grid. Power Systems, IEEE Transactions on, 25(1):371-380, 2010.
- [7] J. Lu, D. Xie, and Q. Ai, "Research on Smart Grid in China," IEEE Transmission Distrib. Conf. Exposition: Asia Pacific, Seoul, Rep. of Korea, Oct. 2009, pp. 1-4.
- [8] L. Peretto, "The Role of Measurements in the Smart Grid Era," IEEE Instrum. Meas. Mag., vol. 13, no. 3, June 2010, pp. 22-25.
- [9] G. Xiong et al., "Smart (In-Home) Power Scheduling for Demand Response on the Smart Grid," IEEE PES Conf. Innov. Smart Grid Technol., Anaheim, CA, USA, Jan. 2011, pp. 1-7.