

# Voice and Gesture Based Wheelchair for Physically Challenged Using AVR and Android

Revati A. Solanke<sup>1</sup>, Arti R. Salunke<sup>2</sup>

<sup>1</sup>Post Graduate Student, Department of Electronics Engineering, JNEC, Aurangabad, Maharashtra, India

<sup>2</sup>Assistant professor, Department of Electronics Engineering, JNEC, Aurangabad, Maharashtra, India.

**Abstract** - This paper is to describe an intelligent wheelchair for handicapped or elderly person (user) using inputs such as gesture and voice commands via an android phone. Using wheelchair, user can move without external aid to anywhere they want, simply by uttering the direction name or by making the movement of the android phone they will be provided with. It is also equipped with obstacle avoidance facility, where the person may not be able to provide proper command at the right time. If the user feels to be found in danger, a security threat message can be sent through the mobile phone to predefined number.

**Key Words:** Wheelchair, gesture, voice commands, handicapped, android

## 1. INTRODUCTION

With the increase of aged and disabled people, a large variety of support devices and modern equipment has been build up to help improve their quality of life. Some patients which cannot control the wheelchair with their arms due to a lack of force face main problems such as orientation, mobility, safety [5]. The general image of disability is the people in wheelchairs. Wheelchairs are used by people who find themselves unequipped to move without outside aid. The special needs of the elderly may differ from that of a handicapped person or a large individual but they all have "special needs" and often require some support to perform their daily routine.

The handicapped people, who use a normal wheelchair for navigation, usually need an external person to move around. In this busy world, the elderly people may be left alone at home and also may not find an apt person for external help. Here comes the need of an automated home navigation system, which consists of a wheelchair which can be used by the elderly and the handicapped people without the help of an external person.

The proposed Home Navigation System (HNS) can be operated using voices and the gestures of the provided android mobile phone. An essential feature is that the

personal security of the person who is using the wheelchair is also taken care. If the person feels insecure or uncomfortable, he can send a message to a predefined number using the speech to text (STT) function in the mobile phone.

## 2. RELATED WORK

It is reviewed that although some current wheelchair systems have embedded computers, they have very little computer control and require precise, low-level control inputs from the user; interfaces are similar to those found in passenger cars. creators developed a smart wheelchair with intelligent controllers that let people with physical disabilities overcome these difficulties. By outfitting the wheelchair with cameras, a laser range finder, and on-board processing, we give the user an flexible, intelligent control system. Account of the high risk of accidents with people and objects is taken in [2].

This paper explains and presents the preliminary results of a system that uses an infrared sensor to provide anti-collision and a prompting system for a powered wheelchair that helps guide the user safely past obstacles. Paper [3] focuses on the navigation and guidance system of a powered wheelchair. We have developed a navigation unit with different levels of autonomy which realizes an active interaction of the user with the robotic aid.

A wheelchair for handicapped people developed within the UMIDAM I Project is explained in [4]. A needy-user recognition voice system and ultrasonic and infrared sensor systems has been included in this wheelchair. In this way we have acquired a wheelchair which can be driven autonomously or with using voice commands and with the possibility of avoiding obstacles and downstairs or hole detection. Paper [5] describes the wheelchair system with user friendly touch screen interface. The ability to choose between manual operating mode and predefined operating mode uniquely presents capacity of the wheelchair to operate in multiple environments.

### 3. PROPOSED ALGORITHM

#### 3.3 Flow Chart of The Voice and Gesture Based Wheelchair

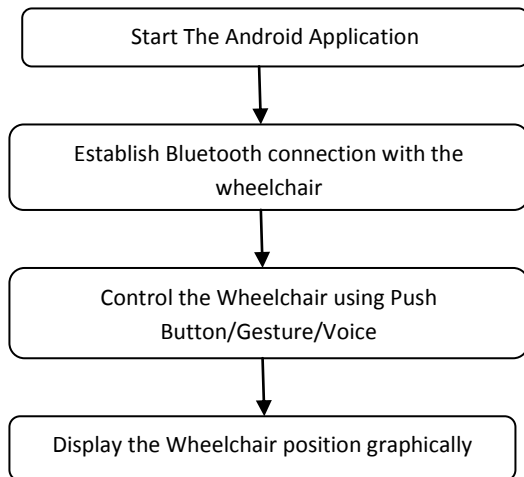

### 4. SYSTEM DESIGN

Here we can understand the construction and working of the model. System uses an Android phone to communicate with the wheelchair and a desktop computer is used to observe the position of the wheelchair.

#### 4.1 Hardware Description

The hardware consists of various components such as AVR ATmega32, a Bluetooth device, motor driver which is L293D, IC ULN2803, external device such as torch, two dc motors of 5 rpm each, MAX232 for serial communication between AVR and Bluetooth, four sensors for temperature, smoke, obstacle distance and light along with an android phone and a remote computer which are explained one by one below.

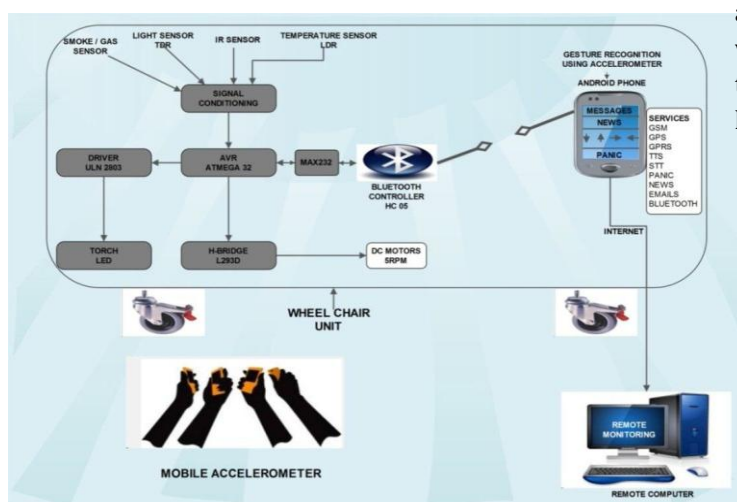

Fig -1: Block Diagram

#### 1. ATmega32

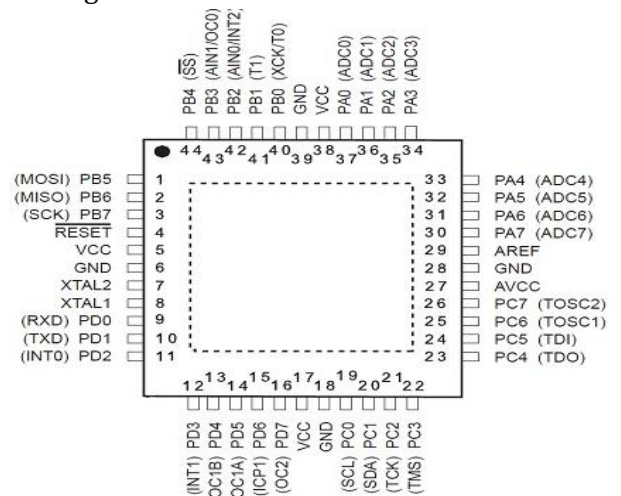

Fig-2: ATmega32 Pinout

Fig 2 is the pinout diagram of the ATmega32 controller. The ATmega32 is a low-power CMOS 8-bit microcontroller based on the AVR improved RISC architecture. By executing powerful instructions in a single clock cycle, the ATmega32 gets throughputs approaching 1 MIPS per MHz allowing the system designers to optimize power consumption versus processing speed.

#### 2. L293D

L293D is a dual H-bridge motor driver integrated circuit IC (integrated circuit). Motor drivers work as current amplifiers since they take a low-current control signal and provide a higher-current signal. This advanced current signal is used to steer the motors. Figure 3 below is the pin diagram of L293D. Enable pins 1 and 9 (matching to the two motors) should be high for motors to start operating. When a facilitate input is high, the associated driver gets enabled. As a consequence, the outputs become active and work in phase with their inputs. Similarly, when the facilitate input is low, that driver is disabled, and their outputs are off and in the high-impedance state.

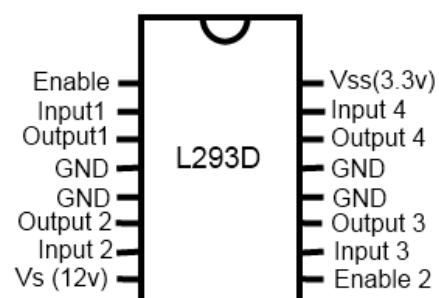

Fig-3: L293D Pinout

Generally, L293D motor driver can control two motor at one time or called is a dual H-Bridge motor driver. By using this Integrated circuit (IC), it can interface DC motor which can be controlled in both counter clockwise and clockwise direction. The motor operations of two motors can be controlled by input at pins 2 & 7 and 10 & 15. Below is shown the pinout diagram of L293D motor driver.

Besides that, with this L293D driver motor it will control 4 DC motors at 1 time but with fix direction of motion. L293D has peak output current of 1.2A and output current of 600mA per channel. Moreover for safety of circuit from back EMF output diode are included within the L293D. The output supply which is external supply has a extensive range from 4.5V to 36V which has made L293D a best choice for DC motor driver. A simple diagram for interfacing a DC gear motor using L293D driver motor is shown below

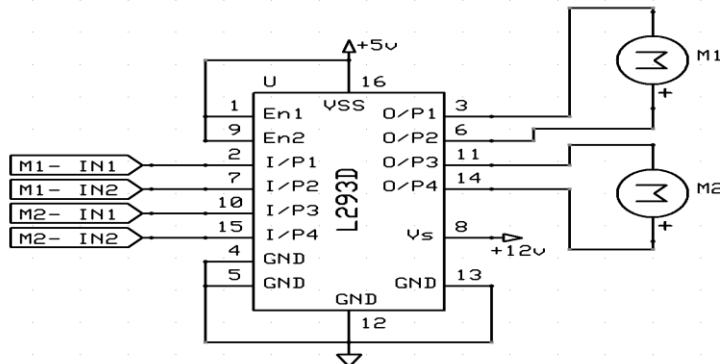

Fig-4: Schematic for Interfacing a DC Gear Motor Using L293D Driver Motor

### 3. MAX232

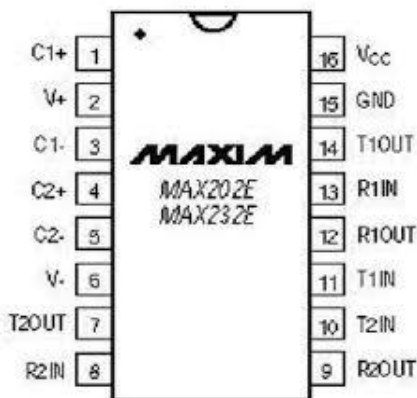

Fig-5: MAX232 Pinout

The MAX232 IC is used to convert the TTL/CMOS logic levels to RS232 logic levels during serial communication of microcontrollers with PC. The controller operates at TTL logic level (0-5V) whereas the serial communication in PC works on RS232 standards (-25 V to + 25V). This makes it

hard to establish a direct link between them to communicate with each other. The in-between link is provided through MAX232. Above fig 5 is the pin diagram of MAX232.

### 4. ULN2803

Featuring continuous load current ratings to 500 mA for each of the drivers, the Series ULN28xx high voltage, high-current Darlington arrays are ideally suited for interfacing between low-level logic circuitry and multiple peripheral power loads. Typical loads consist of relays, solenoids, stepping motors, magnetic print hammers, multiplexed LED and incandescent displays, and heaters. Please refer fig 6 below for the pin description of the ULN2803.

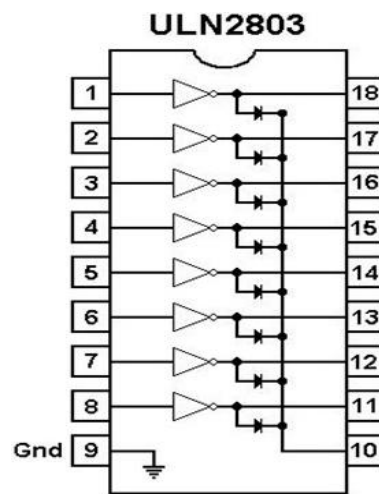

Fig-6: ULN2803 Pinout

### 5. Sensor

There are four sensors used- proximity, smoke, temperature and light. Proximity and smoke detection uses Infrared technique, temperature is detected by thermistor and light using LDR.

### 6. HC 05 serial port Bluetooth module

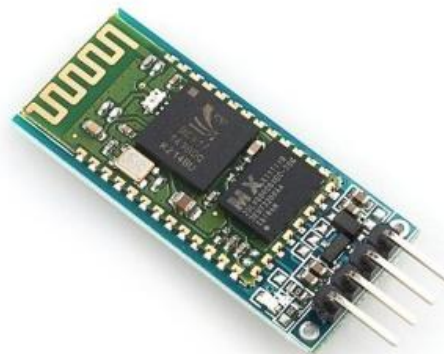

Fig-7: HC 05 serial port Bluetooth module

HC-05 module is a simple to use Bluetooth SPP (Serial Port Protocol) module, designed for transparent wireless serial connection setup. Serial port Bluetooth module is completely qualified Bluetooth V2.0+EDR (Enhanced Data Rate) 3Mbps Modulation with complete 2.4GHz radio transceiver and baseband. It uses CSR Blue core 04-External only chip Bluetooth system with CMOS technology and with AFH(Adaptive Frequency Hopping Feature). It has the footprint as small as 12.7mmx27mm. Hope it will simplify your overall design/development cycle. Figure 7 is the Hc 05 serial port Bluetooth module image.

### 7. Power Supply Unit

The +5 volt supply is useful for both analog and digital circuits. DTL, TTL, and CMOS ICs will all operate nicely from a +5 volt supply. In addition, the +5 volt supply is useful for circuits that use both analog and digital signals in various ways. More importantly for our purposes, the +5 volt supply will be used as the primary reference for regulating all of the other power supplies we will build. We can do this very

### 4.2 Circuit Diagram

We have already discussed the working of the components which can be seen in the circuit diagram. This is all about

simply if we use opamp ( operational amplifiers) as the controlling elements in the power supply circuits.

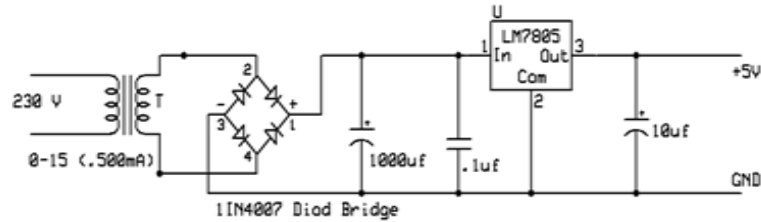

Fig-8: Schematic Diagram- Power Supply 5V

The +5 volt power supply is based on the commercial 7805 voltage regulator IC. This IC contains all the circuitry needed to accept any input voltage from 8 to 18 volts and produce a steady +5 volt output, accurate to within 5% (0.25 volt). It also contains current-limiting circuitry and thermal overload protection, so that the IC won't be damaged in case of excessive load current; it will reduce its output voltage instead

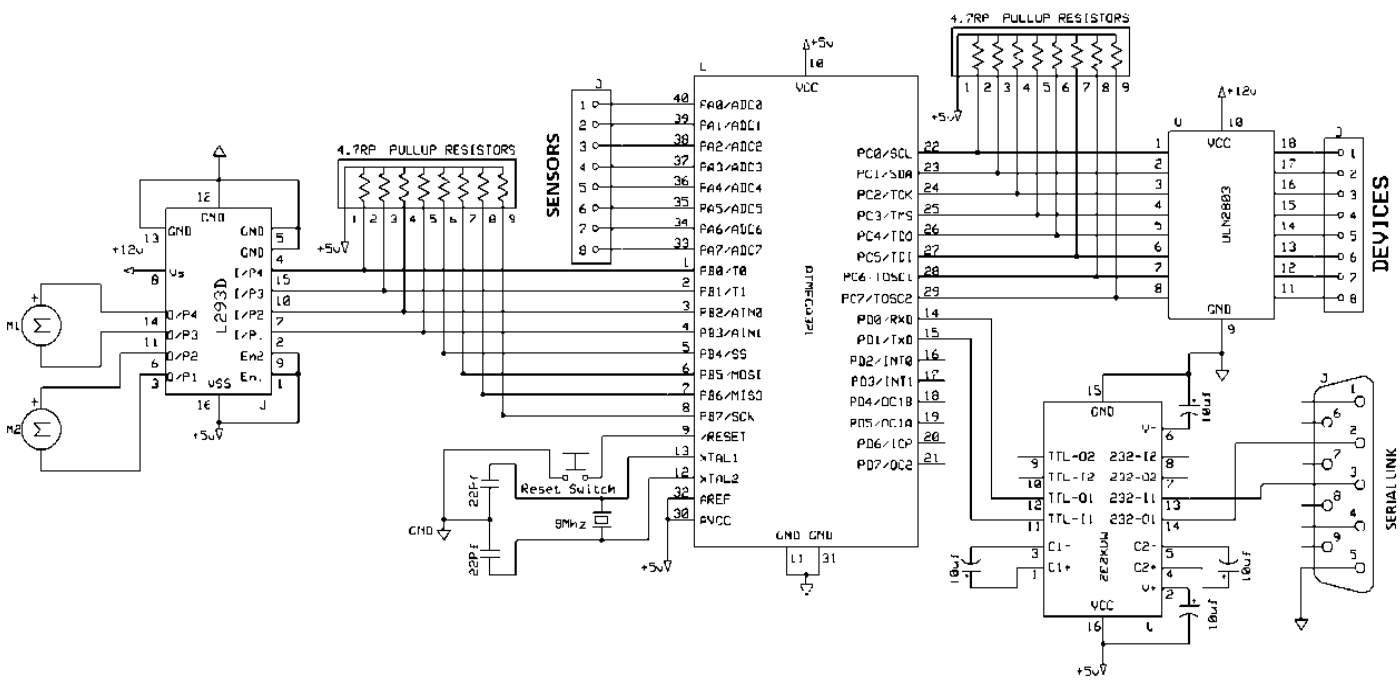

Fig-9: Circuit Diagram of the Wheelchair model

### 4.3 Software Description

In the Software part of this system, first comes the android. This is a Linux-based operating system mainly designed for mobile devices such as smart phones and tablet computers utilizing ARM processors, uses Java as the programming language. NetBeans are well known to make the Graphical User Interface of the android application. Lastly to communicate to a remote monitoring desktop, Servlets are used.

## 5. PERFORMANCE ANALYSIS

### 5.1 Systems Performance Analysis

There are 4 GUI (Graphical user interface) screens in this android application. Working of each is explained below-

Screen 1- Enter the IP address of remote monitoring desktop (Refer fig 10)

Screen 2- url of the news website, email id and password (Refer fig 11)

Screen 3- To connect via Bluetooth to wheelchair (Refer fig 12)

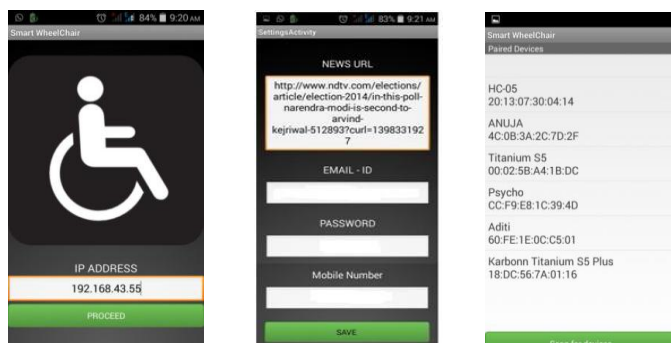

Fig-10: I<sup>ST</sup> Screen    Fig-11: II<sup>nd</sup> Screen    Fig-12: III<sup>rd</sup> screen

### 5.2 GUI screens of the Android Application

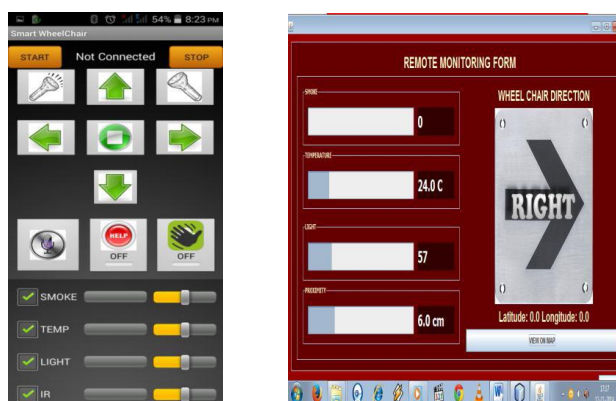

Fig-13: 4th GUI Screen    Fig-14: Remote Desktop Monitoring

On the fourth screen (refer fig 13), actual operation of the wheelchair is controlled. Here the movement of wheelchair is controlled in three modes- Push buttons, Gesture of the handset and voice. Buttons for sending a help seeking message and torch are also provided.

### 5.3 Monitoring on remote Desktop

Here on the remote desktop (refer fig 14), we can observe the 4 sensor values as shown in above photo. Secondly, the current movement of the wheelchair and the latitude and longitude locations can be observed. Along with this, a link to Google Map is given which can shows the position of the wheelchair on the Google map.

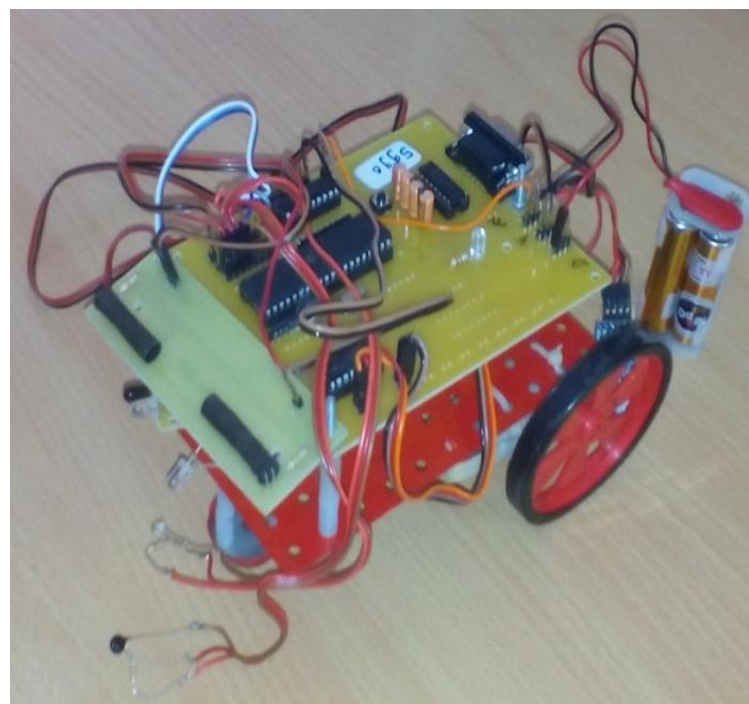
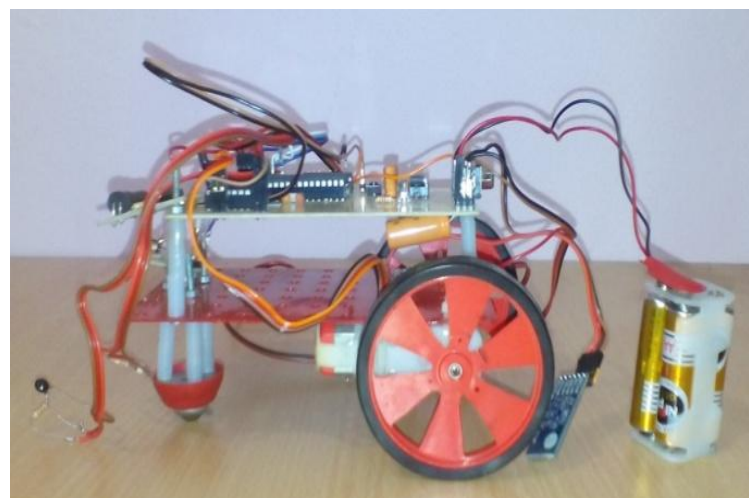

Fig-15: Proposed System Hardware

## 6. CONCLUSION

Here we have tried to render a wheelchair for both elderly and the physically challenged with a varied physical disability. Those who can't speak, but have their hands in working condition, can use the push buttons. Those who can't see on the screen of mobile phone, but once again, have their hands in working condition, can use the gesture controlled input where just by tilting the handset. Lastly, those who can pronounce a word can directly pronounce the command and navigate the chair.

## ACKNOWLEDGMENT

I highly indebted to **Mrs. A. R. Salunke** (Assistant Professor at JNEC, Aurangabad) for her valuable guidance and constant supervision as well as for providing valuable information. I would also like to express my particular gratitude and thanks to her for giving us such attention and support.

## REFERANCES

- [1] Sarangi P. Parikh, ValdirGrassi Jr., Vijay Kumar, Jun Okamoto Jr., "Integrating HumanInputswithAutonomousBehaviorson an IntelligentWheelchair Platform", IEEE Computer Society-Vol. No. 22, Issue No. 02, pp. 33-41, march/April 2007.
- [2] Mihailidis A, Elinas P, Boger J, Hoey J., "An Intelligent Powered Wheelchair To Enable Mobility Of Cognitively Impaired Or Adults: An Anti-Collision System", Neural Systems and Rehabilitation Engineering, IEEE Transactions- Vol. No. 15, Issue No. 01, pp. 136-143, March 2007.
- [3] S. Fioretti, T. Leo, and S. Longhi, "A Navigation System for Increasing the Autonomy & the Security of Powered Wheelchair", IEEE Transactionson Rehabilitation Engineering, Vol. No. 8, Issue No. 4, December 2000.
- [4] Manuel Mazo, Francisco J. Rodriguez, Josi L. L, Zaro, Jesi Is Urei A, Juan C. Garcia, Enrique Santiso, Pedro Revenga and J. Jesi Is Garcia,
- [5] Ming-Ching Tsai; Kai-Sheng Wu; Po-Wen Hsueh. "Synchronized Motion Control for Power-Wheelchairs" Proc Int'l Conf. Innovative Computing, Information and Control (ICICIC), Dec. 2009, pp. 908-913.
- [6] Vasundhara G. Posugade, Komal K. Shedje, Chaitali S. Tikhe, "Touch-Screen Based Wheelchair System", ISSN: 2248-9622 Vol. 2, Issue 2, pp.1245-1248, Mar-Apr 2012
- [7] [http://www.ijrcce.com/upload/2014/december/6\\_Voice.pdf](http://www.ijrcce.com/upload/2014/december/6_Voice.pdf). Padhye, V. Firoiu, and D. Towsley, "

## BIOGRAPHIES



Revati A. Solanke  
She is an Electronics and Telecommunication Engineer. She received her B.E. degree in Electronics and Telecommunication engineering and currently pursuing M.E. (Electronics Engineering) from MGM's JNEC College, BAMU, Aurangabad, Maharashtra, India.  
E-mail: revatijachak@gmail.com



Arti R. Salunke  
She is Assistant Professor in Jawaharlal Nehru College of Engineering, Aurangabad, India She got her Master's degree in Electronics. She is pursuing Ph.D. degree in Mobile communication under the guidance of Dr. Arun N. Gaikwad, Principal, Zeal Education Society's Dnyanganga College of Engineering and Research, Narhe, University of Pune.  
E-mail: aartithakur1@gmail.com.