

INTEGRATION OF AIML CHATTER BOT FOR NEWS APPLICATION ON WHATSAPP

Rinkal D. Dharani¹, Dr. A.C. Suthar²

¹ME student, L.J. Institute of Engineering & Technology, Ahmedabad, 382210, INDIA

² Director of L.J. Institute of Engineering & Technology, Ahmedabad, 382210, INDIA

Abstract – Millions of People daily using digital media for getting latest NEWS around the world. In this digital ERA, every person is using his/her multimedia phone to receive NEWS update by some 3rd party applications. Such 3rd party applications are too much bulkier in size and it also slow down our phones by flashing ads all over application work place. WhatsApp is a most demanding 3rd party instant messages service in last decade. It's very fast, low space consumption, No Advertisement and the main benefit is everyone is already installed this application in their smart phone. So, no need to install any extra application in your smart phone. We planning to implement an AIML based Chatterbot with WhatsApp application. The Artificial Intelligence Markup Language (AIML) is a XML compliant language. (Extensible Markup Language). It will receive request from users and send them latest update in desired category 24*7. We will configure Apache Server on Raspberypi. Raspberypi is a credit card size computer with 512 RAM, 700 Mhz ARM 11 processor, 4 USB ports and a MMC card slot for installing OS on Board. We will use Mysql database for managing all data flow. Mysql stores data as well as user conversations in it. In this paper work hilted only towards AIML.

Key Words: Artificial Intelligence, Chatterbot, ALICE, Pattern Recognition, Artificial Intelligence Markup Language (AIML).

1. INTRODUCTION

In the current globalized society, the expanding advancement and spread of Information Innovation and the Internet have prompted the making of unmistakable methods for correspondence among clients in virtual situations. In this setting, the psychological interfaces give new types of cooperation in the middle of human and machine. We make chatterbot using AIML. In a chatterbot, conversation for the most part happens by the trading of instant messages (as in a visit domain), and the chatterbot is composed to give includes that permit the use of normal dialect, such as dealing of questionable circumstances and connection based message investigation (taking into account

Pragmatics). Currently, the chatterbots has been connected in the most changed purposes. For instance, the entertainment chatterbots that are intended to excite and to entertain the client while keeping up a rational conversation. The Artificial Intelligence Markup Language (AIML) is made, in light of the ideas of Pattern Recognition, or Matching Pattern method. It is connected to normal dialect displaying for the dialog in the middle of people and chatterbots that take after the joint reaction approach. For this reason an arrangement of conceivable client inputs is displayed and, for every one of these sentences (boosts), pre-modified answers were worked to be appeared to the client. The ALICE (Artificial Linguistic Internet Computer Entity) chatterbot was the first to utilize the AIML dialect and mediator. In ALICE, the AIML innovation was in charge of example coordinating and to relate a client data with a reaction of the chatterbot's Knowledge Base (KB). In the writing that exhibits the AIML ideas, there are instructional exercises that externally present such ideas [1][2], or present the dialect ideas in point of interest [1][2]. The two alternatives are most certainly not suitable for AIML apprentices since they can't adjust the measure of hypothesis and application.

Also, another works concentrate on the use of Pattern Recognition strategies, and the AIML dialect itself is tended to as an optional subject. In this work an AIML dialect instructional exercise is introduced, ideas of Pattern Recognition are considered, yet the principle thought is to have a reference guide for AIML dialect's beginning studies.

2. CHATTERBOT DEVELOPMENT

Among the theories and technologies used to develop chatterbots, the Pattern Recognition is an example which aims to model computer systems based on the format of human dialogs. The Pattern Recognition is based on representative stimulus-response type blocks, which the user enters a sentence (stimuli) and the software makes an output (response) according to the user input. For that Pattern matching Algorithm used. [1][13].

There are AIML syntax and semantic for development of chatterbot [1][2]. Technically speaking, AIML objects are language tags, and each tag corresponds to a language

command. The general form of an AIML object/command/tag has the following structure:

```
<command> List Of Parameters </command>
```

An AIML command consists of a start tag (<command>), a closing tag (</command >) and a text (List Of Parameters) that contain the command's parameter list. Also have some Tags for creation of chatterbot which are very usefull in it [2].

A chatterbot development platform provides the AIML interpreter, as well as a set of integrated technologies, to reduce the cost and the complexity of development, deployment and management of such systems. Some of technologies that can be pointed out are the database integration, Web services for an online chatterbot and the log recording of the conversations with the users. Some development platforms are presented below:

Program consists of an API (Application Programming Interface) implemented in Java, PHP Among the advantages of using Program there are (i) the distribution of the source code files and (ii) a KB that can be used for testing and analysis during the AIML language learning, as well as to develop chatterbots;

3. CHATTERBOT BASED ON AIML



Fig -1: A.L.I.C.E.

A chatterbot is a type of conversational agent, a computer program designed to simulate an intelligent conversation. It processes the users' inputs in natural language and consults its knowledge base to make a response that imitates the human's one.

AIML is an XML based programming language that, as we comment above, was specifically designed to help in the development of A.L.I.C.E., and it is widely used in the development of software agents that communicate with their users in natural language.

AIML is a text file with a specific structure, which constitutes the knowledge base of the chatterbot. The "categories" are the fundamental knowledge basis, and they consist of at least two elements: the "pattern" and the "template".

In general, the performance of AIML is based on a stimulus-response model, in which the stimulus (the user's input) corresponds with the "pattern", and the response (which the chatterbot will show to the user) will be its associated "template" (see Figure 2).

```
<category>
  <pattern>
    <!-- possible user's input -->
  </pattern>
  <template>
    <!-- chatterbot response-->
  </template>
</category>
```

Fig -2: AIML Example

4. AIML CHATTERBOT ON WHATSAPP FOR NEWS

Step

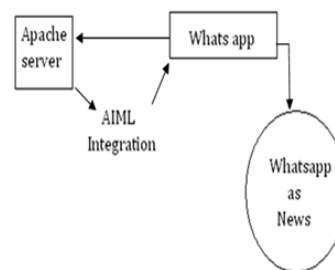

- Whatsapp install in apache server
- Number Register
- Testing Connectivity
- Database Connectivity
- AIML Integration
- Question by user
- Finding Answer & Entry in Database
- Sending answer.

Fig -3: AIML Bot Integration with Whatsapp

In this section shows how AIML work with Whatsapp. Block diagram shows integration Of AIML on Whatsapp and it will work as a chatterbot. Also news server is connected with Whatsapp server that's why user and bot can talk easily using natural language. After integrating chatterbot user can ask question to bot and it will give answer of that questions.

4.1 Hardware / Software Section (AIML Interfacing with CPU)

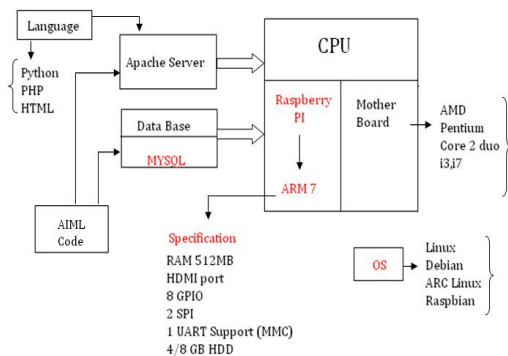

Fig -4: System Block diagram

Here first Creating database for chatterbot then Start Raspberry Pi and Boot up all functions. Then in one SD card Install the Apache2 web server also, Install the PHP programming environment then Install the My SQL database management system, Install PHP My Admin. Now Create a Virtual Host with MMC then Connect Hardware component. Give data connection with Wi-Fi Router and Install whatsapp in apache. Now one Number Register for chatterbot of NEWS and Testing Connectivity and Integrate AIML script on whatsapp. Now user ask Question so, bot will Finding Answer & Entry in Database and Sending answer.

5. SYSTEM WORKING DIAGRAMME

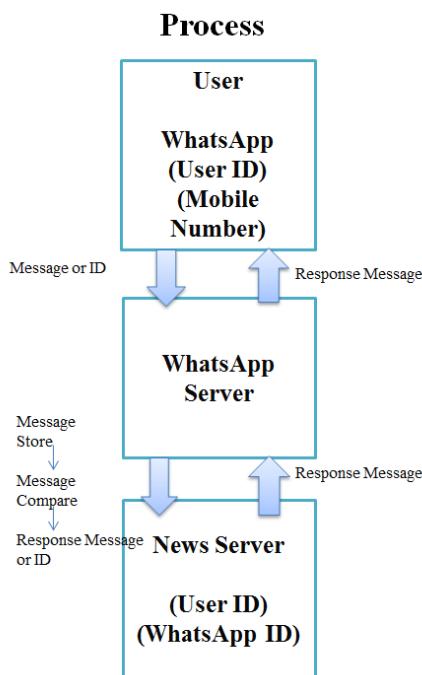

Fig -5: Block Diagramme Of Working On Whatsapp With Chatterbot

This work is based on server scripting. We can use PHP for scripting and in this we use AIML language which is an Artificial intelligence markup language. With help of AIML we create chatterbot of NEWS which talk with user using natural language. Conversational data will stored in tabular form in the mysql database. For the testing of the chatterbot with application we use Raspberypi, which have useful configuration. So that using Raspberypi we can able to test our chatterbot. Now user and bot are able to talk with each other for News.

6. CONCLUSIONS

In this Paper highlighted the importance of the conversational software development, more specifically the chatterbots as computational agents to establish natural language dialogs between humans and machines. The AIML language is one of the most widely used technologies for chatterbots implementation that combines the technical and theoretical Pattern Recognition's infrastructure in its development.

Also it highlighted Hardware and software with pattern recognition chatbot. It is based on representative stimulus response blocks. Chatbot are effective tools when it comes to education-commerce, Information section, etc. The aim of Chatbot designers should be: to build tools that help people, facilitate their work, and their interaction with Embedded Hardware using natural language like Smartphone's Apps. Here highlighted the work of Integration of AIML bot for NEWS on Whatsapp.

ACKNOWLEDGEMENT

I have taken efforts in this work .However it would not have been possible without the kind support and help of many individual. I would like to extend my sincere thanks to all of them. I am highly indebted to Dr. A.C.Suthar for his enlightening guidance, enthusiasm and constant supervision. I really appreciate his effort to review my report, give insightful comments and discuss with me when I am confused.

REFERENCES

- [1] Rinkal Devendrakumar Dharani, "Integration Of AIML Bot On Conversational Agent For The Different Application" National Conference on Emerging Reserch Trends in Engineering -NCERTE 2016. Pages 444-448.
- [2] Maria das graças bruno marietto, rafael varago de aguiar, gislene de oliveira barbosa, wagner tanaka

- botelho, edson Pimentel, "Artificial Intelligence Markup Language: A Brief Tutorial" International journals of Computer science and Engineering survey (TIN2013-68125-C02-02) .IJCSSES 2013
- [3] Fernando a. Mikic, juan C. Burguillo, martín llamas, "CHARLIE: an aiml-based chatterbot which works as an interface among INES and humans telematics engineering department, university of vigo E.T.S.I." Telecomunicación, campus lagoas marcosende s/n, 36310, vigo (pontevedra), spain DOI: 10.1109/EAAEIE.2009.5335493 Conference: EAAEIE Annual Conference, 2009
- [4] Too chuan tan, feng duan and tetsunari inamura, member, IEEE 2012; Adeena mignogna, "Multimodal human-robot interaction with chatterbot system: extending AIML towards supporting embodied interactions jeffrey simple aiml editor," available at: <http://riotsw.Com/sae.Html>, accessed on 20th january 2013.
- [5] N. Bush, (2013) program D, available at: http://aitools.Org/program_d, accessed on 30th january 2013.
- [6] Chun-Hung Lu^{1,2}, Guey-Fa Chiou², Min-Yuh Day, Chorng-Shyong Ong³, Wen-Lian Hsu, "Using Instant Messaging to Provide an Intelligent Learning Environment National Science" Council under GRANT NSC94-2752-E-001-001-PAE.
- [7] Bayan Abu Shawar and Eric Atwell, 2007 "Chatbots: Are they Really Useful?" LDV Forum - GLDV Journal for Computational Linguistics and Language Technology. In Proceedings of the IADIS International e-Commerce 2005 Conference, Porto, Portugal, December 15-17, pages 50–57. IADIS Press.
- [8] Kerly, A., Hall, P., and Bull, S. , "Bringing chatbots into education: Towards natural language negotiation of open learner models." Journal Knowledge-Based Systems [archiv](#) Volume 20 Issue 2, March 2007 Pages 177-185
- [9] Lane, H.C. " Intelligent Tutoring Systems: Prospects for Guided Practice and Efficient Learning. Whitepaper for the Army's Science of Learning Workshop, Hampton," VA. Aug 1-3, 2006. AliceBot (2013), AliceBot, Available at: <http://alicebot.blogspot.com.br>, Accessed on 30th Jan.13
- [10] E. A. Schegloff , "Conversation Analysis and Communication Disorders", In C. Goodwin (Ed.), Conversation and Brain Damage, pp. 21-55, Oxford: Oxford University Press 2003.
- [11] J. Weizenbaum (1966), "Eliza – a Computer Program for Study of Natural Communication Between Man and Machine", Communications of the Association for Computing Machinery, vol. 9, pp. 36-45.
- [12] P. Chatterjee, and A. Nath, "Massive Open Online Courses (MOOCs) in higher education – unleashing the potential in India," in 2014 IEEE Int. Conf. on MITE, pp. 256–260.
- [13] R. Wallace (2003), The Elements of AIML Style, ALICE A.I Foundation, 2001

BIOGRAPHIES



Rinkal Devendrabhai Dharani is a ME Student in the Electronics & Communication Department, College of L.J. Institute Engineering and Technology, Gujarat. She Appearing Master of Engineering (ME) degree in 2014- 2016 from L.J.I.E.T., India. Recently Published 1 research paper. rinkal.dharani@gmail.com



Dr. A.C. Suthar, He did BE(EC) & ME(EC) From Gujarat University and PhD from KSV University Gujarat. He had 17 year experience in the field of Academic and Industry. He published more than 20 Research paper and 21 Journal and Articles and 6 Books/Dissertation Thesis and also guided to 1 PhD Candidate and 15 PG Research scholars in area of interests in Image Processing, Signal Processing, Embedded System & VLSI Technology. Currently Working as a Director at L.J.I.E.T. Gujarat. sutharac@gmail.com