

A Prototype of Smart Wheelchair System for Disabilities

M.Rajagomathi¹, N.Madhavan², S.Saravanakumar³, S.John Mortin⁴

¹Assistant Professor, Dept.of Electrical and Electronics Engineering, Kamaraj College of Engineering and Technology, TamilNadu, India

²Student, Dept.of Electrical and Electronics Engineering, Kamaraj College of Engineering and Technology, TamilNadu, India

³Student, Dept.of Electrical and Electronics Engineering, Kamaraj College of Engineering and Technology, TamilNadu, India

⁴Student, Dept.of Electrical and Electronics Engineering, Kamaraj College of Engineering and Technology, TamilNadu, India

Abstract - While the needs of many individuals with disabilities can be satisfied with power wheelchairs, some members of the disabled community find it difficult or impossible to operate a standard power wheelchair. To accommodate this population, several researchers have used technologies originally developed for mobile robots to create "smart wheelchairs" that reduce the physical, perceptual, and cognitive skills necessary to operate a power wheelchair. Normally a power wheelchair contains lots of sensors and laptops for various applications. It leads to more cost on the system. In this project we propose a prototype of a smart wheelchair system with low cost and easy control mechanism using Bluetooth Serial Communication and Arduino UNO ATmega328.

Key Words: Disabilities, Smart wheelchair, Prototype, Bluetooth control, Arduino

1.INTRODUCTION

The most important purpose of wheelchair is to enable a disabled person to move around easier. Due to the technological growth is also made an effect on automation in all manual works. The automation also has a major role in the wheelchair system. For achieving the automation in the wheelchair movement control on various environments leads to use more number of sensors and Laptop and other highly advanced tools. This kind of automation has been achieved only when spending more amount of cost on the system. The highly automated wheelchair system is not easy to reach low level people.

1.1 Objective

The objective of this project is to develop a prototype of smart wheelchair system which shows it doesn't need the manual human interaction on the wheelchair (handling the wheelchair to move around). This prototype is mainly created for enable a disabled person to handle the wheelchair movement in easy manner.

1.3 Methodology

The control of the wheelchair is easily by the application of Bluetooth Module HC-05(ASCII, Serial code communication)and Arduino UNO interfaced with Relay controlled DC Motors. It enables a disabled person to move around by using a Bluetooth device (Mobiles, Bluetooth Watch etc.) to control the movement of the motor with low cost and easy to handle. This wheelchair system can be easily reached to all people.

2. LITERATURE SURVEY

Shunichi Nozawa, Toshiaki Maki, Mitsuharu Kojima, Shigeru Kanzaki, Kei Okada, Masayuki Inaba describes, controlling the motion direction of wheelchair by using the robot which is being like a human. The humanoid robot is interact with the user and it can be able to understand the gestures and actions made by the user by using the high level sensors and it is also having the ability to detect the obstacle and take a right path to cross it. The whole setup of the wheelchair is tends to high cost[1].

Sanghyun Park, Jinsul Kim and Yonggwon Won describes a newtype of wheelchair system especially for the uphill ride with the wheelchair. Normal type of wheelchair will fail to climb on the uphills. But their wheelchair can able to upclimb the hill by adjusting the seat balance using the tilt and gyro sensors.the motor control is also achieved by using the Zig-Bee sensors [2].

3. SYSTEM COMPONENTS

- **Power Supply:** The Power Source used for this project is Sealed Lead Acid Battery and the range of this battery is 12V, 7.2Ahr. The Power supply is given to the Arduino and Relay Board.
- **DC Motor:** The motor used in this project is DC Geared Motor. There are four motors used in this project in the range of 12V, 500mA each.

- Relay Board:** 8 channel relay board used in this project. The relay board is connected with the motors. The relay board just switches the motor on/off controlling the motion. The working range of this board is 12V, it is working in both AC and DC supply. The motor is connected to the common ports of the Relay board and the Normally open and Normally closed are connected one another with the same ports of other relays.
- Bluetooth Module HC-05:** It is the one of the type of Bluetooth SPP (Serial Port Protocol) module. It is used to passing the communication data between Bluetooth Device (e.g. Smartphone) to Arduino in the form of serial code(ASCII). Transmitter(TX) and Receiver(RX) Pin are also available in this device. It can send the data up to 2MB per second and the working frequency of the module is 2.4GHz.
- Arduino Uno ATmega328:** It is a microcontroller board. It has 6PWM input , 6 Analog inputs and Transmitter(TX) and Receiver (RX) Ports. The RX Port is connected with the TX pin of Bluetooth Module and the TX port is connected with the RX pin of HC-05 module for transmitting and receiving the communication data. We can store the programme in arduino which helps to send analog signals to relay board based on the serial code communication between Arduino and Bluetooth module. The recommended power supply for this Microcontroller is 5V.

4. BLOCK DIAGRAM

The below block diagram shows the total setup connection of the prototype of smart wheelchair system.

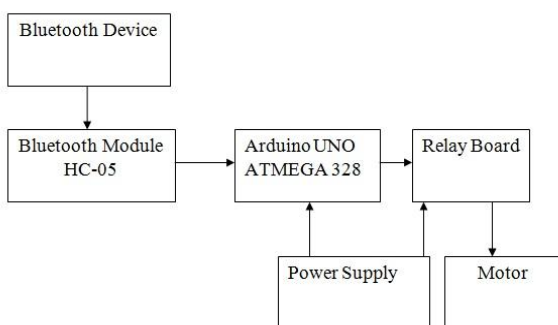

Figure 1.1 Block Diagram of the Proposed work

5. FLOW CHART

The below flow chart shows the working of the prototype of smart wheelchair system.

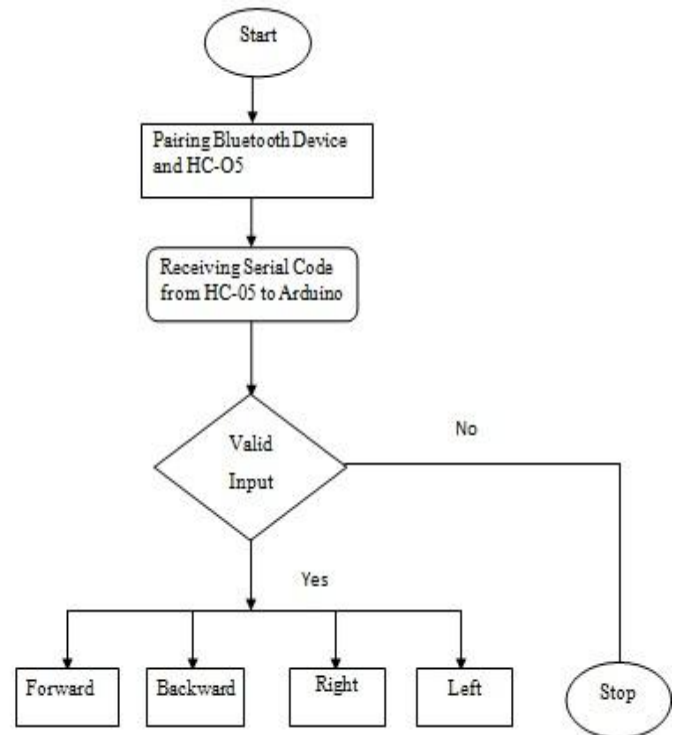

Figure 1.2: The Flow chart of the proposed work

6. EXPERIMENTS AND RESULTS

The prototype of the smart wheelchair system the wheelchair is shown in the figure 1.3

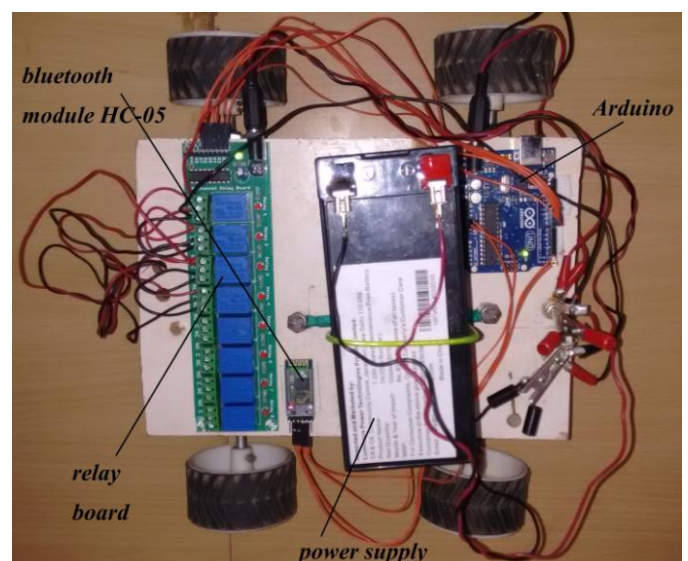

Figure 1.3 Prototype of Smart Wheelchair System

- When the power supply is on, the Arduino and Relay board is powered. It can notify by the glowing LED.
- The Bluetooth module HC-05 is paired with the Bluetooth device.
- The Bluetooth passes the signal in the form of Bluetooth wave. HC-05 receives the waves and convert the waves in the form of serial code (ASCII).
- In Arduino it receives the serial code and gives pulses with respect to the code to operate relay on/off.
- The operation of relay leads to control the motor movement in the direction forward, backward, left and right respectively.

Relay 1&3 ON-Wheelchair moves forward direction.

Relay 2&4 ON-Wheelchair moves backward direction.

Relay 2&3 ON- Wheelchair moves right direction.

Relay 1&4 ON- Wheelchair moves left direction.

All Relay in OFF - Wheelchair stops motion.

[3] N.H. Ismail, Zarina Tukiran, N.N. Shamsuddin " **Android-based Home Door Locks Application via Bluetooth for Disabled People**" 2014 IEEE International Conference on Control System, Computing and Engineering, 28 - 30 November 2014, Penang, Malaysia.

[4] Vigneshwar. Santhanam and Vignesh. Viswanathan " **Smartphone Accelerometer Controlled Automated Wheelchair**" 3rd International Conference on Electronics, Biomedical Engineering and its Applications (ICEBEA'2013) January 26-27, 2013 Hong Kong (China).

[5] Richard Simpson, PhD, ATP; Edmund LoPresti, PhD; Steve Hayashi, PhD; Illah Nourbakhsh, PhD; David Miller, PhD " **The Smart Wheelchair Component System**", JRRD Volume 41, Number 3B, Pages 429-442 May/June 2004 Journal of Rehabilitation Research & Development.

7. CONCLUSION

Thus the prototype of smart wheelchair is designed successfully. The motion of prototype is controlled using Bluetooth. If any Bluetooth device is available we can easily control the wheelchair using the Bluetooth.

8. FUTURE SCOPE OF THE PROJECT

- This prototype can be used to make the working model of the wheelchair.
- Additional features like horn, Light system can be added for using the wheelchair during insufficient sunlight or night times.
- This prototype only works with the android based Bluetooth. In future to make the system works with the Windows, iOS operating systems.

9. REFERENCE

[1] Shunichi Nozawa, Toshiaki Maki, Mitsuharu Kojima, Shigeru Kanzaki, Kei Okada, Masayuki Inaba " **Wheelchair Support by a Humanoid Through Integrating Environment Recognition, Whole-body Control and Human-Interface Behind the User**" 2008 IEEE/RSJ International Conference on Intelligent Robots and Systems Acropolis Convention Center Nice, France, Sept, 22-26, 2008

[2] Sanghyun Park, Jinsul Kim and Yonggwon Won " **An Efficient Electronic Wheelchair Seat Balancing Maintain Methodology Applying Smart Sensors**" International Journal of Smart Home Vol. 9, No. 1 (2015), pp. 81-92 <http://dx.doi.org/10.14257/ijsh.2015.9.1.09>