

Design and Implementation of Web based Vehicle Emission Monitoring and Notification System using ZigBee and GSM

Akash¹, S J Krishna Prasad²

¹ Student, Dept. of Telecommunication Engineering, MSRIT, VTU, Karnataka, India

² Associate Professor, Dept. of Telecommunication Engineering, MSRIT, VTU, Karnataka, India

Abstract – In present days, the proportion of air pollution caused by the cars is increasing rapidly. Many countries have already presented various methods of emissions standards to solve this serious problem like repairment of motor engine regularly or improve the quality of the gasoline etc. There are some situations which violates these emission standards. In this paper, a Wireless Inspection and Notification system (WINS) using the concept of ZigBee and GSM is proposed. By using this system we can smoothly monitor vehicles violating the emission standards. Radio frequency module (ZigBee) and GSM technology are mature wireless communication techniques adopted to collect and transmit emission information of vehicles.

Key Words: ZigBee, GSM, MQ 7 Sensor, MQ 5 Sensor, ppm, Log-Log graph, WINS System.

1. INTRODUCTION

Now a day, with the increasing of number of automobiles especially cars in metropolitan cities it is very difficult to solve the of air pollution problems caused by their exhaust gases. However; current methods doesn't seem to solve the emissions pollution problems. In this paper, we introduce Wireless Inspection and Notification System (WINS) developed to monitor the vehicle emissions. It real time monitors car's emissions in cities. The cars emissions information will be transferred and stored in backend system using ZigBee and GSM.

Then authorities can monitor which car fails to this test (i.e. exceed the standard emission levels) and give a

notice (message) to drivers and ask to repair their cars. ZigBee and GSM are low-cost reliable and mature wireless communication technologies employed in WINS system. They are mainly responsible for collecting and transmitting emissions information of vehicles from vehicle to central nodes (at poles) and central node to storage respectively.

2. WINS DESIGN

WINS stands for Wireless Inspection and Notification System. The whole system can be split into two sub-systems: (A) Inspection system (B) Notification system. In the real road situation, all data of vehicle emissions are firstly collected in the inspection system, with effect of adding some information such as time and vehicle identity. Then, these updated data will be transmitted to the storage system through the central nodes. Based on the local emissions standard, the notification system sends an alert message of repairing car to car owners along with their emission values.

2.1 Inspection system design

Inspection system can be further divided into Data collection and Data transmission.

(a) Data collection.

The Data Collection module is placed in car. The two sensors MQ-7 and MQ-5 sensors which senses the carbon-monoxide (CO) and Hydrocarbons (HC) respectively are placed near the vehicle exhaust. These sensors give emission values in analog signal in form of volts, which can be digitized using an inbuilt ADC in a microcontroller. From the Calculation

section discussed below, we can get both the values in ppm. These data along with some additional information such as time and vehicle id can be transmitted. A ZigBee transmitter module helps in transmitting to the central node.

(b) Data transmission.

The nodes is installed on pole in city center. This node consist of ZigBee receiver, a microcontroller and GSM module. We can deploy these nodes on many poles in city. Whenever the vehicle moves in range of the ZigBee of node, it receives the transmitted information from the vehicle. We can display the received information on the LCD display at node. The node acts as a communicating entity between the WINS system and the storage. Meanwhile the information can be transmitted to the storage system using GSM 3G Module. 3G data transmission is popular in comparison to other wireless communication technologies and is also inexpensive.

2.2 Notification system

This system receives the emission values from the node, stores in its database. It compares the emission values with the local emission standard. If the received vehicle emission exceeds the allowed figure, then it will send an alert message to the car owner to repair their cars as soon as possible. Meanwhile, the authorities also can check the car’s detail emissions information on a web page.

3. BLOCK DIAGRAMS

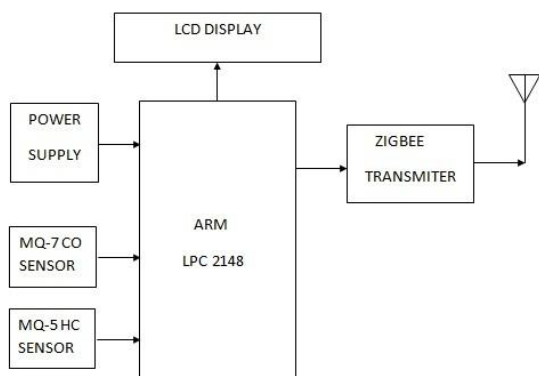

Fig -1: Block diagram of Data collection system (in car).

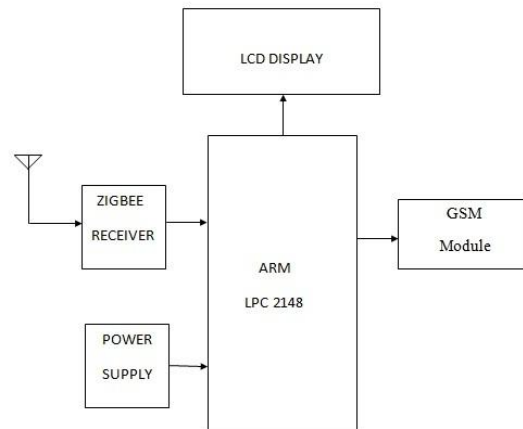

Fig -2: Block diagram of node (at pole)

4. SENSORS

4.1 MQ-7 SENSOR

They are used in detecting and measuring carbon monoxide (CO) in industries and cars.

4.2 MQ-5 SENSOR

They are used in detecting and measuring Hydrocarbons HC (such as methane, propane, butane etc.)



Fig -3: MQ Sensor

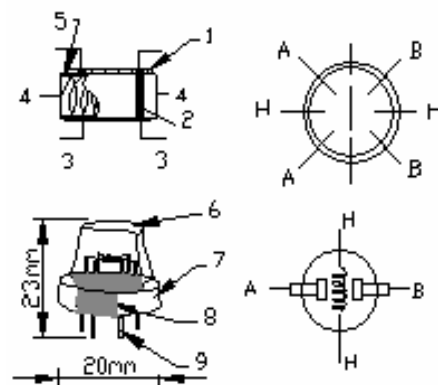

Fig -4: Structure and Configuration of MQ Sensor.

Structure and configuration, basic measuring circuit of MQ-5 and MQ-7 gas sensors is similar as shown in Fig -3 and Fig -4. They differ in concentration of Tin dioxide acting as a sensitive layer. Sensor composed by micro Al_2O_3 ceramic tube, Tin dioxide (SnO_2) sensitive layer, measuring electrodes and heater are fixed into a crust made by plastic and stainless steel net. The heater provides necessary work conditions for work of sensitive components. The enveloped MQ-7 and MQ-5 each has 6 pins, 4 of them are used to fetch signals, and other 2 are used for providing heating current.

5. EXPERIMENTS AND RESULTS

The concentration of gases is directly proportional to output voltage of sensors. The sensor gives an analog voltage varying from 0V to 5V depending upon concentration of gases. This analog voltage is given to the Analog to Digital converter to get in digital values denoted by V1.

After getting V1, the system will proceed with CO and HC concentration calculation. The value of CO concentration is obtained by calculating the value of the sensor resistance (R_s). The value of R_s is obtained from the following equation:

$$R_s = (5 - V1) / V1 \quad \text{----- (1)}$$

From the log-log graph shown in fig -5, the relationship between R_s and CO concentrations in ppm is obtained. Equation 2 shows the relationship between R_s and the CO concentration value. When x-axis equals zero, the intersection value between the graph linear line and the y-axis equals 100. Alpha (α) is the graph slope value.

$$C = 100 \times (R_s)^{1/\alpha} \text{ in ppm} \quad \text{----- (2)}$$

The slope value is obtained using the following equation

$$\alpha = (\log Y1 - \log Y2) / (\log X1 - \log X2) \quad \text{----- (3)}$$

By taking two points (first point at 100 ppm and second point at 1000 ppm) from the linear line graph, the slope can be calculated as

$$\alpha = (\log 100 - \log 1000) / (\log 1 - \log 0.1) \quad \text{----- (4)}$$

$$\alpha = -1$$

With the slope value equals -1, equation 2 can be simplified into

$$C = 100 / R_s \quad \text{----- (5)}$$

This equation (5) used to find the CO level in ppm.

Similarly for MQ-5 sensor, the curve shown in fig -6, meets the Y axis at $R_s/R_0 = 5$, and slope of the curve can be founded by eq. (3) which gives $\alpha = -0.3927$. The concentration of HC in ppm is given by

$$C = 5 / (R_s)^{2.52} \quad \text{----- (6)}$$

Conversion of ppm to percentage (%)

$$C (\%) = C (\text{ppm}) / 10000 \quad \text{----- (7)}$$

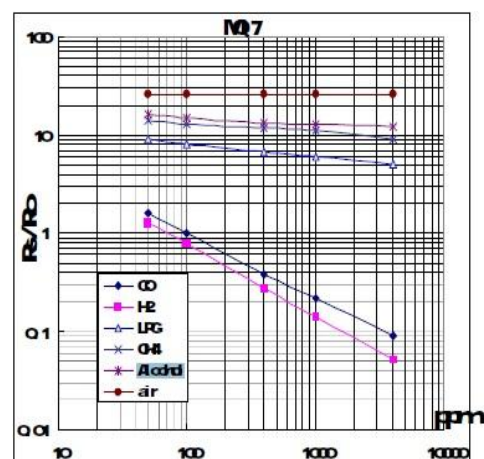

Fig -5: Graph Sensor resistance ratio (R_s/R_0) versus CO Concentration

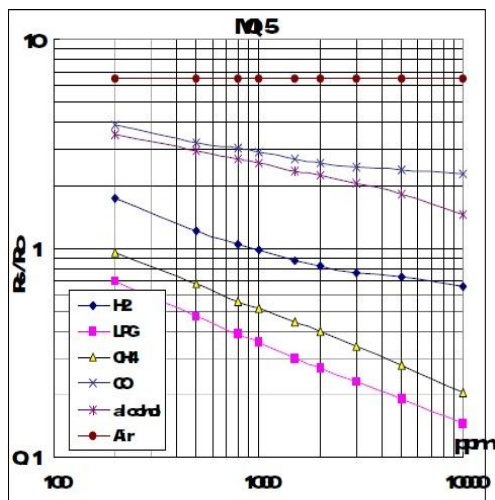

Fig -6: Graph Sensor resistance ratio (Rs/Ro) versus HC Concentration

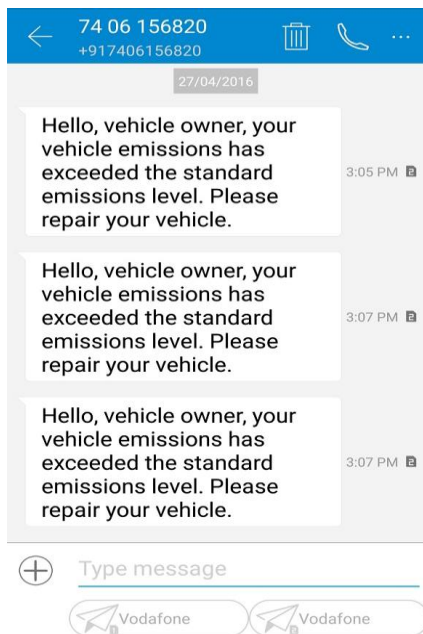

Fig -7: Screenshot of notification (alert) message.

7. CONCLUSIONS

WINS concept using the ZigBee and GSM can monitor vehicle emissions. The sensors give the CO and HC levels. With ZigBee pairs, the vehicle emission alert, and corresponding tag ID can be transmitted. The authorities can monitor vehicle emissions. The proposed system is an effective and reliable method for vehicle emissions inspection and by proper notification we can strictly reduce pollution levels in air.

REFERENCES

- [1] Chi-Man Vong and Pak-Kin Wong, "Application of RFID Technology and the Maximum Spanning Tree Algorithm for Solving Vehicle Emissions in Cities on Internet of Things," IEEE World Forum on Internet of Things (WF-IoT) 2014
- [2] A. J. McMichael, "The urban environment and health in a world of increasing globalization: Issues for developing countries." Bulletin of the world Health Organization, vol 78, pp. 1117-1126, 2000.
- [3] C. K. Chan and X. Yao, "Air pollution in mega cities in China," Atmospheric Environment, vol. 42, pp. 1-42, 2008.
- [4] J. H. Visser and R. E. Soltis, "Automotive exhaust gas sensing systems," IEEE Transactions on Instrumentation and Measurement, vol. 50, pp.1543-1550, Dec 2001.

BIOGRAPHIES



Akash B.E, (M.Tech)
Dept. of Telecommunication Engineering, MSRIT, VTU, Karnataka, India



S. J Krishna Prasad B.E, M.Tech, (Ph.D.)
Associate Professor, Dept. of Telecommunication Engineering, MSRIT, VTU, Karnataka, India
Research area: Optical sensors deployment in medical applications.