

# AVR Microcontroller Based Wearable Jacket for Women Safety

Daniel Clement<sup>1</sup>, Kush Trivedi<sup>2</sup>, Sabni Agarwal<sup>3</sup>

Shikha Singh<sup>4</sup>

<sup>1,2,3</sup>BTech Students, Department of Electrical and Electronics Engineering, Indus University, Gujarat, India

<sup>4</sup>Assistant Professor, Department Of Electrical and Electronics Engineering, Indus University, Gujarat, India

\*\*\*

**ABSTRACT**-In today's world, women safety has become a major social concern in the society.. This paper intends to presents a unified combination of wearable jacket and mobile technology for Safety of women in the society. This technique helps to alert family member and people closest to the victim by using GPS and GSM module, buzzer and LED Module. On activating the system, a GPS module captures the current location of the victim and sends an emergency alert message to the registered contact using GSM Module. The LED Modules and Buzzer are used to grab attention of nearby public and through attacker off-guard. The main advantage of this system is that the user does not require a smartphone unlike other application developed earlier and moreover the system considers response to time action gap which helps the victim to escape immediately.

**Keywords:**Women Safety, GSM, GPS, Alarm, LED, Buzzer

## 1. INTRODUCTION

The status of women in India has undergone many changes over past few decades. Since ancient time the history of Indian women has been eventful. Although, women have acquired top positions in job and society, yet they are facing unethical physical harassment and sexual assault. According to a global poll by Thomson Reuters, India is the 4<sup>th</sup> most dangerous country in the world for women and the worst country for women among G20 countries. Therefore, different types of security systems are designed for providing security to women in every aspect. This paper presents a unified combination of a wearable jacket at optimum results with the minimum hardware components and mobile technology, to help the victim in any kind of emergency situation.

### 1.1 Motivation

Women face much physical harassment on streets, public transport and parks, in and around schools and workplaces. It is found that most of these cases happen with women who are alone. Hence it becomes important to develop systems which help the women to fight even if she is alone. If a system could inform victim's family about her current location along with the people around

her, the chances of victim being helped are greatly improved. Such invention allows the victim to alert other people present in fixed radius along with family members. The Delhi Nirbhaya case that shocked the entire nation was the greatest motivation. It is high time that women needed a change.

### 1.2 Methodology

The proposed system is to design a portable device which resembles a normal jacket. It consists of AVR microcontroller, GSM/GPS modules, screaming alarm, LED modules and two switches. The prototype includes two independent system controlled using two switches. When first switch is pressed the device will get activated, immediately the location of the victim will be tracked with the help of GPS and emergency message along with latitude and longitude value will be sent to stored contacts every one minute with updated location. Simultaneously the LED module along with the screaming alarm unit will be activated. The LED module consists of high intensity leds connected in series that will let out a flash which will make the attacker lose his veering for few seconds, while the alarm will send out sirens to call out for help. When second switch is pressed the system will only send the location. The receiver will receive victim's updated location in form of coordinates which can be used to find exact location using GOOGLE MAPS.

## 2. DESIGN ARCHITECTURE

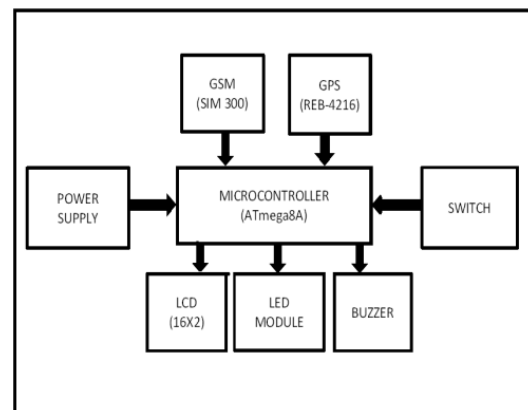

Fig-1:Block Diagram

The basic prototype of Women Safety Jacket is shown in

Fig.1. The project is powered by a 12V DC power supply, it consists of atmega8a microcontroller which is a 24 pin IC. The circuit consists of two switches which functions differently to give different output and activate the circuit. The circuits include GPS and GSM module, LCD, LED and buzzer. The GPS module is connected to the RX pin of the microcontroller through its TX pin and sends the location via the GSM module .The GSM module which is connected to the TX pin of the microcontroller through its RX pin. The output devices include the LCD, LED module and the buzzer .The LCD is used to show the longitude and latitude value which is not the part of end product. The two LED modules and the buzzer are used to grab attention of nearby people and throw the attacker off-guard. When switch one is pressed all these features i.e. the location of the victim, the LED modules and the buzzer start working simultaneously, and when switch two is pressed only the location of the victim is send to the emergency contacts.

## 2.1 Description of Transmission Unit

### 2.1.1. AVR (ATmega8A)

The ATmega8A belongs to AVR(enhanced RISC architecture) family with low power(5mW), high performance device as it works at crystal frequency of 16 MHz .It can execute powerful instructions in a single clock cycle (it achieves throughputs approaching 16MIPS per MHz) and In-System Self-Programmable Flash 8-bit microcontroller. The other features of ATmega8A include 1Kbyte SRAM and 512-byte EEPROM internal memories. It is as well recognized as the center of this system. This microcontroller works as an interfacing media between a GPS receiver and GSM module. The most important feature of this microcontroller includes the power saving modes: idle, power-down, and standby. The microcontroller initiates and sends the wearer’s information, message details to the mobile phone through the GSM chip placed in the GSM module .

### 2.1.2. GPS Technology

In order to determine speed, position, direction and time, GPS technology is used which is based on a global navigation satellite system. The GPS receiver gets activated by an accurate microwave signal which is transmitted by a constellation of 24/32 active satellites in Earth orbit. To calculate the distance and figure out its latitude and longitude dimensions, a GPS receiver needs at least three or four satellites .

### 2.1.3 GSM Technology

The SIM300A GSM modem used in the prototype, accepts the SIM card of any GSM network operator and which has its own unique mobile number .Through this GSM technology, which is a triband 900/1800/1900 MHz, we can develop embedded application of SMS based remote con-

trol and can set up communication for long distance transmission., for example, to send/receive SMS and make/receive voice calls.

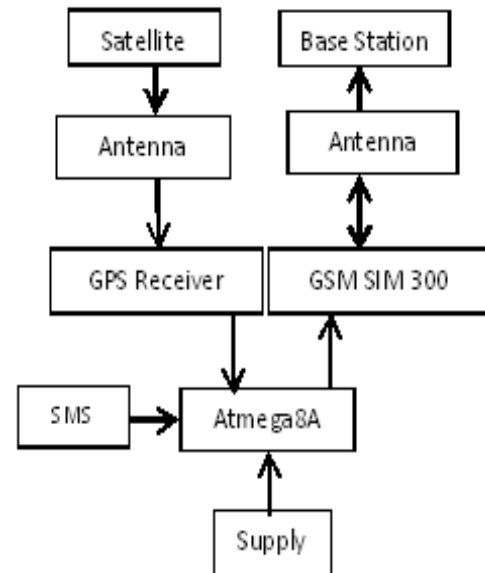

Fig-2:Architecture of transmission unit

## 2.2ReceptionUnit

An Android GSM mobile with a web based Android application supporting it makes the reception unit. The GSM mobile will receive an SMS which includes a “HELP” message and another SMS which includes location (longitude and latitude) of victim. By opening the SMS received in the mobile phone with an internet plan, we can search the exact location of the victim directly by using Google Map. The pointer pointing towards the location is the exact current location of the wearer. The others modules of reception unit includes LED Module and Piezo Buzzer.5630 type of Surface-Mounted-Device Light-Emitting Diode(SMT) has been used in the prototype.5630 describes the dimension of single SMD LED(56mm x 30mm).The module is a 44\*44 dimension module with 24 SMD LEDS connected in series with each other.

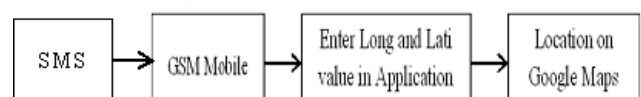

Fig-3:Reception Unit

## 3. HARDWARE DESCRIPTION

To locate the wearer and help her in case of need, the

prototype is designed which is a combination of hardware and software. The hardware unit consists of push-buttons S1 and S2 that has message sending capacity, alarm system, flash light, GPS and GSM module, Buzzer and LED Modules which are interfaced with ATmega8A controller for continuous monitoring, flashing and message sending from the device along with help siren.

### 3.1 Switching Unit

As shown in Figure 4, it consists of two switches which are used by device, that is, women safety jacket for sending SMS and activating alert systems like Buzzer and LED Modules. Two different operations are performed by each switch as follows:

S1: for continuously sending location(longitude and latitude) to the emergency numbers one after the other with delay of one minute. Along with that the switch is used for activating , screaming alarm and flash light.

S2: for continuously sending location to the emergency numbers.

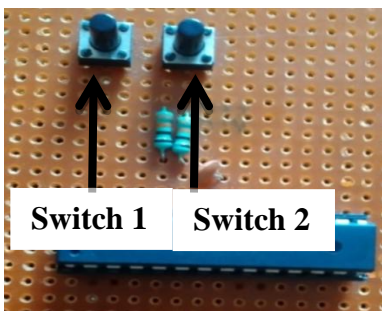

Fig-4:Switching Unit

### 3.2. GPS Module

Figure 5 illustrates GPS module which works on 5V supply. It continuously senses the current position of the wearer and sends it automatically to the microcontroller.



Fig-5:GPS Module

### 3.3.GSMModule

In Figure 6 GSM module is used for communication, that is, for sending SMS which contains the current location of the wearer leaving information.



Fig-6:GSM Module

### 3.4 LED Module

Figure 7 illustrates LED module which works on 12V supply. It continuously flashes light into attacker's eyes which causes the attacker to lose his veering.

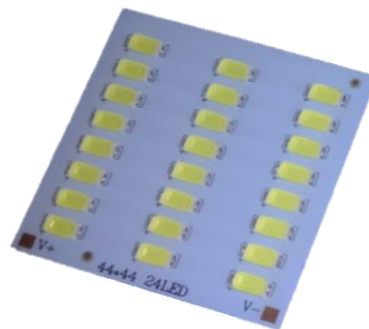

Fig-7:LED Module

### 3.5 Buzzer Module

Figure 8 illustrates buzzer Module which works on 12V supply. It continuously gives out siren which helps to grab attention of nearby public.



Fig-8: Buzzer

## 4. SOFTWARE DESCRIPTION

### 4.1 AVR Studio 4

For developing applications based on 8-bit AVR micro-

controller, AVR studio 4 which is an Integrated Development Environment (IDE) by ATMEL is used. This software is primarily utilized to activate AVR (ATmega8A) microcontroller according to the input received by it. By using this programming tool “Embedded C” code is written. In this project, coding is written for GPS, GSM, and switching unit for LED and Buzzer which are interfaced with microcontroller. The interfaced modules generate appropriate output according to the code embedded in the controller

### 4.2 Proteus

For computer-aided design, simulation and design of electronic circuits , a software package Proteus is used. This software is used to check the implemented hardware design. The software consist option of virtual terminal which helps to connect GSM and GPS module directly and check the GPS output continuously.

### 4.3. Design Methodology

Figure 9 describes the flowchart/ design methodology steps as follows.

Fig-9: Flow Chart

- (i) Wear the safety jacket.
- (ii) Then when an emergency situation occur the wearer

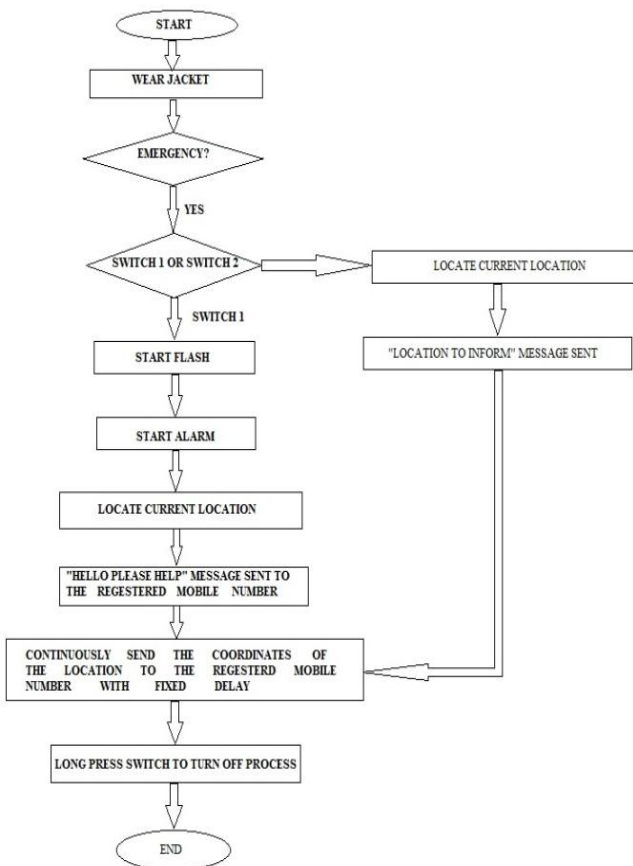

will have two options

- (a) Whether to activate the whole system, that is, sending location, activating screaming alarm and flash light
- (b) Whether to activate only location tracking and message sending
- (iii) When switch 1 is pressed, the device will continuously monitor the latest location of the wearer, generate an SMS alert, and will send it to registered contact continuously with delay of one minute. Simultaneously screaming alarm and LED Modules will be activated in order to grab attention of nearby public and to through attacker off-guard respectively.
- (iv) When switch 2 is pressed, the device will only continuously monitor the latest location of the wearer, generate an SMS alert, and will send it to registered contact continuously with delay of one minute.

## 5. RESULTS

### 5.1 Working

A model with GPS REB-4216, GSM SIM300, SMD LED Module, Buzzer controlled by Atmega8A microcontroller acts as the prototype jacket (Fig 10).

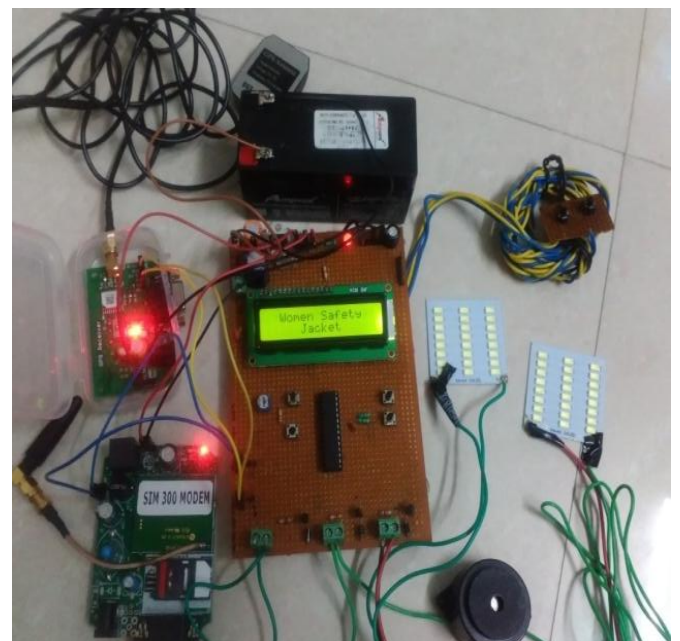

Fig-10:Prototype Jacket

NMEA Latitude and Longitude data being received and is shown in LCD(Fig 11), below is the image of the system when switch 1 is pressed(Fig 12) and the GSM message received by the emergency contacts(Fig 13)



Fig-11: LCD Showing Lati& Long value

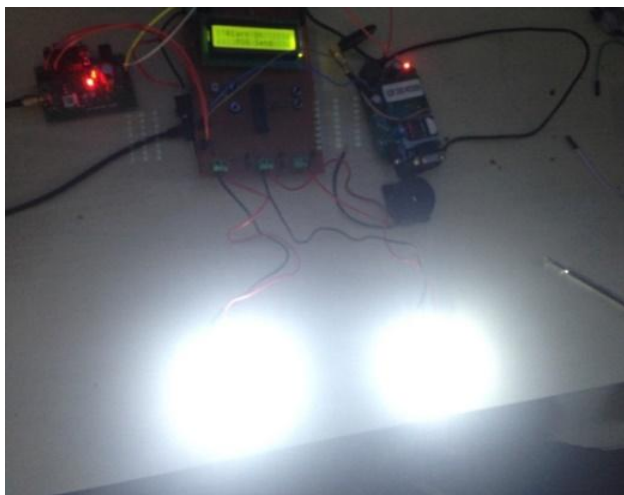

Fig-12: LED and Buzzer On

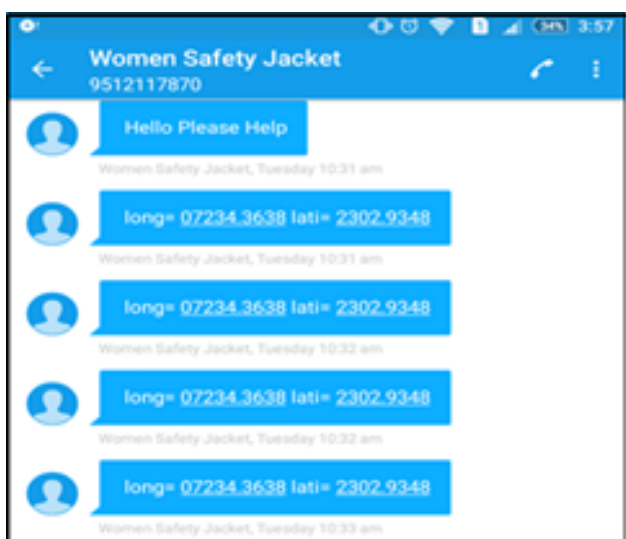

Fig-13: Messages on receiver Mobile when switch1 is pressed

Figure below shows the messages send to the stored contact when switch 2 is pressed (Fig14) and the location on Google maps when received longitude and latitude values are entered (Fig 15).

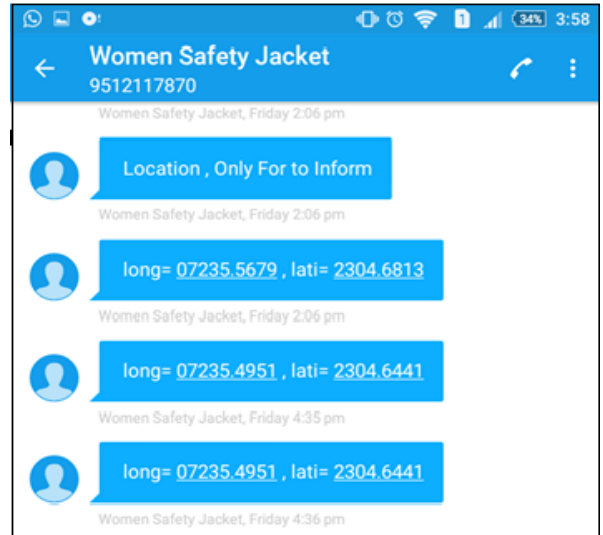

Fig-14: Messages when switch2 is pressed

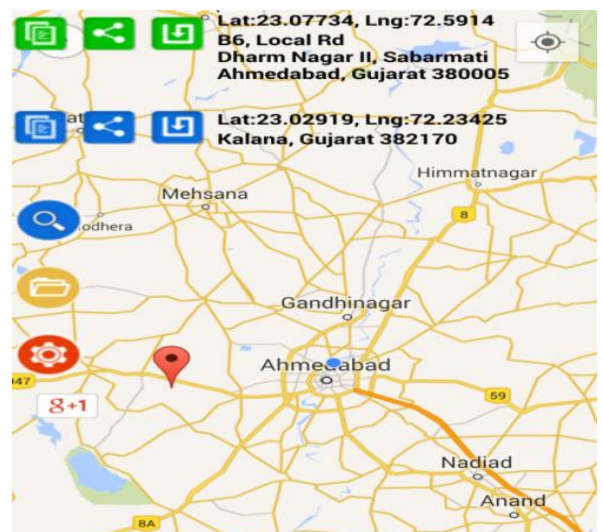

Fig-15: Location on Google Maps

### 5.2 Power Consumption Details

Table-1: Power consumption table

Sr no.	Components	Voltage	Current	Power
1.	Buzzer	12V	15mA	180mW
2.	LED Modules	12V	40mA X 2	480mW X 2
3.	GSM	5V	60mA	300mW

4.	GPS	5V	85mA	425mW
5.	LCD	5V	20mA	100mW
6.	Microcontroller	5V	8mA	40mW
7.	Other Components	5V	7mA	35mW
8.	Total(Working)	12V	250mA	3W
9.	Total(Stand By)	12V	140mA	1.68W

## 6. CONCLUSION AND FUTURE SCOPE

### 6.1 Conclusion

This paper has mainly focused on safety of women in public places. The different modules used in the system are combined to develop women safety Jacket. This system makes use of GSM and GPS module which is used to send emergency message along with current longitude and latitude value to stored contacts. On detecting violence situation, the system may be activated by simply pressing a switch. On pressing switch 1, the system will activate GSM and GPS modules along with flash lights and Buzzer which will cause the attacker to lose his veering and help to call nearby public. However in a situation where the victim just want to send the location, she can easily do that by pressing switch2 which will only activate GSM and GPS module keeping the other two output devices off. The project has been developed with such a motivation that it will leave no stone unturned to provide women with safe environment under all the circumstances. As the system is fabricated into a jacket, no one would be able to evaluate whether it is a safety jacket or just a regular jacket.

### 6.2 Advantages

- This system can overcome the fear that scares every woman about her safety and security.
- Cost effective as it is controller based.
- Low power consumption.
- Small in size.
- Different modules used for security purpose are easily available and are not so expensive
- Even if the GSM and GPS system does not catch the network the other two modules i.e. LED module and buzzer will still help the victim to rescue.

### 6.3 Limitations

- GPS and GSM reliability: The GPS and GSM system are not reliable. These modules suffers problems during overcast, also the GPS is unable to initialize

quickly when kept under extreme indoors. However if the GPS system locate the location sometimes the GSM module does not have coverage and hence the messages are not sent to the stored contacts.

- Battery consumption and weight: The modules used in the system needs 12V supply which makes the battery heavy also we required high mAh battery to keep system working for longer time. This can be avoided simply by using LiPo battery which solves the weight problem but increases cost of system.
- Mobile Network: The system sends emergency message to stored contacts but however it would not be helpful if the receiver mobile is out of coverage area.

### 6.4 Future Scope and Applications

This paper has mainly focused on one of the alarming issue in the society i.e. security and safety of women in India. In this paper, we have showed a prototype using different modules. Testing of system shows that the system worked efficiently. The system is of low cost and thus very effective and productive. However there is always a scope of improvement. As the technology changes or new requirement from the user to enhance the functionality of product vary, it may require to introduce new version with additional modules without any major changes to the entire system. With further research and innovation, this system can be implemented in different forms. The system can be used in form of different wearable devices. This system can be implemented as safety locator wrist band using GSM and GPS modules, as a safety belt etc. We can also prepare an android application which directly shows the location on obtaining the longitude and latitude values. We can also include small camera which will capture the image of the attacker and help the victim.

### REFERENCES

- [1] Thooyavan V, "Advanced Security System For Women", Department Of ECE Vidya Vikas College Of Engineering And Technology Vasai Thane India, Final Year Project, Serial Number Hem 128 IEEE 2014 Project List Under Real Time Target Surveillance System, Slides Share On [www.slideshare.net](http://www.slideshare.net), Jun 24, 2014.
- [2] Prof. Basavaraj Chougula, Archana Naik, Monika Monu, Priya Patil And Priyanka Das "Smart Girls Security System", Department Of Electronics And Telecommunication KLE'S College Of Engineering And Technology Belgaum India, ISSN 2319 – 4847 International Journal Of Application Or Innovation In Engineering & Management (IJAEM) Web Site: [www.ijaem.org](http://www.ijaem.org), Volume 3, Issue 4, April 2014.
- [3] Nishant Bhardwaj And Nitish Aggarwal, "Design And Development Of "Suraksha"-A Women Safety Device", Department Of Electronics And Communica-

tion ITM University Huda Sector 23-A Gurgaon Delhi India, ISSN 0974-2239 International Journal Of Information & Computation Technology Online Available at <http://www.irphouse.com>, Volume 4, PP. 787-792, November 2014.

- [4] "Using wearable technology to answer women's safety" by TumanPoddar, Ritesh C, NagarajaBharath Department Of Telecommunication Engineering, Cmr Institute Of Technology, International Journal of Science, Technology & Management Volume No.04, Issue No. 05, May 2015
- [5] <http://www.engineersgarage.com/tutorials/at-commands>
- [6] <http://quxin.manufacturer.globalsources.com/si/6008824501152/pdtl/Piezoelectric-ceramic/1131416316/low-current-22mm-6V-12V-24V-DC-piezo-buzzer-wired.htm>
- [7] <http://www.botskool.com/user-pages/tutorials/electronics/simple-8-bit-16x2-lcd-interfacing-pic-16f>
- [8] <http://www.firmcodes.com/microcontrollers/8051-3/interfacing-lcd-with-8051/lcd-commands-and-understanding-of-lcd/>
- [9] <http://www.engineersgarage.com/insight/how-piezo-buzzer-works>
- [10] <http://www.tenettech.com/product/2442/16-x-2-character-lcd-display-with-backlight-jhd162a-green#contentHome-tab>
- [11] <http://www.datasheetspdf.com/datasheet/JHD162A.html>
- [12] <http://www.dfrobot.com/image/data/FIT0127/datasheet.pdf>
- [13] <http://www.engineersgarage.com/tutorials/at-commands>
- [14] <http://www.engineersgarage.com/contribution/how-to-interface-GSM-SIM-300-modem-with-atmega32-to-send-and-receive-SMS>