

## DESIGN AND MANUFACTURING OF ACRYLIC JIG

Mujaffar Momin<sup>1</sup>, Sanket Lokhande<sup>2</sup>, Pradip Gunavant<sup>3</sup>, Narendra Kokil<sup>4</sup>

<sup>1</sup>BE Scholar, Mechanical, DACOE, Karad, Maharashtra, India

<sup>2</sup> BE Scholar, Mechanical, DACOE, Karad, Maharashtra, India

<sup>3</sup> Assistant Professor, Mechanical, DACOE, Karad, Maharashtra, India

<sup>4</sup>Sr.Manager Mfg. Engineering at KEPL, Kirloskarwadi, Maharashtra, India

\*\*\*

**Abstract** - Jig is a special device that holds, supports, or is placed on a part to be machined. It is a production tool made so that it not only locates and holds the work piece but also guides the cutting tool as the operation is performed. Jigs are usually fitted with hardened steel bushings for guiding drills or other cutting tools. A jig is designed and built to hold, support and locate every component (part) to ensure that each part that is drilled or machined within the specified limits. The correct relationship and alignment between the tool and the work piece is maintained. We studied the problems which were occurring during drilling operations in "Kirloskar Ebara Pumps Limited Kirloskar Wadi". We find that we will make design and manufacture of acyclic jig so as to overcome the problem occurring when manual marking is performed. Also due to Acrylic jig the cost of jig manufacturing is reduced. Jig is designed as per job requirements. In this study we use acrylic material for jig manufacturing. Also for reducing production cycle time we implemented combination of two PCD (Pitch Circle Diameter) on single jig.

**Key Words:** Design and Manufacturing of jig, Acrylic material, Common Modular of Acrylic Jig, Guide Ring, Bush.

### 1. INTRODUCTION

Over the past decades, manufacturing has made considerable progress. Different new machine tools, High-performance cutting tools and modern manufacturing processes are used in today's modern industries to make parts faster and better than ever before. Mass production has a demand of fast and easy method of positioning work for accurate operations on it. Jigs are production tools used to manufacture duplicate and interchangeable parts. Jigs are specially designed so that the large numbers of components can be machined identically, and to ensure interchangeability of components. The most common jigs are for drilling and boring operation and they differ as per size, type, and placement of drill bushes.

### 2 LITERATURE REVIEW

J. C. Trappey [1] in this paper author made the study of research done on jigs and fixture 1980s. They did study of different principle used for design of jigs and fixtures. The major principle includes supporting, locating and clamping automated fixtures design.

Taufik, R.S.[2] This paper shows study made in design of jigs and fixtures for hydraulic press machine in manufacturing company. The problems were occurring at industry. It is facing the utilization of hydraulic press machine. When the demand has increased it occurs on the gripping or holding the work piece tightly. The main objective is to give a new design of jigs and fixtures for hydraulic press so as to carry out the gripping problem from existing design. Several new design concepts were given and analyze using ANSYS software. The design parameters were presented are maximum deformation, maximum shear stress, number of contact faces, and maximum holding force. Based on the analysis result, the improvement of new jigs and fixtures design for hydraulic press machine was done.

Sawita D. Dongre[3] This paper is about the design and analysis of Jigs and fixture which is used in the manufacturing of chassis bracket of Bajaj car RE60 (passenger car). The main purpose of the jigs is to provide strength, holding, accuracy and interchange ability in the manufacturing of the product. So in this paper study on design of jigs and fixtures while manufacturing of chassis bracket. Also the analyzing stress and strain developed in jigs and fixtures and chassis bracket is done.

NBV Lakshmi Kumari[4] This paper is about Design and Analysis of Indexing Type of Drill Jig for a component having angular holes at 25 deg such the design is validated and verified. For indexing, the mechanism adopted is Spring and Plunger arrangement. Hence in this paper main focused was to design jig for hole which are in a specific angle.

In all paper above the focused was not given on the material used for manufacturing of jigs. Also the focus was not give on making the jig modular i.e. making combinations of two PCDs. We have given focused on this point in this project and manufactured modular jig with Acrylic material.

## 2. PROBLEM IDENTIFICATION

In **M/S KIRLOSKAR EBARA PUMPS LTD** at some pump components drilling operation is performed by manual marking. Hence manual error occurs in marking for drilling operation. Also we observed that production cycle time is maximum.

**Due To Above Conditions Following Problem Occurs:**

- Error observed in pcd of component at drilling operation.
- Spacing between equi-spaced holes is not maintained.
- A problem occurs in assembly of such components.
- Rework and rectification is required for such components.
- Production idle time is increased.
- Production cost increased.
- CDD (Contractual Delivery Date) is not maintained.

## 3 PROBLEM SOLUTIONS

- ❖ Decided To Design And Manufacture Jigs By Using ACRYLIC Material.
- ❖ Decided To Manufacturing of Common Modular Acrylic Jigs i.e. two PCD on a single jig.

### 3.1 Why Acrylic Material?

- Excellent mechanical machining.
- Lightness and toughness.
- Dimensional stability.
- Strength.
- Heat resistance.
- Availability.
- Safety.
- Weather resistance.
- Colour verity.

### 3.2 Common Modular Acrylic Jigs

As per the traditional method mild steel and cast iron material were used for manufacturing of jigs. This jig is difficult for handling for the workers. Also the cost of manufacturing of this metallic jig is more

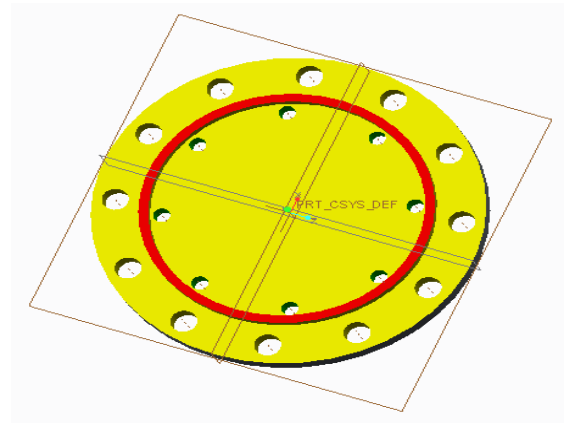

**Fig 3.2.1:** Traditional jig

The above fig shows the traditional jig which has single PCD. Also the metallic step which takes the guide with the job while drilling operation.

### ❖ NEW ACRYLIC JIG DESIGN

New Acrylic jig design made in software PRO-E version creo options modeler 2.0



**Fig 3.2.2:** 1<sup>st</sup> face of Acrylic jig

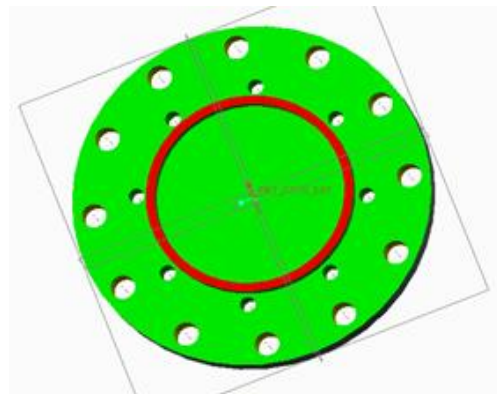

**Fig 3.2.3:** 2<sup>nd</sup> face of Acrylic jig

### 3.3 MANUFACTURING

Following photographs shows the manufacturing of Acrylic jig. Jig was manufactured at in house of Kirloskar Ebara Pumps Ltd.



Fig 3.3.1: Machining of acrylic plate



Fig 3.3.2: Drill Bushes



Fig 3.3.4: Assembly of Jig Plate



Fig3.3.5: Inspection of Acrylic on CMM (Co-ordinate Measuring Machine)



Fig 3.3.3: Guide Rings



Fig 3.3.6: While doing inspection of acrylic jig



#### 4. CONCLUSIONS

❖ We design and developed the Acrylic jig with the help of Acrylic material. Also we made the Common Modular Acrylic Jigs i.e. two PCD on a single jig.

- ✓ We Eliminate the Error observed in pcd of component at drilling operation
- ✓ Spacing between equi-spaced holes is maintained.
- ✓ Production idle time is reduced.
- ✓ CDD (contractual delivery date) is maintained.
- ✓ Due to Acrylic material jig manufacturing cost is reduced.

#### ❖ FUTURE SCOPE

- The design can be made more modular i.e. more pcd combination can be done.
- Instead of Acrylic Plastic and other material can be used.
- We can fix bush size and interchange the liner size according to the drill size.

#### REFERENCES

- [1] Trappey, J. C. and C. R. Liu, (1990): A LITERATURE SURVEY OF FIXTURE DESIGN AUTOMATION, Int J Adv Manuf Technol 5. (240-255)
- [2] Taufik, R.S.; Hirmanto, S.; Sivarao, Hambali, A. and Tajul, A. A., (2012): Design of Jigs and Fixtures for Hydraulic Press Machine” Malikussaleh Industrial Engineering Journal Vo.1 No.1 (19-24) ISSN 2301 934X.
- [3] NBV Lakshmi Kumari, G.Prsasna Kumar IOSR Journal of Mechanical and Civil Engineering (IOSR-JMCE) e-ISSN: 2278-1684,p-ISSN: 2320-334X, Volume 12, Issue 2 Ver. I (Mar - Apr. 2015), PP 46-51
- [4] BS 1098 PT.2 1977/ISO 4247/DIN 172A
- [5] LittleMachineShop.com (800) 981-9663
- [6] P.H.Joshi, “Jigs And Fixtures”, 3rd Edition from Tata McGraw Hill company Ltd.
- [7] A Reference Course Material by Foundry & Forge training Centre, Pune , on “Design Of Jigs & Fixtures” April 2011,pp50-52.
- [8] International journal of scientific & Engineering Reasearch , volume 5 , Issue 2, feb 2014 ISSN 2229-5518

#### BIOGRAPHIES



“Mr. Mujaffar Babaji Momin. Pursuing B.E. mechanical at Dr. Daulatrao Aher College Of Engineering , Karad , from Shivaji University , Kolhapur.(2016)”



“Mr. Sanket Gajanan Lokhande. Pursuing B.E. mechanical at Dr. Daulatrao Aher College Of Engineering , Karad , from Shivaji University , Kolhapur.(2016)”



“Mr. Pradip S. Gunavant ME Mechanical Assistant Professor at Dr. Daulatrao Aher College Of Engineering, Karad, Maharashtra.”