

An Improved UPQC Controller to Provide Additional Grid Voltage Regulation as a STATCOM

P.Ananda sundaravalli¹, S. Arumugam²

¹PG Scholar, Department of EEE, Sri Shakthi college of Engineering and Technology, Tamil Nadu, Indian

²Assistant Professor, Department of EEE, Sri Shakthi of engineering and Technology, Tamil Nadu, Indian

Abstract - This paper presents an improved controller for the dual topology of the unified power quality conditioner (IUPQC) extending its applicability in power-quality compensation, as well as in microgrid applications. By using this controller, beyond the conventional UPQC power quality features, including voltage sag/swell compensation, the IUPQC will also provide reactive power support to regulate not only the load-bus voltage but also the voltage at the grid-side bus. In other words, the IUPQC will work as a static synchronous compensator (STATCOM) at the grid side, while providing also the conventional UPQC compensations at the load or microgrid side. Simulation results are provided to verify the new functionality of the equipment.

Keywords : IUPQC, Microgrids, power quality, Static Synchronous Compensator(STATCOM), Unified Power Quality Conditioner(UPQC).

1.INTRODUCTION

Power-electronics devices have brought about great technological improvements. However, the increasing number of power-electronics-driven loads used generally in the industry has brought about uncommon power quality problems. In contrast, power-electronics driven loads generally require ideal sinusoidal supply voltage in order to function properly, whereas they are the most responsible ones for abnormal harmonic currents level in the distribution system. In this scenario, devices that can mitigate these drawbacks have been developed over the years.

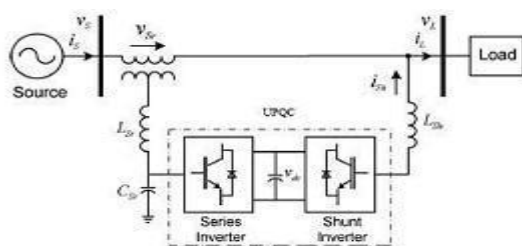

Fig. 1. System configuration of UPQC.

Some of the solutions involve a flexible compensator, known as the unified power quality

conditioner (UPQC) and the static synchronous compensator (STATCOM). The power circuit of a UPQC consists of a combination of a shunt active filter and a series active filter connected in a back-to-back configuration. This combination allows the simultaneous compensation of the load current and the supply voltage, so that the compensated current drawn from the grid and the compensated supply voltage delivered to the load are kept balanced and sinusoidal. The dual topology of the UPQC, where the shunt active filter behaves as an ac-voltage source and the series one as an ac-current source, both at the fundamental frequency. This is a key point to better design the control gains, as well as to optimize the LCL filter of the power converters, which allows improving significantly the overall performance of the Compensator.

The STATCOM has been used widely in transmission networks to regulate the voltage by means of dynamic reactive power compensation. Nowadays, the STATCOM is largely used for voltage regulation, whereas the UPQC and the IUPQC have been selected as solution for more specific applications. Moreover, these last ones are used only in particular cases, where their relatively high costs are justified by the power quality improvement it can provide, which would be unfeasible by using conventional solutions. By joining the extra functionality like a STATCOM in the IUPQC device, a wider scenario of applications can be reached, particularly in case of distributed generation in smart grids and as the coupling device in grid-tied microgrids. The performance of the IUPQC and the UPQC was compared when working as UPQCs. The main difference between these compensators is the sort of source emulated by the series and shunt power converters. In the UPQC approach, the series converter is controlled as a non sinusoidal voltage source and the shunt one as a non sinusoidal current source. Hence, in real time, the UPQC controller has to determine and synthesize accurately the harmonic voltage and current to be compensated. On the other hand, in the IUPQC approach, the series converter behaves as a controlled sinusoidal current source and the shunt converter as a controlled sinusoidal voltage source. This means that it is not necessary to determine the harmonic voltage and current to be compensated, since the harmonic voltages appear naturally across the series current

source and the harmonic currents flow naturally into the shunt voltage source.

In actual power converters, as the switching frequency increases, the power rate capability is reduced. Therefore, the IUPQC offers better solutions if compared with the UPQC in case of high-power applications, since the IUPQC compensating references are pure sinusoidal waveforms at the fundamental frequency. Moreover, the UPQC has higher switching losses due to its higher switching frequency.

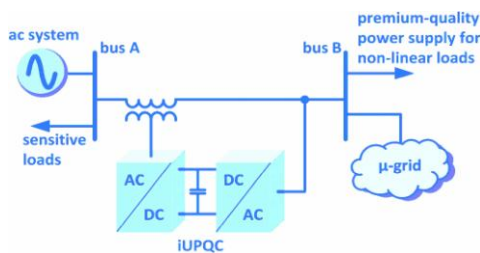

Fig. 2. Example of applicability of iUPQC.

This project proposes an improved controller, which expands the IUPQC functionalities. This improved version of IUPQC controller includes all functionalities of those previous ones, including the voltage regulation at the load-side bus, and now providing also voltage regulation at the grid-side bus, like a STATCOM to the grid. Simulation results are provided to validate the new controller design.

1.1 Modified IUPQC

In order to clarify the applicability of the improved iUPQC controller, below Fig depicts an electrical system with two buses in spotlight, i.e., bus A and bus B. Bus A is a critical bus of the power system that supplies sensitive loads and serves as point of coupling of a microgrid. Bus B is a bus of the microgrid, where nonlinear loads are connected, which requires premium-quality power supply. The voltages at buses A and B must be regulated, in order to properly supply the sensitive loads and the nonlinear loads. The effects caused by the harmonic currents drawn by the nonlinear loads should be mitigated, avoiding harmonic voltage propagation to bus A.

The use of a STATCOM to guarantee the voltage regulation at bus A is not enough because the harmonic currents drawn by the nonlinear loads are not mitigated. On the other hand, a UPQC or an iUPQC between bus A and bus B can compensate the harmonic currents of the nonlinear loads and compensate the voltage at bus B, in terms of voltage harmonics, unbalance, and sag/swell. Nevertheless, this is still not enough to guarantee the voltage regulation at bus A. Hence, to achieve all the desired goals, a STATCOM at bus A and a UPQC (or an iUPQC) between buses A and B should be employed. However, the costs of this solution would be unreasonably high.

An attractive solution would be the use of a modified iUPQC controller to provide also reactive power

support to bus A. Note that the modified iUPQC serves as an intertie between buses A and B. Moreover, the Microgrid connected to the bus B could be a complex system comprising distributed generation, energy management system, and

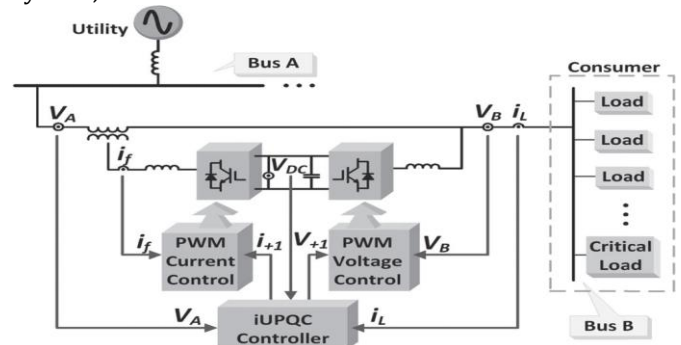

Fig. 3. Modified IUPQC Configuration

other control systems involving microgrid, as well as smart grid concepts. In summary, the modified iUPQC can provide the following functionalities:

- "Smart" circuit breaker as an intertie between the grid and the microgrid;
- Energy and power flow control between the grid and the microgrid (imposed by a tertiary control layer for the microgrid);
- Reactive power support at bus A of the power system;
- voltage/frequency support at bus B of the microgrid;
- Harmonic voltage and current isolation between bus A and bus B (simultaneous grid-voltage and load-current active filtering capability);
- Voltage and current imbalance compensation.

The functionalities (d)-(f) previously listed were extensively explained and verified through simulations and experimental analysis [14]-[18], whereas the functionality (c) comprises the original contribution of the present work. Fig. 3 depicts, in detail, the connections and measurements of the iUPQC between bus A and bus B. According to the conventional iUPQC controller, the shunt converter imposes a controlled sinusoidal voltage at bus B, which corresponds to the aforementioned functionality (d). As a result, the shunt converter has no further degree of freedom in terms of compensating active- or reactive-power variables to expand its functionality. On the other hand, the series converter of a conventional iUPQC uses only an active-power control variable p , in order to synthesize a fundamental sinusoidal current drawn from bus A, corresponding to the active power demanded by bus B. If the dc link of the iUPQC has no large energy storage system or even no energy source, the control variable p also serves as an additional active-power reference to the series converter to keep the energy inside the dc link of the iUPQC balanced. In this case, the losses in the iUPQC and the active power supplied by the shunt converter must be quickly compensated in the form of an additional active

power injected by the series converter into the bus B. The iUPQC can serve as: a) "smart" circuit breaker and as b) power flow controller between the grid and the microgrid only if the compensating active- and reactive-power references

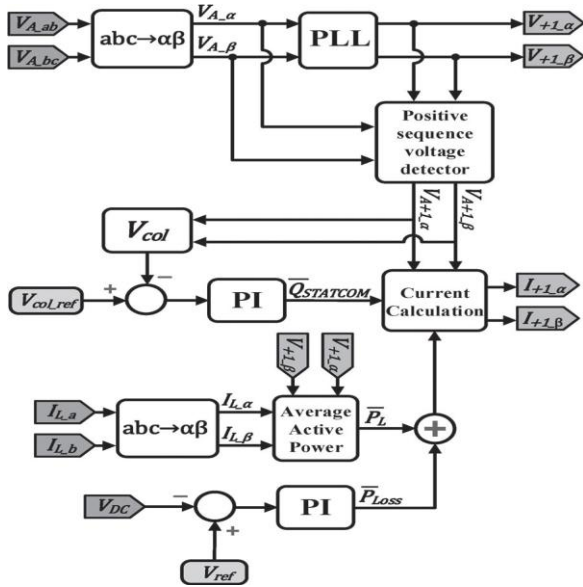

Fig. 4. Novel IUPQC Configuration.

of the series converter can be set arbitrarily. In this case, it is necessary to provide an energy source (or large energy storage) associated to the dc link of the iUPQC.

The last degree of freedom is represented by a reactive-power control variable q for the series converter of the iUPQC. In this way, the iUPQC will provide reactive-power compensation like a STATCOM to the bus A of the grid. As it will be confirmed, this functionality can be added into the controller without degrading all other functionalities of the iUPQC.

1.2 IMPROVED IUPQC CONTROLLER

A. Main Controller

Fig. 3 depicts the iUPQC hardware and the measured units of a three-phase three-wire system that are used in the controller. Fig. 4 shows the proposed controller. The controller inputs are the voltages at buses A and B, the current demanded by bus B (i_L), and the voltage v_{DC} of the common dc link. The outputs are the shunt-voltage reference and the series-current reference to the pulse width modulation (PWM) controllers. The voltage and current PWM controllers can be as simple as those employed, or be improved further to better deal with voltage and current imbalance and harmonics. First, the simplified Clark transformation is applied to the measured variables. As example of this transformation, the grid voltage in the $\alpha\beta$ -reference frame.

The shunt converter imposes the voltage at bus B. Thus, it is necessary to synthesize sinusoidal voltages with nominal amplitude and frequency. In the original iUPQC approach as presented, the shunt-converter voltage reference can be either the PLL outputs or the fundamental positive sequence component V_{A+1} of the grid voltage (bus A in Fig.3). The use of V_{A+1} in the controller is useful to minimize the circulating power through the series and shunt converters, under normal operation, while the amplitude of the grid voltage is within an acceptable range of magnitude. However, this is not the case here, in the modified iUPQC controller, since now the grid voltage will be also regulated by the modified iUPQC. In other words, both buses will be regulated independently to track their reference values. The series converter synthesizes the current drawn from the grid bus (bus A). In the original approach of iUPQC, this current is calculated through the average active power required by the loads P_L plus the power P_{Loss} . The load active power can be estimated by

$$P_L = V_{+1_α} \cdot i_{L_α} + V_{+1_β} \cdot i_{L_β}$$

Where $i_{L_α}$, $i_{L_β}$ are the load currents, and $V_{+1_α}$, $V_{+1_β}$ are the voltage references for the shunt converter. A low-pass filter is used to obtain the average active power (P_L). The losses in the power converters and the circulating power to provide energy balance inside the iUPQC are calculated indirectly from the measurement of the dc-link voltage. In other words, the power signal P_{Loss} is determined by a proportional- integral (PI) controller, by comparing the measured dc voltage V_{DC} with its reference value. The additional control loop to provide voltage regulation like a STATCOM at the grid bus is represented by the control signal $Q_{STATCOM}$. This control signal is obtained through a PI controller, in which the input variable is the error between the reference value and the actual aggregate voltage of the grid bus, given by

$$V_{col} = \sqrt{V_{A+1_α}^2 + V_{A+1_β}^2}$$

B. Power Flow in Steady State

The following procedure, based on the average power flow, is useful for estimating the power ratings of the iUPQC converters. For combined series-shunt power conditioners, such as the UPQC and the iUPQC, only the voltage sag/swell disturbance and the power factor (PF) compensation of the load produce a circulating average power through the power conditioners.

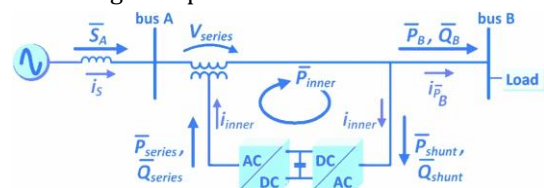

Fig. 5. IUPQC power flow in Steady state.

According to Fig. 5, the compensation of a voltage sag/swell disturbance at bus B causes a positive sequence voltage at the coupling transformer ($V_{series} = 0$), since $V_A = V_B$. Moreover, V_{series} and i_{PB} in the coupling transformer leads to a circulating active power P_{inner} in the iUPQC. Additionally, the compensation of the load PF increases the current supplied by the shunt converter. The following analysis is valid for an iUPQC acting like a conventional UPQC or including the extra compensation like a STATCOM. First, the circulating power will be calculated when the iUPQC is operating just like a conventional UPQC. Afterward, the equations will include the STATCOM functionality to the grid bus A. In both cases, it will be assumed that the iUPQC controller is able to force the shunt converter of the iUPQC to generate fundamental voltage always in phase with the grid voltage at bus A. For simplicity, the losses in the iUPQC will be neglected. For the first case, the following average powers in steady state can be determined:

$$S_A = P_B$$

$$Q_{shunt} = -Q_B$$

$$Q_{series} = Q_A = 0 \text{ var}$$

$$P_{series} = P_{shunt}$$

where S_A and Q_A are the apparent and reactive power injected in the bus A; P_B and Q_B are the active and reactive power injected in the bus B; P_{shunt} and Q_{shunt} are the active and reactive power drained by the shunt converter; P_{series} and Q_{series} are the active and reactive power supplied by the series converter, respectively. Equations are derived from the constraint of keeping unitary the PF at bus A. In this case, the current passing through the series converter is responsible only for supplying the load active power, that is, it is in phase (or counter phase) with the voltages V_A and V_B . Consequently, the coherence of the power flow is ensured through the equation. If a voltage sag or swell occurs, P_{series} and P_{shunt} will not be zero, and thus, an inner-loop current (inner) will appear. The series and shunt converters and the aforementioned circulating active power (P_{inner}) flow inside the equipment. Thus, demonstrates that P_{inner} depends on the active power of the load and the sag/swell voltage disturbance. In order to verify the effect on the power rate of the series and shunt converters, a full load system $S_B = P_2 + Q_2 = 1 \text{ p.u.}$ with PF ranging from 0 to 1 was considered. It was also considered the sag/swell voltage disturbance at bus A ranging $k_{sag/swell}$ from 0.5 to 1.5. In this way, the power rating of the series and shunt converters. Fig. 6 depicts the apparent power of the series and shunt power converters. In these figures, the $k_{sag/swell}$ -axis and the PF-axis are used to evaluate the power flow in the series and shunt power converters according to the sag/swell voltage disturbance and the load power consumption, respectively. The power flow in the series converter indicates that a high power is required in case of sag voltage disturbance with high active power load consumption. In this situation, an increased P_{inner} arises and high rated power converters are necessary

to ensure the disturbance compensation. Moreover, in case of compensating sag/swell voltage disturbance with high reactive power load consumption, only the shunt converter has high power demand, since P_{inner} decreases. It is important to highlight that, for each PF value, the amplitude of the apparent power is the same for capacitive or inductive loads. In other words, Fig. 6 is the same for Q_B capacitive or inductive. If the iUPQC performs all original UPQC functionalities together with the STATCOM functionality, the voltage at bus A is also regulated with the same phase and magnitude, that is, $V_A = V_B = V_N$, and then, the positive sequence of the voltage at the coupling transformer is zero ($V_{Series} = 0$). Thus, in steady state, the power flow is determined by

$$S_A = P_B + Q_{STATCOM}$$

$$Q_{STATCOM} + Q_{series} = Q_{shunt} + Q_B$$

$$(5) \quad Q_{series} = 0 \text{ var}$$

$$(6) \quad P_{series} = P_{inner} = 0 \text{ W}$$

$$(7)$$

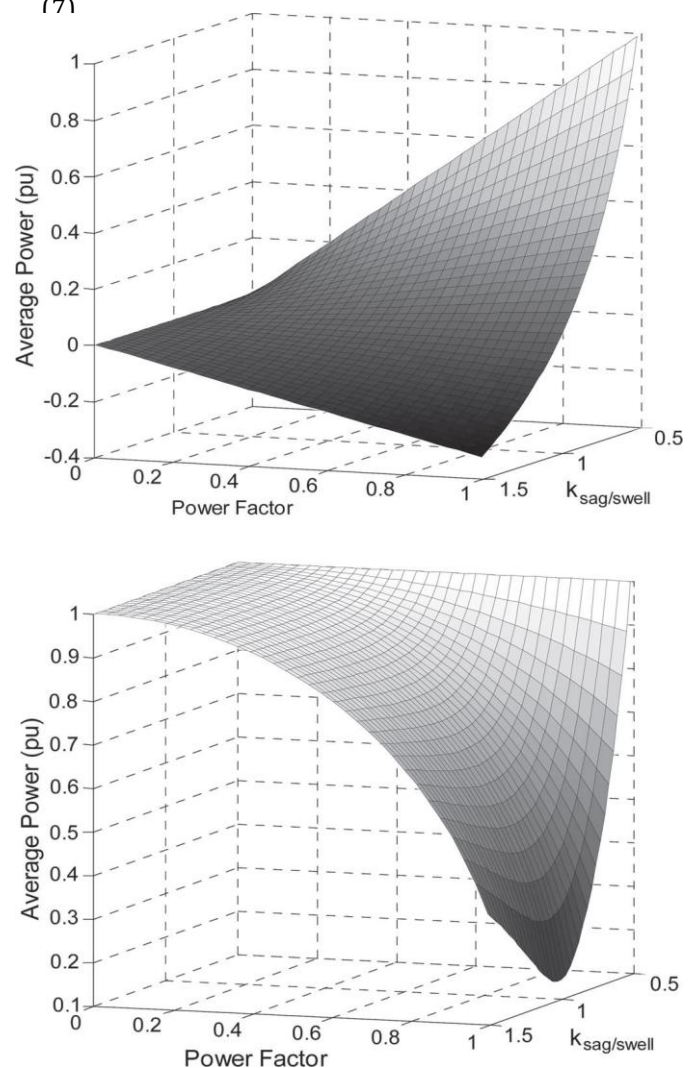

Fig. 6. Apparent power of series and shunt converters

respectively.

where Q STATCOM is the reactive power that provides voltage regulation at bus A. Ideally, the STATCOM functionality mitigates the inner-loop active power flow (P inner), and the power flow in the series converter is zero. Consequently, if the series converter is properly designed along with the coupling transformer to synthesize the controlled currents $I_{+1_α}$ and $I_{+1_β}$, as shown in Fig. 4, then a lower power converter can be employed. Contrarily, the shunt converter still has to provide the full reactive power of the load and also to drain the reactive power injected by the series converter to regulate the voltage at bus A.

2. EXPERIMENTAL RESULTS

To verify the operating performance of the proposed UPQC, a 3-phase electrical system, a fuzzy logic controller with reference signal generation method is designed for UPQC and compared its performance Innovative Systems Design and Engineering. With Artificial neural network based controller is simulated using MATLAB software.

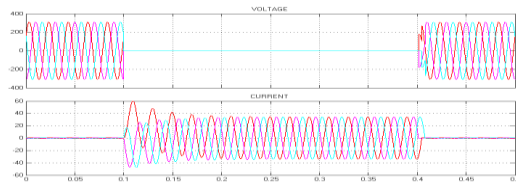

Fig. 7. Input voltage and current

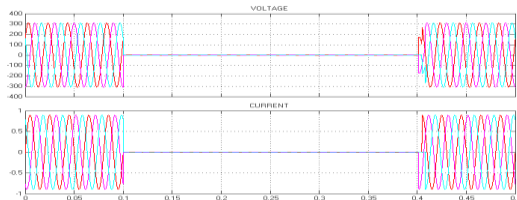

Fig. 8. Output voltage and current

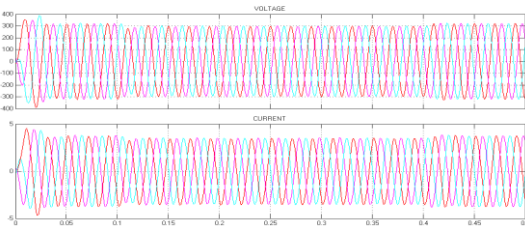

Fig. 9. Controlled voltage and current

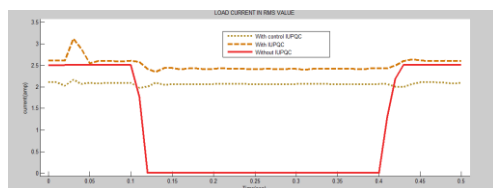

Fig. 10. Load current in RMS value

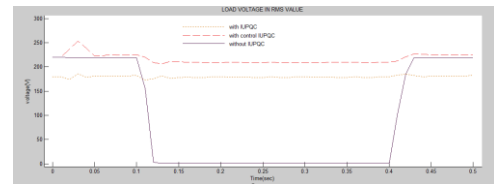

Fig. 11. Load voltage in RMS value

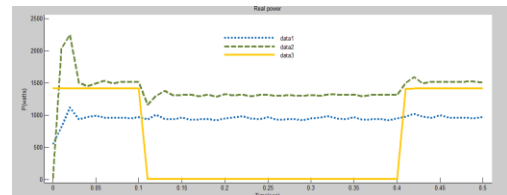

Fig. 12. Real power

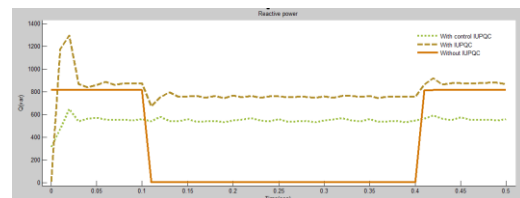

Fig. 13. Reactive power

3. CONCLUSION

In the improved iUPQC controller, the currents synthesized by the series converter are determined by the average active power of the load and the active power to provide the dc-link Voltage regulation, together with an average reactive power to regulate the grid-bus voltage. In this manner, in addition to all the power-quality compensation features of a conventional UPQC or an iUPQC, this improved controller also mimics a STATCOM to the grid bus. This new feature enhances the applicability of the iUPQC and provides new solutions in future scenarios involving smart grids and microgrids, including distributed generation and energy storage systems to better deal with the inherent variability of renewable resources such as solar and wind power.

Moreover, the improved iUPQC controller may justify the costs and promotes the iUPQC applicability in power quality issues of critical systems, where it is necessary not only an iUPQC or a STATCOM, but both, simultaneously. Despite the addition of one more power-quality compensation feature, the grid-voltage regulation reduces the inner-loop circulating power inside the iUPQC, which would allow lower power rating for the series converter.

The simulation results verified the improved iUPQC goals. These results have demonstrated a suitable performance of voltage regulation at both sides of the iUPQC, even while compensating harmonic current and voltage imbalances.

REFERENCES

- [1] K. Karanki, G. Geddada, M. K. Mishra, and B. K. Kumar, "A modified three-phase four-wire UPQC topology with reduced DC-link voltage rating," *IEEE Trans. Ind. Electron.*, vol. 60, no. 9, pp. 3555-3566, Sep. 2013.
- [2] K. H. Kwan, P. L. So, and Y. C. Chu, "An output regulation-based unified power quality conditioner with Kalman filters," *IEEE Trans. Ind. Electron.*, vol. 59, no. 11, pp. 4248-4262, Nov. 2012.
- [3] V. Khadkikar and A. Chandra, "UPQC-S: A novel concept of simultaneous voltage sag/swell and load reactive power compensations utilizing series inverter of UPQC," *IEEE Trans. Power Electron.*, vol. 26, no. 9, pp. 2414-2425, Sep. 2011.
- [4] M. Aredes and R. M. Fernandes, "A dual topology of unified power quality conditioner: The iUPQC," in *Proc. EPE Conf. Appl.*, 2009, pp. 1-10.
- [5] M. Aredes and R. M. Fernandes, "A unified power quality conditioner with voltage sag/swell compensation capability," in *Proc. COBEP*, 2009, pp. 218-224.
- [6] R. J. Millnitz dos Santos, M. Mezaroba, and J. C. da Cunha, "A dual unified power quality conditioner using a simplified control technique," in *Proc. COBEP*, 2011, pp. 486-493.