

Fingerprint Based Attendance Systems-A Review

Hitesh Walia¹, Neelu Jain²

M.Tech. Student, Department of Electronics Engineering, PEC University of Technology, Chandigarh, India¹
Associate Professor, Department of Electronics Engineering, PEC University of Technology, Chandigarh, India²

Abstract- Proper attendance recording and management has become important in today's world as attendance and achievement go hand in hand. Attendance is one of the work ethics valued by employers. Most of the educational institutions and government organizations in developing countries still use paper based attendance method for maintaining the attendance records. There is a need to replace these traditional methods of attendance recording with biometric attendance system. The unique nature of fingerprint makes it ideal for use in attendance management systems. Besides being secure, Fingerprint based attendance system will also be environment friendly. Fingerprint matching is widely used in forensics for a long time. It can also be used in applications such as identity management and access control. This review incorporates the problems of attendance systems presently in use, working of a typical fingerprint based attendance system, study of different systems, their advantages, disadvantages and comparison based upon important parameters.

Key Words: Biometric, Fingerprint, GSM, LabVIEW, MATLAB, RFID, ZigBee

1. INTRODUCTION

Presently, attendance of students in most institutes is taken by the teacher on paper based attendance registers. There are various disadvantages to this approach such as data is not available for analysis because paper based registers are not uploaded to a centralized system, time taken for data collection reduces the effective lecture time and fake attendance by students. Some universities also use wall mounted RFID swipe card systems. RFID (Radio Frequency Identification) is a wireless technology which uses electromagnetic waves for communication between RFID reader and RFID tag. Though better than paper based systems, RFID based systems also have certain problems such as the system is complex, costly and absent student's card can be swiped by other students.

Biometric techniques can be used to solve these problems. Biometric is derived from two Greek roots "bios" meaning life and "metrics" meaning measurement. Biometric

technology identifies a person uniquely based on his/her characteristics which can be physiological or behavioural. Among the various biometric techniques, there are nine main biometric techniques which are widely used. These include fingerprint, face, hand vein, hand geometry, iris, retinal pattern, voice print, signature, and facial thermograms. Comparison of different biometric techniques has shown that fingerprint biometric is a reliable, mature and legally accepted biometric technique [1]. Therefore, Fingerprint based attendance system can be used for identification of large number of students in universities and also for attendance monitoring of employees in organizations.

There are two stages of working of these systems 1) Enrolment of fingerprints. 2) Matching of Fingerprints. The basic steps are shown in Fig. 1

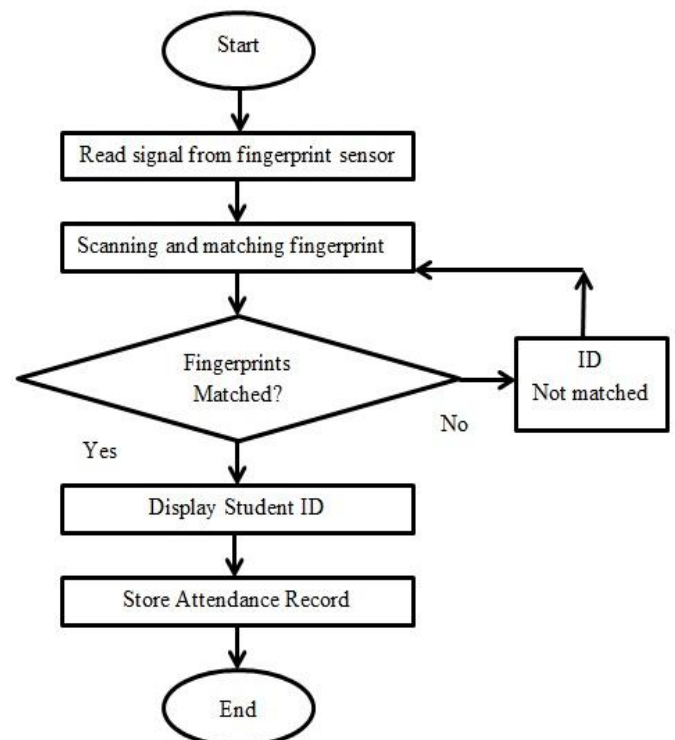

Fig-1: Working of Fingerprint based Attendance System

2. LITERATURE REVIEW

Many researchers have implemented Fingerprint based attendance system which makes use of a Fingerprint sensor/scanner along with other technologies. These systems are classified based on the tools and techniques used to implement the system.

A. LabVIEW

The system is designed using 8051 microcontroller, R305 optical fingerprint sensor and LabVIEW [2]. Block diagram of the system is shown in Fig. 2. Microcontroller communicates with computer in which LabVIEW is installed. RS 232 is used for serial communication between microcontroller and PC. LabVIEW is a system design software from National Instruments which is used in the system for storing attendance records, maintaining it in a text file and displaying it to the user. Student ID is also displayed on the LCD screen after fingerprint matching.

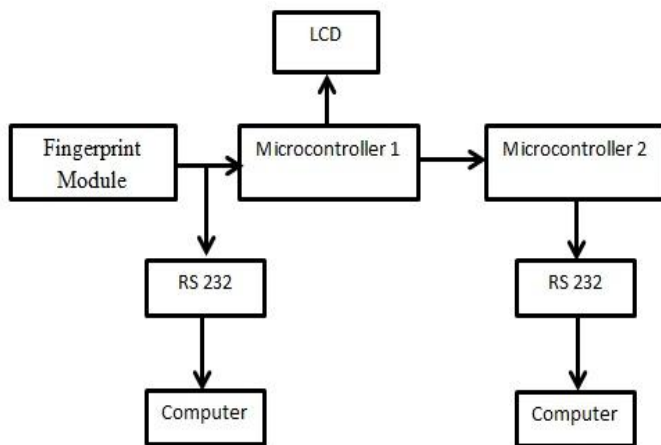

Fig -2: Block diagram of LabVIEW based system [2]

Advantages:

1. User friendly (LabVIEW graphical interface)
2. High speed
3. Efficient and low cost embedded platform
4. Low power consumption
5. Attendance report generation using LabVIEW

Disadvantages:

1. For small databases only
2. Limited Functionality
3. Two microcontrollers are used

B. Internet of things

Hardware of the system includes ARM9 S3C2440 processor board, FPS200 solid state fingerprint sensor as shown in Fig. 3. Database is designed using SQLite database management tool. In addition to fingerprint biometric, Vein recognition is also used [3]. The main function of the system includes automation of attendance and login of grades. Internet of

things is an interaction of devices using internet. It allows for real time attendance data monitoring and processing using a website. Every information regarding attendance records can be obtained from the website.

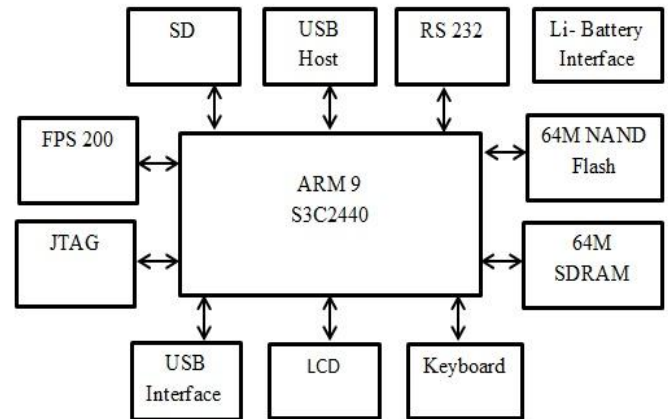

Fig-3 : Hardware block diagram [3]

Advantages:

1. More secure (Additional Vein recognition)
2. Internet of things (Everything can be done online)
3. Information can be accessed anywhere

Disadvantages:

1. Complex software system architecture.
2. High cost

C. GSM and ZigBee

The attendance system shown in Fig. 4 incorporates a low power consumption 2138 microcontroller, SIM 900 GSM module and a ZigBee series 2 OEM RF module [4]. GSM (Global system for mobile communication) and ZigBee are the additional technologies used in this system.

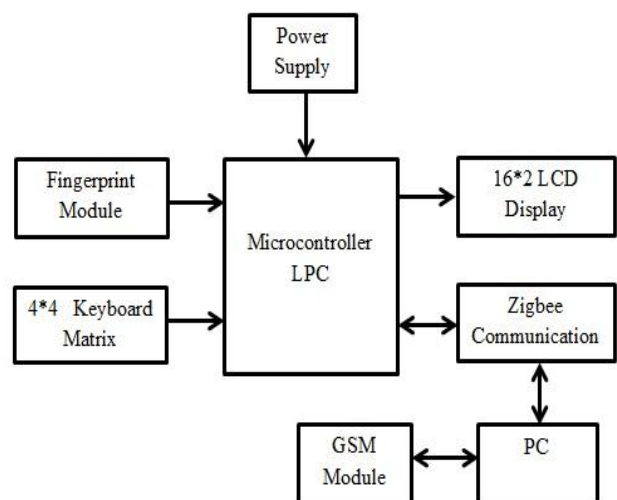

Fig-4: GSM and ZigBee based system [4]

GSM module is used to communicate the daily attendance report of students for every subject along with start time and end time of lecture to head of the department. Parents are also intimated about the attendance of their ward via SMS. ZigBee uses low power radios to transmit and receive the signals wirelessly. Attendance data is transferred from classroom module to centrally located PC via ZigBee. Data is then stored and analysed in the centralized system. Attendance system using only GSM are implemented by [5] [6] and ZigBee based system is implemented by [7].

Advantages:

1. Easy to use.
2. Portable (Wireless)
3. Low power consumption
4. Additional functionality (due to GSM)

Disadvantages:

1. Less range of ZigBee (10-20 metres)
2. Low data rate of ZigBee.
3. High cost (both GSM and Zigbee)

D. RFID and Android

This attendance monitoring system uses RFID technology where student has to swipe RFID card along with his fingerprint to mark the attendance as depicted in Fig. 5. An android application is developed through which system can be accessed from any remote location and record of any student can be checked. The system can also detect the location of students, faculties and other members anywhere inside the campus [8]. Online SMS service is used to inform the parents about student’s attendance.

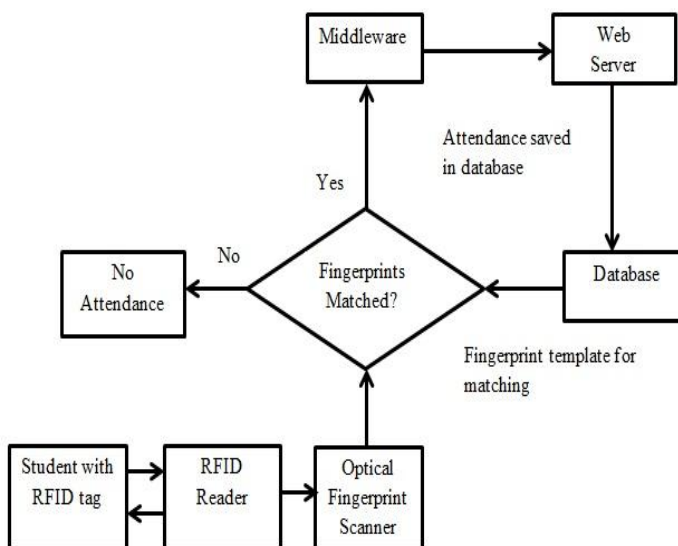

Fig- 5 : Flowchart of attendance recording process [8]

Advantages:

1. More secure (RFID+ Biometrics)
2. More functionality

3. System can be accessed remotely (via android application)
4. Attendance performance graph will be generated
5. RFID cards can serve as library card, mess card
6. RFID cards are difficult to tamper
7. Free bulk SMS service used instead of GSM (Lower cost)

Disadvantages:

1. Complex software design
2. Android application development difficult.

E. ZigBee, DSP and MATLAB

The system comprises of transmitter section, receiver section element and attendance supervision terminal [9]. Transmitter section consists of optical fingerprint sensor OP-100N, ADSP-BF532 & ZigBee transmitter as shown in Fig. 6. Digital signal processor makes the processing faster. Fig. 7 depicts receiver section which consists of ZigBee receiver and microcontroller. Image enhancement is performed using MATLAB. Steps involved in image enhancement are shown in Fig. 8. MS-access and Visual basic are used for database implementation. RF (Radio frequency) module can be in place of ZigBee to increase the range [10].

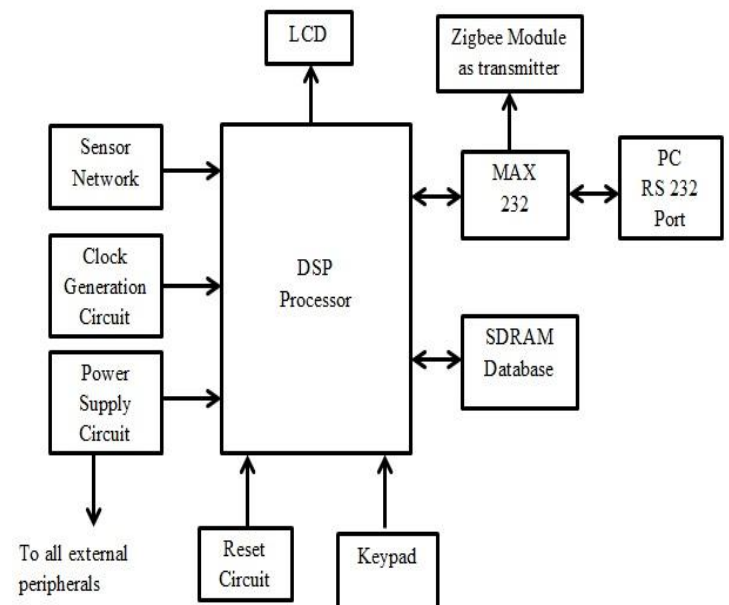

Fig- 6 : Transmitter section block diagram [9]

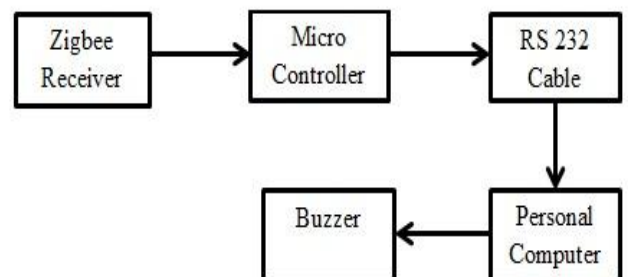

Fig -7 : Receiver section block diagram [9]

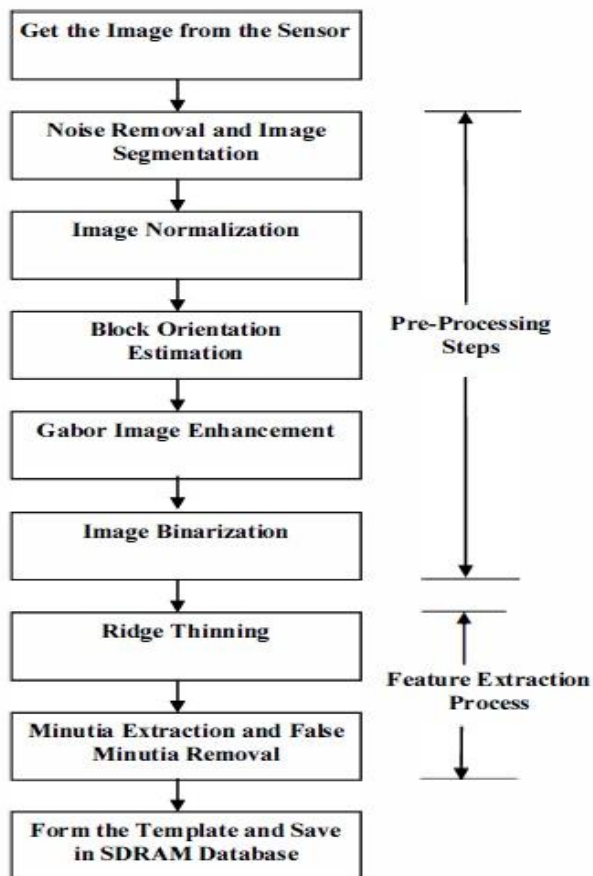

Fig -8 : Image enhancement using MATLAB [9]

Advantages:

1. Low power consumption
2. Good accuracy (Gabor image enhancement).
3. Flexible user modes
4. High resolution of fingerprint sensor
5. Wireless (portable)
6. Low cost

Disadvantages:

1. Three different supply voltages required (3.3V, 5V, 12V)

F. Cryptography

A portable fingerprint attendance system is designed using Arduino board based on ATmega1280. Different blocks of the system are shown in Fig. 9. Fingerprint scanner ZFM 20 is used having its own processor and memory. TFT touch screen provides user friendly interface. SD card is used for storage of student's records. RTC (Real time clock) provides the exact attendance date and time. Caesar Cipher cryptographic technique is used so that data cannot be manipulated by unauthorized user [11].

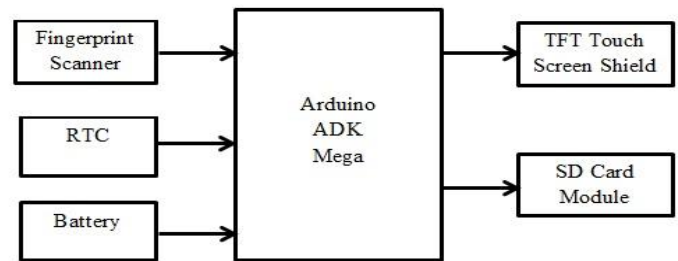

Fig- 9 : Portable Attendance System [11]

Advantages:

1. User friendly design
2. Portable
3. Small size
4. Security enhancement (encryption of data)
5. Faster than fixed fingerprint reader

Disadvantages:

1. Limited battery life
2. Limited Functionality

G. RFID, GSM and .Net

The system combines RFID and GSM technology with biometrics for attendance management. Students ID (identification) card is tagged with their RFID tag. RFID tag is matched with the database and attendance is finalized after fingerprint is verified using fingerprint sensor. GSM Modem is used for sending SMS to parents regarding student's attendance. RFID transponders are installed in classrooms, laboratories and staffrooms through which location of the student and staff can be traced .A website is designed through which teacher, students and guardians can view the location of a student in the campus and also the attendance record of the student. vb.net is used for server application and asp.net for website [12]. System using NFC (Near Field Communication) is implemented by [13]. NFC based system has lower range than RFID based systems.

Advantages:

1. More Secure due to RFID and biometrics
2. Complete system is automated
3. Small size of RFID cards
4. Fast processing speed
5. No line of sight required for RFID
6. Many tags can be read simultaneously
7. .net framework simplifies debugging

Disadvantages:

1. Software design is difficult.
2. System should always be kept ON
3. Costly

3. COMPARATIVE ANALYSIS

Implementation of efficient biometric attendance system requires certain parameters to be satisfied such as high speed, high security and low cost. Existing Fingerprint based Attendance systems are compared on the basis of speed of the system in recording and maintaining attendance, security of the system, power consumption of different units of the system, cost of implementation, portability and functionality in Table I.

Table -1: Comparison of fingerprint based attendance systems

Parameter Technique	Speed	Security	Power Consumption	Cost	Portability	Functionality
LabVIEW	High	Moderate	Low	Low	No	Limited
Internet of things	High	High	Moderate	High	No	Wide
GSM, ZigBee	Moderate	Moderate	Low	High	Yes	Wide
RFID, Android	High	High	Moderate	High	No	Wide
ZigBee, DSP, MATLAB	High	Moderate	Low	Low	No	Limited
Cryptography	High	High	Low	Low	Yes	Limited
RFID, GSM, .Net	High	High	Moderate	High	No	Wide

Comparison shows that more functionality requires more complex circuit and difficult software development. There is a tradeoff between speed and power consumption and also between large databases and accuracy of fingerprint matching. Parameters required for a particular application varies and this comparison table can be used to make a proper choice for the implementation of Fingerprint based attendance system. Different technologies can be combined to implement a system an efficient and ease to use system.

4. CONCLUSION

Biometric technology is a reliable tool for authentication. Various fingerprint based attendance systems have been reviewed .Some of the systems look promising to be practically implemented in developing countries. The existing systems can further be improved or combined which helps in making the system more user friendly, secure and fast. Low cost embedded platform can be combined with the user friendliness of LabVIEW and added functionality of GSM technology.

REFERENCES

[1] A. Jain, L. Hong, S. Pankanti, and R. Bolle , “An Identity Authentication System Using Fingerprints”, Proceedings of the IEEE, Vol. 85, Issue 9, 1997, pp. 1365-1388.
 [2] D.K. Yadav, S. Singh, S. Pujari, and, P. Mishra, “Fingerprint Based Attendance System Using Microcontroller and

LabView”, International Journal of Advanced Research in Electrical, Electronics and Instrumentation Engineering, Vol. 4, Issue 6, 2015, pp. 5111-5121.

[3] Wang and Jingli , “The Design of Teaching Management System in Universities Based on Biometrics Identification and the Internet of Things Technology”, IEEE 10th International Conference on Computer Science & Education (ICCSE), Cambridge University, UK July 22-24, 2015, pp. 979-982.

[4] M.P. Potadar, V.V. Marathe , A.S. Khose, and L.A. Kotkar, “Biometric Attendance Recording and Communication System”, International journal of innovations in engineering and technology(IJiet) , Vol. 5, Issue 2, 2015, pp. 230-234.

[5] P. Verma and N. Gupta , “Fingerprint Based Student Attendance System Using GSM”, International Journal of Science and Research (IJSR), Vol. 2, Issue 10, 2013, pp. 128-131.

[6] K. Jaikumar, M.S. Kumar, S. Rajkumar , and A. Sakthivel , “Fingerprint Based Student Attendance System With Sms

Alert To Parents”, International Journal of Research in Engineering and Technology (IJRET), Vol. 4, Issue 2, 2015, pp. 293-297.

[7] G. Talaviya, R. Ramteke, and A.K. Shete, “Wireless Fingerprint Based College Attendance System Using Zigbee Technology”, International Journal of Engineering and Advanced Technology (IJEAT), Vol. 2, Issue 3, 2013, pp. 201-203.

[8] M.B. Srinidhi and R Roy, “A Web Enabled Secured System for Attendance Monitoring and Real Time Location Tracking Using Biometric and Radio Frequency Identification (RFID) Technology”, IEEE International Conference on Computer Communication and Informatics (ICCCI), Coimbatore, India, Jan. 08- 10, 2015

[9] M. Kamaraju and P.A. Kumar, “Wireless Fingerprint Attendance Management System”, IEEE International Conference on Electrical Computer and Communication Technologies (ICECCT), March 5-7, 2015.

[10] U. Farooq, M. Amar , H.R. Ibrahim, N. Khalid, S. Nazir, and M.U. Asad, “Cost Effective Wireless Attendance and Access Control System, IEEE 3rd International Conference on Computer Science and Information Technology (ICCSIT)”, July 9-10,2010, pp.475-479.

[11] N.I. Zainal, K.A. Sidek, T.S. Gunawan, and H.M.M. Kartiwi , “Design and development of portable classroom attendance system based on Arduino and fingerprint Biometric”, IEEE International conference on information and communication Technology for the Muslim world, Nov. 17-18, 2014.

[12] A.N. Ansari, A. Navada, S. Agarwal, S. Patil, and B. Sonkamble, “Automation of Attendance system using RFID ,Biometrics, GSM modem with . Net framework”, IEEE International conference on multimedia technology, July 26-28, 2011, pp. 2976-2979.

[13] B. Benyo, B. Sodor , T. Doktor, and G. Fordos, “ Student attendance monitoring at the university using NFC” , IEEE Wireless Telecommunications Symposium (WTS), April 18-20,2012.