

# PV Based Switched Boost Inverter with Simultaneous DC and AC Outputs

Vijay Kumar. K<sup>1</sup>, Mahadevi Biradar<sup>2</sup>

<sup>1</sup> PG Scholar

<sup>2</sup> Associate Professor

Department of Electrical Engineering, Poojya Dodappa Appa College of Engineering, Gulbarga, Karnataka, India

**Abstract**— Switched boost inverter (SBI) is a single stage power converter derived from Inverse Watkins Johnson topology. Unlike the traditional buck-type voltage source inverter (VSI), the SBI can produce an ac output voltage that is either greater or less than the available dc input voltage. Also, the SBI exhibits better electromagnetic interference noise immunity when compared to the VSI, which enables compact design of the power converter. Another advantage of SBI is that it can supply both dc and ac loads simultaneously from a single dc input. These features make the SBI suitable for dc nano grid applications. In this paper, the SBI is proposed as a power electronic interface in dc nanogrid.

**Keywords**— photovoltaic system, switched boost inverter(SBI), PWM, VSI.

## I. INTRODUCTION

Renewable and sustainable energy sources such as photovoltaic (PV) require power electronic conditioning. PV generation system is considered as a clean and environmentally friendly source of energy. The output of the PV cells is typically an unregulated low-level DC voltage that needs to be stepped up to a regulated higher level for many potential practical applications and boost converter stages are employed for this purpose. Switched Boost Inverter (SBI) is a single stage DC to AC power converter and it is derived from the Z - source inverter employs an LC impedance network in between the main inverter bridge and the power source. This SBI converter can possible to supply both DC and AC loads simultaneously from a single dc input source. Here, reducing the inverter switching stress. Also, this converter provides to shoot through of the inverter legs without causing any damage to the inverter switches. The unique

feature of the SBI, it can operate either in buck or boost mode operations with a wide range of obtainable output voltages from a given input voltage, unlike the traditional buck type voltage source inverter.

## II.SOLAR PHOTOVOLTAIC SYSTEM

The European PV industry Association reported that the total global PV cell production worldwide in 2002 Maintaining the Integrity of the Specifications was over 560 MW and has been growing about 30% annually in recent years. The physical of PV cell is very similar to that of the classical diode with a PN junction formed by semiconductor material. When the junction absorbs light, the energy of absorbed photon is transferred to the electron-proton system of the material, creating charge carriers that are separated at the junction. The charge carriers in the junction region create a potential gradient, get accelerated under the electric field, and circulate as current through an external circuit. The solar cell is the basic building of the PV power system it produces about 1 W of power. To obtain high power, numerous such cell are connected in series and parallel circuits on a panel (module), the solar array or panel is a group of a several modules electrically connected in series parallel combination to generate the required current and voltage. The electrical characteristics of the PV module are generally represented by the current vs. voltage (I-V) and the current vs. power (P-V) curves. Fig.1 and Fig.2. show the (IV) and (P-V) characteristics of the used photovoltaic module at different solar illumination intensities.

The I- V characteristic of the PV module are:

$$I = I_L - I_0 (e^{q(V + I R_S) / nkT} - 1)$$

Where,

$I_L$  = photo current

$I_0$  = diode saturation current  
 $R_S$  = series resistance  
 $q$  = charge of electron  
 $k$  = constant  
 $T$  = temperature  
 $N$  = number of PV module

Power output from the PV array can be obtained by using the equation:

$$P_{pv}(t) = I_{ns}(t) * A * \text{Eff}(pv).$$

Where,

$I_{ns}(t)$  = insulation data at time  $t$  ( $\text{kw}/\text{m}^2$ )  
 $A$  = area of single PV panel ( $\text{m}^2$ )  
 $\text{Eff}(pv)$  = overall efficiency of the PV panels and dc/dc converters.

The Solar Cell Characteristics:

- $I_{sc}$ -short circuit current
- $V_{oc}$ -open circuit voltage
- Peak power  $P_{pv}$  The open circuit voltage of a single solar cell is approx 0.5V.
- Much higher voltage is required for practical application.
- Solar cells are connected in series to increase its open circuit voltage.

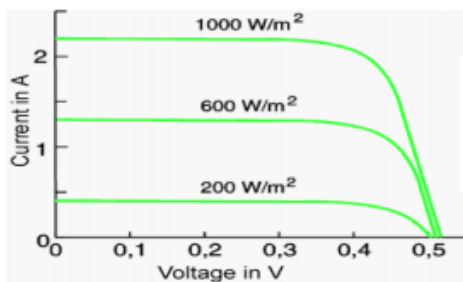

Fig.1.The electrical characteristics of PV module: current versus voltage.

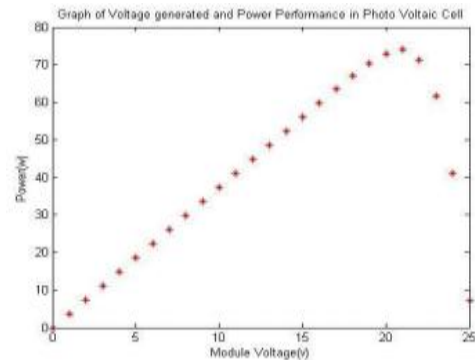
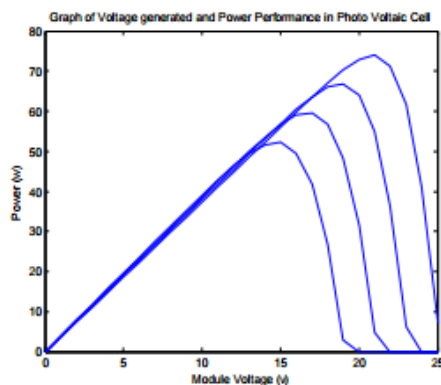

Fig.2.The electrical characteristics of PV module: power versus module voltage.

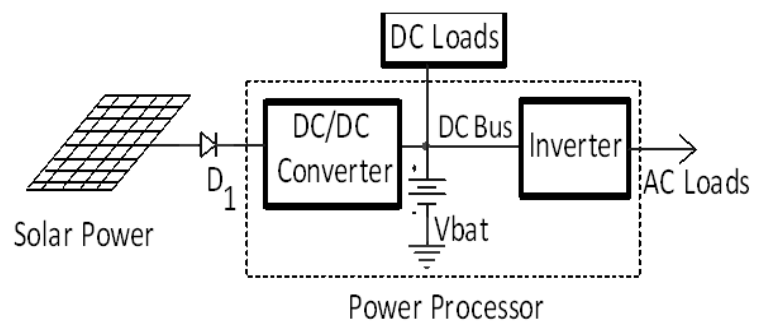

Fig.3.Architecture of a typical PV Based MICROGRID

Microgrid is a small autonomous system formed by integrating various distributed energy sources like solar, wind, fuel cells, biomass, etc. Fig.3 shows the architecture of a typical solar microgrid. As shown in Fig.3 a power processor with power electronic converters is used to convert the power generated by the solar panel to consumer usable power. Unlike the traditional AC grid which can supply only AC loads, the microgrid can supply both DC and AC loads simultaneously.

### III. PROPOSED TOPOLOGY

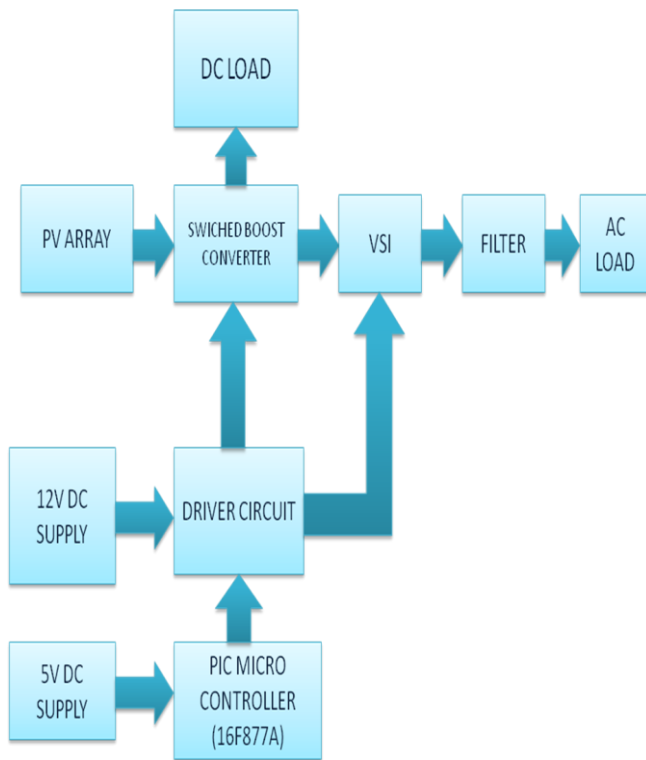

Fig.4. Block Diagram of Switched Boost Inverter

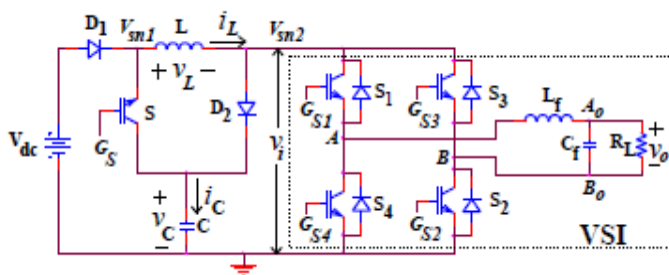

Fig.5. Schematic of the Switched-Boost Inverter

Fig.4 shows the block diagram of the PV based switch boost inverter with simultaneous AC and DC output and Fig.5 shows the schematic of the switched boost inverter in which a switched boost network comprising of one active switch (S), two diodes (D1, D2), one inductor (L) and one capacitor (C) is connected between voltage source  $V_{dc}$  and the VSI. A low pass LC filter is used at the output of the VSI to filter the switching frequency components in the inverter output voltage  $V_{ab}$ . Similar to a Z source inverter, the switched-boost inverter also utilizes the shoot-through

state of the H-Bridge inverter (both switches in one leg of the inverter are turned on simultaneously) to boost the input voltage  $V_{dc}$  to  $V_c$ .

In this paper to explain the operation of the switched boost inverter, assume that the inverter is in shoot-through zero state for duration (DTs) in a switching cycle  $T_s$ . The switch S is also turned on during this interval. As shown in the equivalent circuit diagram 1 in Fig.6, the VSI is represented by a short circuit during this interval. The diodes D1 and D2 are reverse biased (as  $V_c > V_{dc}$ ) and the capacitor C charges the inductor L through switch S and the inverter bridge. The inductor current in this interval equals the capacitor discharging current.

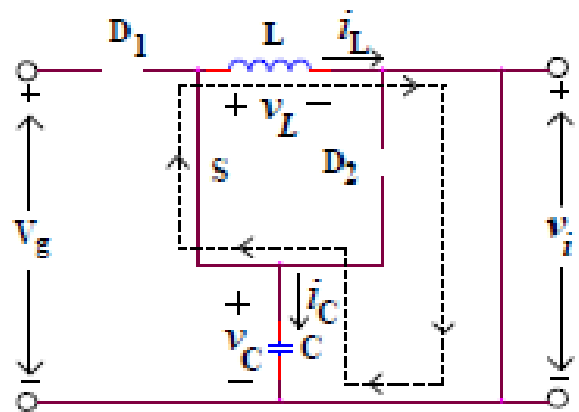

Fig.6. Equivalent circuit diagram 1

For next switching cycle,  $(1-D) \cdot T_s$ , the inverter is in non shoot through state and the switch S is turned off. The inverter bridge is represented by a current source in this interval as shown in the equivalent circuit diagram 2 in Fig. 7. Now the voltage source  $V_{dc}$  and inductor L together supply power to the inverter and the capacitor through diodes D1 and D2. The inductor current in this interval equals the capacitor charging current added to the inverter input current. Note that the inductor current is assumed to be sufficient enough for the continuous conduction of diodes D1, D2 for the entire interval  $(1-D) T_s$ .

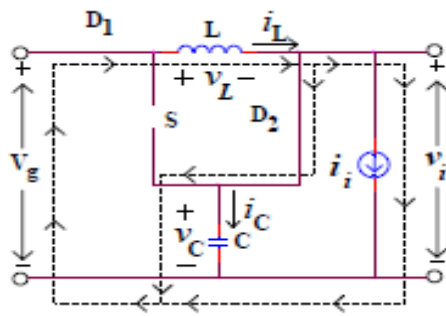

Fig. 7. Equivalent circuit diagram 2

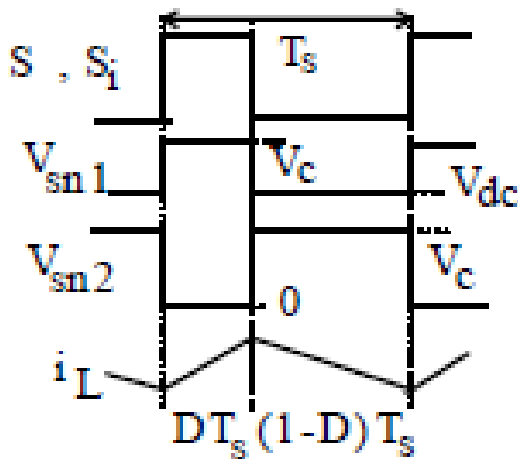

Fig.8. Steady state waveforms

Fig.8.shows the steady state waveforms of the converter operation for one switching cycle  $T_s$ .

From Fig. 6 and 7, the voltage across the inductor L in one switching time period  $T_s$  is given by

$$V_L(t) = \begin{cases} V_C & \text{during } DT_s \\ V_{DC} - V_C & \text{during } (1 - D)T_s \end{cases}$$

Under steady state, the average voltage across the inductor in one switching cycle should be zero. Using this volt-sec balance,

$$V_C \cdot D + (V_{dc} - V_C) \cdot (1 - D) = 0$$

$$\text{OR, } \frac{V_C}{V_{dc}} = \frac{1-D}{1-2D}$$

#### IV. PWM CONTROL OF SBI

The SBI utilizes the shoot through interval of the H-bridge to invoke the boost operation. So, the traditional PWM techniques of VSI have to be modified to incorporate the shoot-through state, so that they are suitable for SBI. In a PWM scheme for SBI is developed based on the traditional sine-triangle PWM with uni polar voltage switching. This technique has been illustrated in Fig.9 during positive and negative half cycles of the sinusoidal modulation signal  $V_m(t)$ .

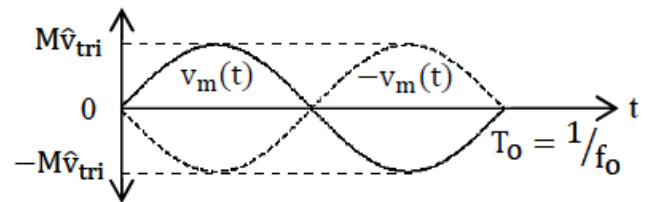

(a)

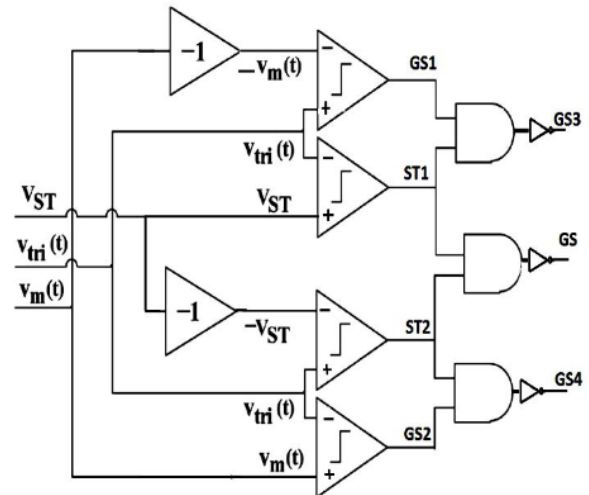

(b)

As shown in Fig. 9(b) and (c), the gate control signals GS 1 and GS 2 are generated by comparing the sinusoidal modulation signals  $V_m(t)$ , and  $-V_m(t)$  shown in Fig. 9(a) with a high-frequency triangular carrier  $V_{tri}(t)$  of amplitude  $V_{tri}$ . The frequency  $f_s$  of the carrier signal is chosen such that  $f_s > f_o$ . Therefore,  $V_m(t)$  is assumed to be nearly constant during a switching cycle.

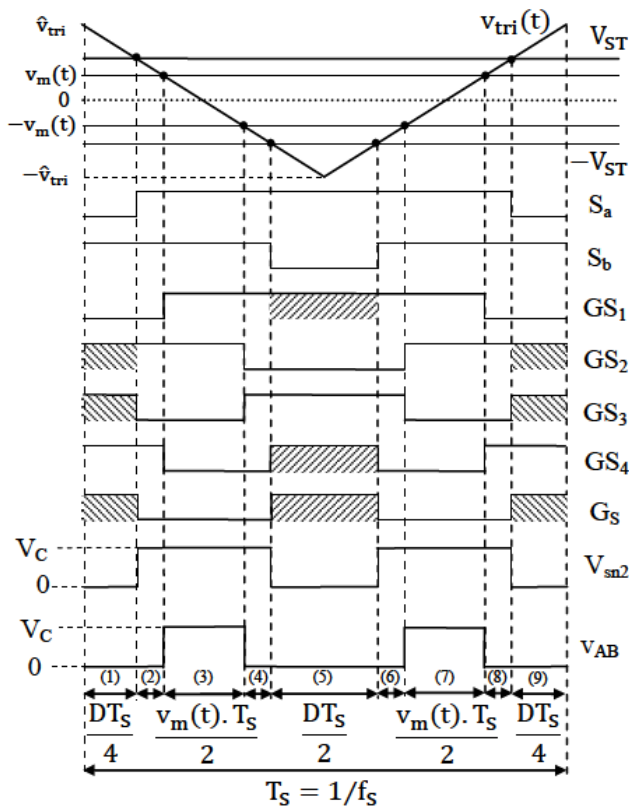

(c)

Fig.9. (a) Sinusoidal Modulation Signals  $V_m(t)$  and  $-V_m(t)$  (b) schematic of the control circuit to generate the PWM control signals.(c) Generation of gate control signals for SBI

The signals  $ST1$  and  $ST2$  are generated by comparing  $V_{tri}(t)$  with two constant voltages  $V_{ST}$  and  $-V_{ST}$  respectively. The purpose of these two signals is to insert the required shoot through interval  $DTS$  in the PWM signals of the inverter bridge. Now the gate control signals for switches  $S3$ ,  $S4$  and  $S$  can be obtained using the logical expressions given as follows:

$$GS\ 3 = GS\ 2 + ST1; GS\ 4 = GS\ 1 + ST2; GS = ST1 + ST2$$

Similarly, as shown in Fig. 9(b) and (c), the gate control signals  $GS3$  and  $GS4$  are generated by comparing the modulation signals  $-V_m(t)$ , and  $V_m(t)$  with the triangular carrier  $V_{tri}(t)$ . The shoot through signals  $ST1$  and  $ST2$  are generated in the same manner as in the positive half cycle. The gate control signals for switches  $S1$ ,

$S2$  and  $S$  can be obtained using the logical expressions given as follows:

$$GS\ 1 = GS\ 4 + ST1; GS\ 2 = GS\ 3 + ST2; GS = ST1 + ST2$$

### V. SIMULATION RESULTS

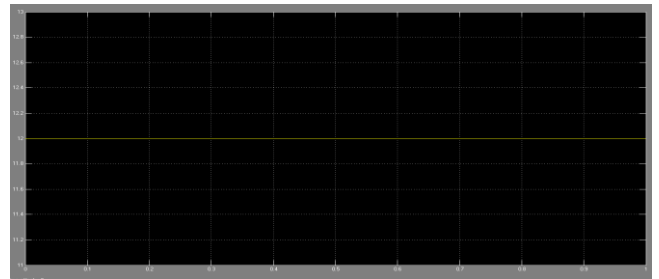
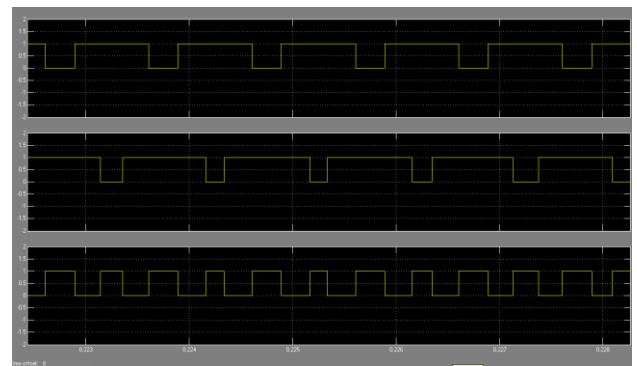
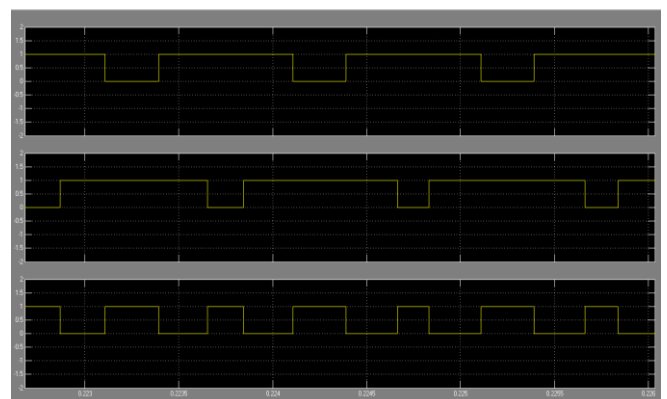

Fig.10. Solar input DC voltage



[a]



[b]

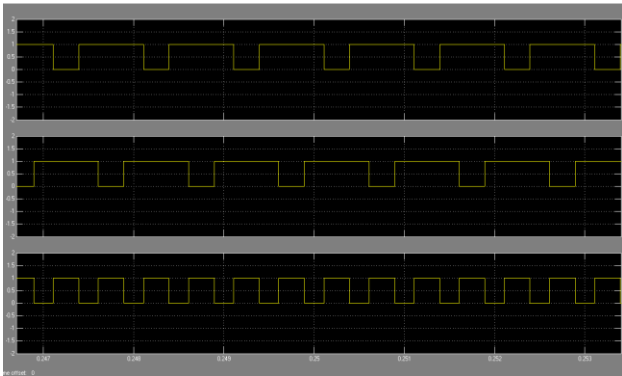

[c]

Fig.11. [a] Generation of short-through in Leg A, i.e. Sb, Gs1, Gs4 [b] Generation of short-through in Leg B, i.e. Sa, Gs2, Gs3 [c] Generation of gate signal for switch S i.e. Sa, Sb, Gs

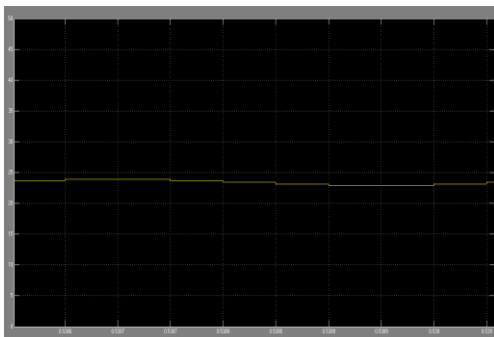

Fig.12. Capacitor Voltage Vc

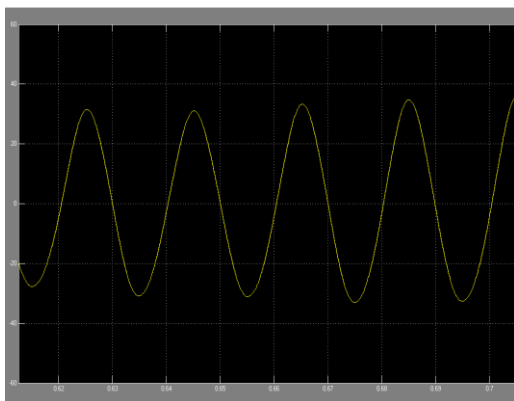
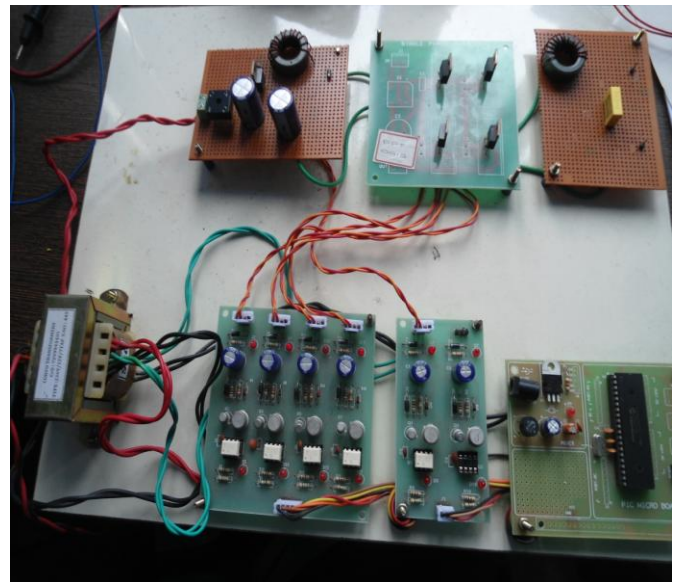

Fig.13. Load Voltage Vo

To get simulation result we developed simulation module in MATLAB software version R2012b. In simulation run the model by clicking simulation in the tool

bar then click on run, after the run is completed it shows 100%, then click on the scope to view the input and output waveforms and the values are displayed in the display block. Solar input power shown in Fig.10. Fig.11 shows generation of short-through in Leg A, Leg B and Switch S. The voltage across the capacitor is shown in Fig.12 and output load voltage shown in fig.13.

**V. EXPERIMENT SETUP AND ITS RESULT**



In this proposed system, the 16F877A PIC microcontroller is used to provide the gate pulses for switches of the Switched Boost Inverter and Voltage Source Inverter. We can give 12V dc input directly from Solar panel or for experiment can give 12V input from Rectifier Converter. When we give gate pulses the VSI, it act as short-through and in SBI the capacitor gets to charge and the inductor L through switch S and the inverter bridge. The inductor current in this interval equals the capacitor discharging current. For the remaining duration in the switching cycle, the inverter is in non shoot through state. The voltage source Vdc and inductor L together supply power to the inverter and the capacitor through diodes D1 and D2. The inductor current in this interval equals the capacitor charging current added to the inverter input current. The output voltage Vo is measured at load.

Parameter	Value		
	Simulation	Experimental	
V <sub>dc</sub>	12V	12V	
V <sub>c</sub>	24V	23V	
V <sub>o</sub>	20V	19.5V	
V <sub>sn1</sub>	If S is ON	175V	-
	If S is OFF	60V	-
V <sub>sn2</sub>	If S is ON	0V	-
	If S is OFF	175V	-

## VI. CONCLUSION

This paper presents the steady state analysis for switched boost inverter (SBI) for DC nanogrid applications as well as home applications. It shown that SBI is a single stage power converter that can supply both dc and ac loads simultaneously from a single dc input. The PWM control technique is implemented using simple analog circuit. The operating principle and analysis have been given. A simulation module is designed and verified operation with the experimental prototype hardware module results. This module can incorporate in modern residential electrical power system. The PV arrays can make it suitable for various applications such as renewable power systems, adjustable speed drive systems and uninterruptible power supplies.

## REFERENCES

- [1] Ravindranath Adda, Santanu Mishra and Avinash Joshi "A PWM Control Strategy for Switched Boost Inverter" in *Proc. 3rd IEEE Energy Convers. Congr.Expo.*, Phoenix,AZ, 2011, pp. 4208–4211
- [2] Olive Ray and Santanu Mishra "Boost-Derived Hybrid Converter with Simultaneous DC and AC Outputs" in *IEEE TRANSACTIONS ON INDUSTRY APPLICATIONS*, VOL. 50, NO. 2, MARCH/APRIL 2014 pp. 1082-1093
- [3] Alan Joseph, JinWang and Fang Zheng Peng "Z-Source Inverter for Motor Drives" *IEEE TRANSACTIONS ON POWER ELECTRONICS*, VOL. 20, NO. 4, pp. 857-863 in JULY 2005
- [4] Luo Fang Lin, Chandana Jayampathi Gajanayake and Gooi Hoay Beng "Extended boost Z-source inverters" *IEEE Transactions on Industry Applications*, pp. 3845-3852, Nov-2009
- [5] Santanu Mishra, Ravindranath Adda and Avinash Joshi "Inverse Watkins–Johnson Topology-Based Inverter" *IEEE TRANSACTIONS ON POWER ELECTRONICS*, VOL. 27, NO. 3, pp. 1066-1070 Mar.2012
- [6] Fang Zheng Peng, Miaosen Shen and Zhaoming Qian "Maximum Boost Control of the Z-Source Inverter" in *IEEE TRANSACTIONS ON POWER ELECTRONICS*, VOL. 20, NO. 4, JULY 2005 pp. 833-838
- [7] Adda Ravindranath, Santanu K. Mishra, Avinash Joshi "Analysis and PWM Control of Switched Boost Inverter" *IEEE TRANSACTIONS ON INDUSTRIAL ELECTRONICS*, VOL. 60, NO. 12, DECEMBER 2013 pp. 5593-5602.
- [8] C. J. Gajanayake, F. L. Luo, H. B. Gooi, P. L. So, and L. K. Siow, "Extended-boost Z-source inverters," *IEEE Trans. Power Electron.*, vol. 25, no. 10, pp. 2642–2652, Oct. 2010.