

# DETECTION AND PROTECTION OF POWER GRID SYNCHRONIZATION FAILURE

**Rohan Solanki, Divyesh Patel, Yuvraj Gharia, Daivik Sailor, Bhumit Patel, Ashish Chaudhari**

*B.Tech, Dept. of Electrical Engineering, CGPIT, Gujarat, India  
 B.Tech, Dept. of Electrical Engineering, CGPIT, Gujarat, India  
 B.Tech, Dept. of Electrical Engineering, CGPIT, Gujarat, India  
 B.Tech, Dept. of Electrical Engineering, CGPIT, Gujarat, India  
 B.Tech, Dept. of Electrical Engineering, CGPIT, Gujarat, India  
 Assistant Professor, Dept. of Electrical Engineering, CGPIT, Gujarat, India*

**Abstract** – There are several power generating units connected to grid such as hydro, thermal, solar, etc. to supply power to the load these generating units need to supply power according to the rules of L.D.C these rules involves maintaining voltage variation with in limit and also the frequency if any deviation from the acceptable range limit of the grid it is mandatory that the some feeder should automatically get disconnected from the grid which in termed as islanding, these prevent in large scale brownout or blackout of the grid power so it is preferable to have a system which can warn the grid in advance so that alternate arrangements are kept on standby to avoid complete grid failure.

**Key Words:** - blackout, islanding, grid, LDC, grid failure.

## 1. INTRODUCTION

In India we have five national grids, Western grid, Eastern grid, North-East grid, Southern grid, Northern grid. Northern grid, Eastern grid, North-East grid, Western grid are synchronized with each other and southern grid is asynchronous. For synchronization of all power generating station with State as well as National power grid we have selected three parameters voltage, frequency and phase angle between voltage and current if any of these parameters is violated due to any abnormality or fault the power station will not be able to fulfill all the three condition for synchronizations so it will get asynchronized with grid. As a terminal voltage of the generator will drop and frequency will also be reduced due to abnormality such as overloading. We have interconnected system if one power station is shutdown the whole load of that power station is shifted to other power station, if that power station fails to fulfill the required demand it can again result into synchronization failure with grid in such a way we may have cascade tripping which can result into large blackout so we need a system which can detect the parameters and disconnects the access amount of load. In this project we are introducing a system which detects the voltage and

frequency if suppose voltage or frequency goes out of their acceptable limits the system will give signal to relay to operate and disconnect the load.

## 2. BLOCK DIAGRAM

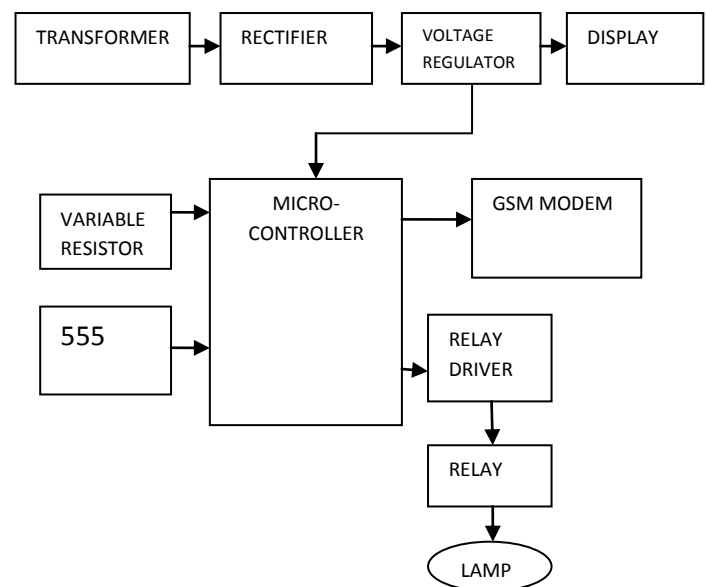

Fig 1-Block diagram

## 3. LIST OF COMPONENT

- Transformer.
- Rectifier.
- Voltage regulator.
- Display.
- Microcontroller.
- 555 IC.
- Variable resistor.
- I.C ULN 283.
- IC MAX 232.
- Relay.

- GSM modem.
- Lamp.

**4. WORKING OF BLOCK DIAGRAM**

As shown in block diagram the whole circuit is divided into two sections supply section and control section, supply section consists of transformer, voltage regulator (7805-7812), rectifier, variable resistor, 555 IC.

The control section consists of microcontroller, relay driver (ULN 283), relay, GSM modem, and lamp.

Detection of voltage and operation of relay- Variable resistor is used to vary the voltage we have consider 3V as a standard voltage in this project, over and below 3V we consider over and under voltage, if we vary the resistance of the variable resistor we can achieve the values below 3V and above 3V, this change in voltage is detected by controller it will send signal to relay driver and relay driver will operate the relay and the access of load will disconnect, the bulb will turn off as an indication of the operation of relay.

Detection of frequency and operation of relay- In this project we have used IC555 as a source of frequency, with the help of variable resistor we can change the frequency from the IC555 in this project we have considered frequency band of 48-52 Hz as a frequency limit, frequency over and below this range will be detected by controller and controller will give signal to relay driver, and relay driver will drive the relay. And the access of load would be disconnected; the bulb will turn off as an indication of the operation of relay.

**5. SIMULATION RESULTS**

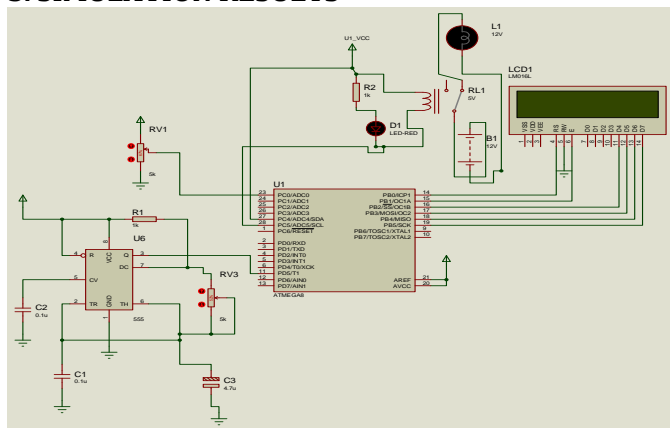

Fig 2- Circuit diagram

**VOLTAGE**

- NV-normal voltage.
- HV-higher voltage.

- LV-under voltage.

**FREQUENCY**

- NF-normal frequency.
- HF-higher frequency.
- LF-lower frequency.

**RELAY**

- R: 0 relay operate.
- R: 1 relay did not operate.

NV, NF, R1

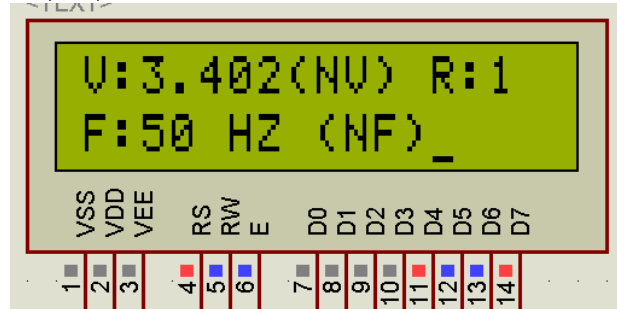

Fig 3- Normal voltage, Normal Frequency

OV, NF, R0

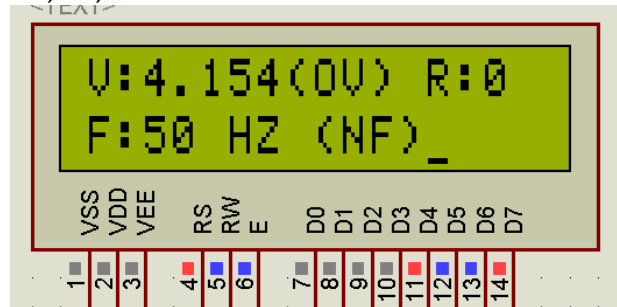

Fig 4-Over Voltage, Normal Frequency

LV, NF, R0

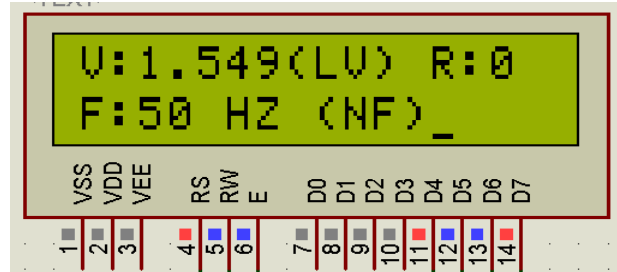

Fig 5-Lower Voltage, Normal Frequency

NV, LF, R0

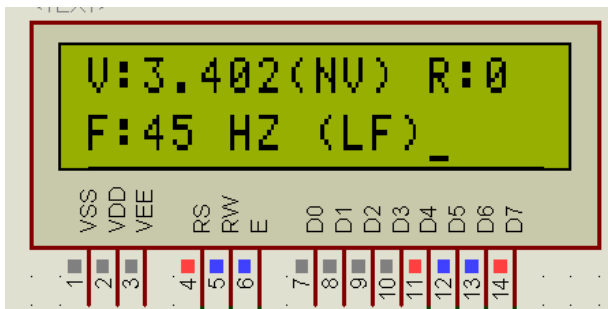

Fig 6-Normal Voltage, Lower Frequency

NV, HF, R0

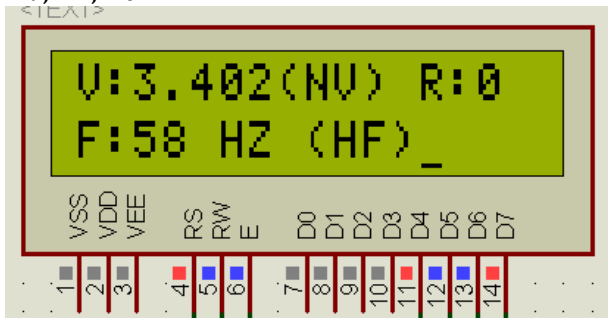

Fig 7-Normal voltage, High Frequency

**CONCLUSION**

It has been concluded that the Generator can be protected from getting asynchronies with power grid by detecting voltage and frequency, by cutting off the excess load which is disturbing the generator.

**ACKNOWLEDGEMENT**







The work carried out in this paper could not be achieved without the contribution and encouragement from the following peoples. Their help has been much appreciated. We would like to express our deep sense of gratitude to our guide Mr. Ashish B.Chaudhari for his valuable guidance, motivation and extreme co-operation to complete our project work successfully, last but not the least we would like to thank our parents who have been a pillar of support.

**REFERENCES**

- [1] Hao Tian Zhang, Chun Sing Lai, S.Mishra, "Investigation on July 2012 Indian Blackout", ICMLC, volume 1, July 2013.
- [2] Vivek Pandey, "Electricity grid management in India", vol 47 No 11, November 2007.
- [3] Power system Dynamic performance committee, power system stability subcommittee, Task force on large interconnected power system, response to generation governing, "Interconnected power system response to generation governing: present practice and outstanding concerns," IEEE, May 2007

- [4] Srinu Naik Ramavath, Venkata Tej Datla and Harshitha Pasagadi, "Islanding scheme and auto load shedding to protect power system," volume 1, issue 4 2013.
- [5] "Tata power company's islanding scheme for Mumbai," June 2007.
- [6] S.R.Balan, P.Sivanesan, B.Ananthakannan, "GSM based automatic substation load shedding and sharing using programmable switching control."

**BIOGRAPHIES**

	<p><b>Rohan M Solanki</b> He is pursuing B.Tech Degree in Electrical Engineering from Chhotubhai Gopalbhai Patel Institute of Technology, Bardoli, Gujarat. His area of interest is power system, electrical machines, power electronics, switch gear and protection.</p>
	<p><b>Divyesh P Patel</b> He is pursuing B.Tech Degree in Electrical Engineering from Chhotubhai Gopalbhai Patel Institute of Technology, Bardoli, Gujarat. His area of interest is power system.</p>
	<p><b>Yuvraj D Gharia</b> He is pursuing B.Tech Degree in Electrical Engineering from Chhotubhai Gopalbhai Patel Institute of Technology, Bardoli, Gujarat. His area of interest is electric traction system and switch gear.</p>
	<p><b>Bhumit A Patel</b> He is pursuing B.Tech Degree in Electrical Engineering from Chhotubhai Gopalbhai Patel Institute of Technology, Bardoli, Gujarat. His area of interest is power system.</p>
	<p><b>Daivik S Sailor</b> He is pursuing B.Tech Degree in Electrical Engineering from Chhotubhai Gopalbhai Patel Institute of Technology, Bardoli, Gujarat. His area of interest is power electronics and power system.</p>
	<p><b>Ashish B Chaudhari</b> Currently he is working as an assistant professor in Chhotubhai Gopalbhai Patel Institute of Technology, Bardoli, Gujarat. His area of interest is power electronics, electrical drives, power system and electrical machines</p>