

RESIDUAL STRESS MEASUREMENT USING HOLE-DRILLING METHOD

A.Senthilmurugan¹ K.Arasu²

Department of Mechanical Engineering,

Bannari Amman Institute of Technology, Sathyamangalam-638401

Abstract: Residual stresses in a welded component can cause distortion and dimensional instability which in turn affects the reliability and fatigue life of the component. Detailed knowledge of residual stresses would be helpful in assessing functional needs of the component. Different methods are available to measure residual stresses. Among these methods, the hole-drilling technique is found to be simple and cost effective. The ASTM E837-08 standard gives necessary guidance and procedure to be followed in the measurement of strains and in turn the calculation of stresses. This paper presents the procedure followed in a welded specimen and to assess the prevailing stresses in a welded specimen using a strain rosette. Fundamental equations involved in arriving at the stresses are presented.

Keywords: Residual stresses, Hole drilling technique, ASTM E837-08, Strain rosette, Stress calculation.

1. INTRODUCTION

In many manufactured engineering components, residual stress is a serious problem affecting accepted stress levels. Residual stress is a “locked-in” stress present within the material independent of external load. Manufacturing process influences residual stress such as welding, casting, rolling, heat treatment, forging. In welding, residual stresses occur due to phase change, thermal cycles, solidification, shrinkage and also due to large temperature difference in HAZ (Heat Affected Zone). The two major factors that influence the stresses in welded parts are the geometry and stiffness of the parts[1]. In order to get some insight in to these serious stress situations, we measured the strains in a welded specimen after following the ASTM standard to ascertain the stress levels. The method of calculating the conversion equation from strain to stress values is presented in this paper.

2. EXPERIMENTAL PROCEDURE

The mechanism that works in a hole drilling method is when the component containing residual stresses is cut in some way, the stresses with force components acting on the cut surface will relieve and the stresses within the remaining material will redistribute to maintain interior force equilibrium[2]. Drilling a hole in a localized area can also release the stress which cause

strain on surface of the component. Drilled hole should not alter the properties of component. With this objective

the hole drilling method was carried out in a welded specimen of flat plate of material SS 304.

2.1 STRAIN ROSETTE

A strain gage rosette is an arrangement of two or more closely positioned gauge grids, separately oriented to measure the normal strains along different directions on the surface of the specimen. Strain gauge works on the principle that small changes in the gauge length of the conductor that are caused by a load applied to the test object induce small changes in the resistance of the conductor. These changes in the gauge resistance are detected by the measuring instrumentation. Main role to be played by strain gauge is to establish strong thin bond with the surface of the specimen so that it can obtain even small surface deformations caused by a hole-drilling process. There are three standard rosette types are used, and the arrangements of these types are shown in Figure 3 as Type A, Type B and Type C[3]. Marking for hole drilling location is indicated at the centre location of the rosettes.

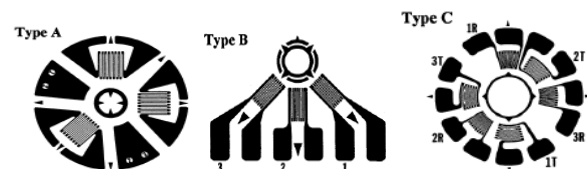

Figure.1

2.2 STRAIN GAUGE INSTALLATION

Strain data is fixed firmly on the test specimen using suitable adhesive. Cyanoacrylate based adhesives are most widely used[4]. Short lead wires are used to avoid lead wire resistance. These lead wires are connected to the data acquisition equipment to read the experimental data.

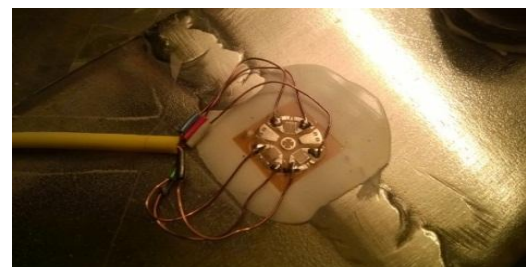

Figure.2

Interval of depth to be drilled is followed with reference to ASTM E837-08. Strain data is recorded at regular interval from three channel of strain rosette. It represents strain along corresponding direction[5]. Type A strain gauge was used to measure strains at three different angles. The installed strain rosette is shown in Figure.2. Strain measurements were carried out at the centre of weld.

3. HOLE DRILLING APPARATUS AND DRILLING METHOD

The hole drilling apparatus is locked using locking nuts [5]. The test specimen was also clamped and the drilling location was adjusted through the eye piece position as shown in Figure 3. At this locked position the eye piece is replaced and in this alignment the air turbine assembly is fixed as shown in Figure 4 [6]. Now, the drilling operation is carried out at the centre of the strain gauge rosette using air turbine capable of operating the drill at a speed of around 40,000 rpm. Micro meter scale is used to control the depth of the drill provided the screw for adjustment. Hole is drilled at regular interval of depth [7]. The interval of depth to be drilled is followed with reference to ASTM E837-08. Locking collar is used to hold the drill. Strain data is recorded at regular interval of depth from three channel of strain rosette. It represents strain along corresponding direction [8]. From each channel of the rosette, the strain was acquired using data acquisition device. The acquired strain is used to calculate the stress values[9].

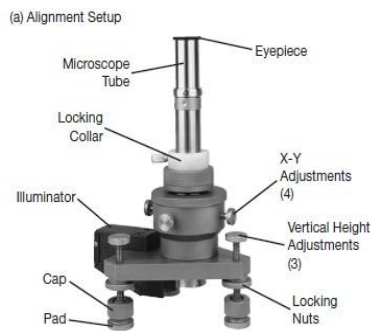

Figure.3

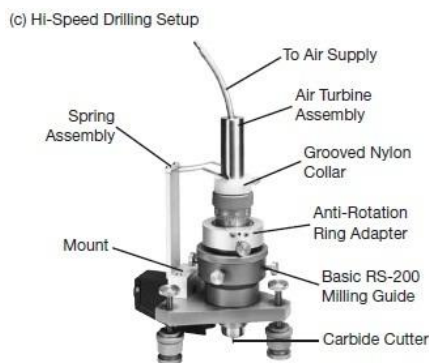

Figure.4

4. CALCULATION OF RESIDUAL STRESSES

The typical arrangement of strain gauges in rosette is used to measure the three normal strains ϵ_A , ϵ_B and ϵ_C is shown in Figure 5. The rosette used to measure normal strains along the x and y axes. It may be noted that the strain components ϵ_x , ϵ_y and γ_{xy} at the measuring point is obtained from the normal strain measurements made along any three lines drawn through the measured point. In our case the measured strains are ϵ_A , ϵ_B and ϵ_C .

Typically α_A , α_B and α_C are the angles forms with the x axis. It is convenient to align strain A with x axis so that $\alpha_A = 0$. This makes the computation simple. The ϵ_A , ϵ_B and ϵ_C are the corresponding strain measurements made from the strain gauges as shown in Figure.5. The relationship between the measured strains and the strains in the x and y axis are written from the strains transformation equation as [8],

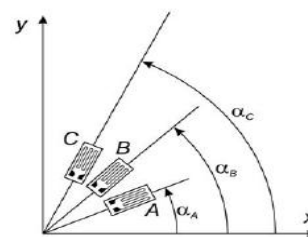

Figure.5

The following transformation relations for strain gauges ϵ_A , ϵ_B and ϵ_C respectively:

$$\epsilon_A = \epsilon_x \cos^2 \alpha_A + \epsilon_y \sin^2 \alpha_A + \gamma_{xy} \sin \alpha_A \cos \alpha_A$$

$$\epsilon_B = \epsilon_x \cos^2 \alpha_B + \epsilon_y \sin^2 \alpha_B + \gamma_{xy} \sin \alpha_B \cos \alpha_B$$

$$\epsilon_C = \epsilon_x \cos^2 \alpha_C + \epsilon_y \sin^2 \alpha_C + \gamma_{xy} \sin \alpha_C \cos \alpha_C$$

The Cartesian components of strain ϵ_x , ϵ_y and γ_{xy} can be determined from the simultaneous solution of above equations. The principal strains are determined by using following equations (1) & (2)

$$\epsilon_1 = \frac{1}{2}(\epsilon_x + \epsilon_y) + \frac{1}{2}\sqrt{(\epsilon_x - \epsilon_y)^2 + \gamma_{xy}^2} \dots\dots\dots (1)$$

$$\epsilon_2 = \frac{1}{2}(\epsilon_x + \epsilon_y) - \frac{1}{2}\sqrt{(\epsilon_x - \epsilon_y)^2 + \gamma_{xy}^2} \dots\dots\dots (2)$$

$$\tan 2\theta = \frac{\gamma_{xy}}{\epsilon_x - \epsilon_y} \quad \text{----- (3)}$$

Two values for the angle θ , these are θ_1 which refers to the angle between the x -axis and the axis of the maximum principal strain ϵ_1 , and θ_2 which is the angle between the x -axis and the axis of the minimum principal strain ϵ_2 is calculated from the equation (3).

$$\sigma_1 = \frac{E}{(1-\nu^2)}(\epsilon_1 + \nu\epsilon_2) \quad \text{----- (4)}$$

$$\sigma_2 = \frac{E}{(1-\nu^2)}(\epsilon_2 + \nu\epsilon_1) \quad \text{----- (5)}$$

The principal stresses are calculated from the above principal strains by the above equations. Thus residual stress incorporated with the specimen is determined using above suggested calculation method[10].

5. CONCLUSION

It is observed from the above investigation that hole-drilling method is straight forward in calculating the residual stress from strain transformation equations. The maximum principal stress obtained in the vicinity of top layer is 1694 MPa (tensile) and the minimum principal stress is 105 MPa (Compressive). To validate these values the simulation of this model is also being carried out using the finite element software ANSYS. May be noted that both the ANSYS and hole drilling method are not considering the effect of melting, Phase change at the HAZ and the micro structural effects. More detailed measurement of stresses is also being planned in the perpendicular direction to the weld.

REFERENCES

- [1]R.S.Parmar, Welding Engineering and Technology, KhannaPublishers (2013)
- [2]American Society for Testing and Materials,Determining Residual Stresses By The Hole-Drilling Strain-Gauge Method.standard test method E837-08, West Conshohocken, PA (2008).
- [3]F A Kandil, J D Lord, A T Fry and P V Grant, A Review of Residual Stress Measurement Methods,NPL Materials Centre (2001).
- [4]SINT Technology,System for Measuring Residual Stress By The Hole-Drilling Method (1998).
- [5]M.N. James,Residual Stress Influences In Mechanical Engineering,CongresoNacional de IngenieríaMecánica (2010).
- [6]N.S. Rossini,Methods of Measuring Residual Stresses In Components, Elsevier Journal (2011).

[7]Gary S. Schajer,Advances In Hole-Drilling Residual Stress Measurements, Proceedings of the XIth International Congress and Exposition (2008).

[8]M. Jeyakumar, Residual Stress Evaluation on Butt-Welded In718 Plates, Canadian Journal of Basic and Applied Sciences (2013)

[9]Experimental Stress Analysis- Strain Gauge Selection, Lecture No. # 36, Department of Applied Mechanics, Indian Institute of Technology, Madras (2006).

[10]Micro Measurements, Measurement of Residual Stresses by the Hole-Drilling- Strain Gauge Method, Tech Note TN-503, (2010)