

# Landfill Monitoring System for Detection of Hazardous Gases

Ms. Shruti Nair<sup>1</sup>, Ms. Siddhi Pota<sup>2</sup>, Prof. Mrs. Jyoti Wadmare<sup>3</sup>

<sup>1</sup> Ms. Shruti Nair, Student, Final Year Computer Engineering, K.J Somaiya Institute of Engineering and IT, Mumbai

<sup>2</sup> Ms. Siddhi Pota, Student, Final Year Computer Engineering, K.J Somaiya Institute of Engineering and IT, Mumbai

<sup>3</sup> Prof. Mrs. Jyoti Wadmare, Dept. of Computer, K.J Somaiya Institute of Engineering and IT, Mumbai

**Abstract** - This paper, proposes an Arduino and Android based system to continuously monitor the air quality of a garbage landfill. When large amount of unsegregated garbage is dumped in the landfill without proper neutralization measures, certain bio chemical reactions take place which result into harmful gaseous effluents. These harmful gases if not detected in due course then it may result in hazardous consequences like interminable uncontrolled fire, suffocation and air congestion in nearby areas, smog etc. In existing scenario air quality monitoring deployment does exist but has portability and scalability constraint. In this proposed system, it consists of an intelligent as emission monitoring system which senses the gases from the landfill. These gas sensors are mounted upon a mobile android controlled robotic vehicle. This system will detect the hazardous gaseous effluents from the garbage dump and if found to be alarmingly high, then it raises an alarm and alerts the master using android application which will be on a mobile phone device. This whole system is controlled by an android user interface which includes navigation of vehicle, providing locations of gaseous effluents and sending alert to the master. Hence this system will prove to be an alternative to large deployments besides human and animal teams engaged in landfill monitoring.

**Keywords:** Arduino, mobile vehicle, sensor, methane, MQ2, landfill etc.

## INTRODUCTION

Environmental monitoring is vital to protect the living beings and the environment from toxic effluents or hazardous airborne chemicals. Air monitoring in a garbage Landfill is tedious and a highly labor-intensive activity and often puts the animal monitoring and human teams at a higher risk while in a dangerously polluted environment. It is therefore very important to identify alternative cost effective measures that will help reduce the impact of pollutants on neighboring environment. When a potentially hazardous airborne chemical effluent is detected, whether its origin is from an accidental industrial leak or from a garbage landfill, it is very important to take necessary containment measures to avoid harm to the surrounding environment. In an effluent polluted environment, locating the source of the gaseous component can be very difficult, especially if it is released from an active source. In such a case, detecting the source and its neutralization becomes the utmost priority. In such a dangerously polluted area, the use of animal teams is inhuman and not advised. Human monitoring teams with

hazard suits and detection devices may locate the gas effluent source efficiently, given appropriate time, but the risk of inflammable or explosive chemicals puts them to a high risk. The use of automated robotic teams working as mobile sensor networks is an alternative way. Wireless sensor networks are novel monitoring tools for a small scale monitoring procedure. A wireless network is created and a large number of tiny sensor nodes can be deployed to a monitoring area.[1] Inexpensive simple and replaceable mobile robotic units can be deployed in the area of the landfill to trace the chemical's odor plume, finding its source and avoiding any additional risk to human or animal lives. These Advanced robotic and measurement technologies have been largely applied for the need of mobility and autonomy of the environmental monitoring.[3]

## II. Existing System

Landfill gas monitoring is a very essential process by which gases that are effluent out from landfills are measured and monitored by electronic systems. Landfill gas is measured when it escapes the landfill. This scenario is called as "Surface Monitoring [10]. In primitive methods to conduct and measure adequate screening, monitoring for garbage landfills, be it with or without monitoring systems,[17] the following hardware and equipments are often used:

1. Combustible gas indicator (CGI), properly calibrated infrared detector flame ionization detector (FID), or an equivalent instrument capable of detecting methane gas at concentrations of 0.5-100.0 percent by volume in air.
2. Assorted connectors and Plastic tubing for ensuring that the connections are airtight when looking up the monitoring instrument to probes.
3. Auxiliary air pump (AP).
4. Tedlar bags or stainless steel summa canisters.
5. Evacuation chamber
6. Magnehelix [11].

To conduct timely checks on the gaseous effluents from the land pits, the human along with the animal team, with sensing equipments are sent to the field which is hazardous as well as non efficient practice. This also makes the process lengthy and expensive. There is also need for constant maintenance when there is such a huge setup. There is a need to automate all the devices and techniques used in

monitoring the gases thus eliminating the need of human and animal teams to venture into the sea of hazards.[6]



Fig. 1 Non portable and wired systems in use

### III. PROPOSED SYSTEM

The ultimate purpose of the proposed system is to automate and regulate the entire process of measuring the gaseous effluent levels of the landfill gases emitted from the pit. It is a known fact that the garbage which has been dumped into the landfill is not properly segregated. Industrial waste, Domestic waste and sometimes even medical waste is dumped into the landfill without undertaking any proper neutralization measures. As a result, when the waste decomposes and decays, biochemical reactions take place which form various gases. Some of these gases are very hazardous and unfit for the human environment. If not detected on time, these may result into frequent fire breakouts in the garbage dump which is many times difficult to control. It may also cause severe smog in the neighbouring areas along with suffocation and congestion. This system aims at early detection of these types of gases so that proper contentment measures can be taken to neutralize the same.

This system consists of a mobile vehicle and an Android User Interface. This vehicle will be remotely controlled, operated and navigated with the help of the android application which will be handled by the master. The robotic vehicle has an Arduino board mounted on it, along with the sensors and RFID reader. A motor driver is also present on the vehicle to facilitate the driving instructions coded for the vehicle to navigate. This mobile vehicle will be set out in the garbage landfill. As soon as the robot senses the gases which are above the set threshold level, it immediately raises an alarm and sends the gaseous effluent location to the master along with the gas level values through the Android application. This wireless communication is established in between the two systems. One is the device with android environment that runs the Android OS and the second one is the mobile robot with a Bluetooth module attached. On the

Android Interface device, the control system to navigate the vehicle is simple which is coded into the Arduino board and connected to the driver.[8] The application is successfully able to send data and instructions through the Bluetooth module in accordance to the sensors, touch screen, and the application features.

On the other side, in the robotic vehicle, a Bluetooth module is connected to the robot controller that will help navigation of the vehicle. The Bluetooth module HC-05 is a little device designed to transmit data between peripheral devices. In other words, the connectivity is achieved and this little device is able to synchronize the I/O data between the robot and the Android Interface.

#### A. Architecture and pin connections of the proposed system

The proposed system is a valid combination of hardware and software peripherals. On the robotic mobile vehicle there is an Arduino Uno board and sensors (MQ2 etc) mounted atop the chassis of the vehicle. An RFID reader is also mounted upon the vehicle to read the RFID tags when it ventures in to the landfill. There is also a driver component to drive the vehicle using Bluetooth module navigation which is handled using Android. A variety of sensors can be used and which sensor should be mounted would be dependable upon the area where it is being used.

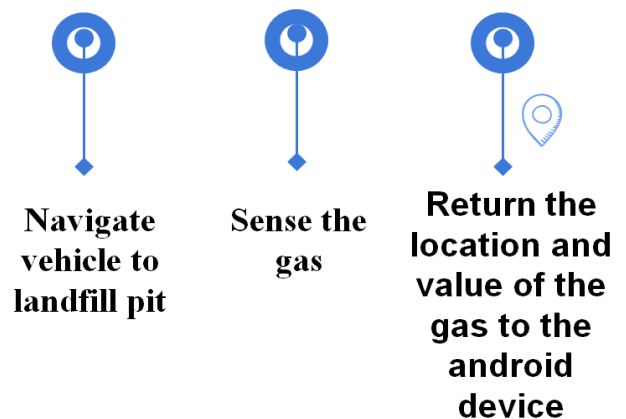

Fig. 2 Overview of the process

The mobile vehicle is navigated and controlled using the android interface. The motor driver is programmed to accept the instructions through the android device. There will also be an RFID card reader along with the Arduino board and sensors. This RFID reader will be useful to return the location details, in the form of grid number wherever the mobile vehicle is moving. The data obtained will also be available for further processing. The power supply given to the entire system will be by 12 volts, 2amperes Lithium ion battery. The pin connections of the entire system are given ahead.

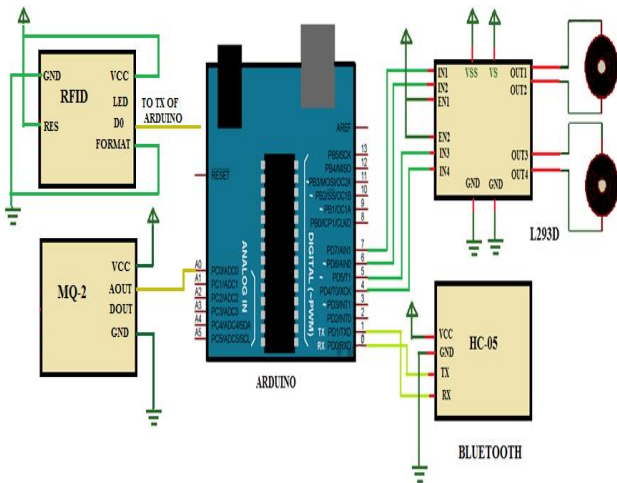

Fig. 3 Pin connections of hardware of mobile vehicle

The overall system will consist of the hardware and software components. The most essential component to achieve connectivity between the hardware and software components is the HC 05 Bluetooth module. HC-05 module is an easy to use Bluetooth SPP (Serial Port Protocol) module, designed for transparent wireless serial connection setup.

Serial port Bluetooth module is an excellently qualified Bluetooth V2.0+EDR (Enhanced Data Rate) 3Mbps Modulation with complete 2.4GHz radio transceiver and baseband. It uses CSR Blue core 04-External single chip Bluetooth system with CMOS technology and with AFH (Adaptive Frequency Hopping Feature). It has the footprint as small as 12.7mmx27mm. [10] Pin Diagram as given below.[17]

HC-05 Connections to Arduino

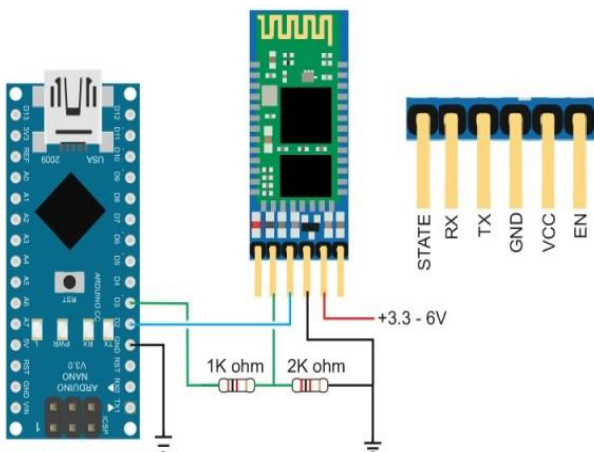

Fig. 4 Pin connection - Bluetooth module and Arduino

B. Air sensing application

Arduino board is an open-source electronics prototyping platform based on easy-to-use, flexible, software and hardware. Arduino board is capable perceiving the environment by receiving input from a variety of sensor (MQ2 Series) and can process according to the surroundings by controlling motors, lights, and other actuators. Arduino projects are stand-alone or they can communicate with software running on a computer [3]. There are various AVR series of Arduino controls available and here the proposed system prototype uses Arduino Uno microcontroller. For example MQ-2 gas sensor is used to detect various gas densities in air.

Technical Data

Model No.		MQ-2
Sensor Type		Semiconductor
Standard Encapsulation		Bakelite (Black Bakelite)
Detection Gas		Combustible gas and smoke
Concentration		300-10000ppm ( Combustible gas)
Circuit	Loop Voltage	V <sub>c</sub> ≤24V DC
	Heater Voltage	V <sub>H</sub> 5.0V±0.2V AC or DC
	Load Resistance	R <sub>L</sub> Adjustable
Character	Heater Resistance	R <sub>H</sub> 31Ω±3Ω Room Tem.
	Heater consumption	P <sub>H</sub> ≤900mW
	Sensing Resistance	R <sub>s</sub> 2KΩ-20KΩ(in 2000ppm C <sub>3</sub> H <sub>8</sub> )
	Sensitivity	S R <sub>s</sub> (in air)/R <sub>s</sub> (1000ppm isobutane) ≥5
	Slope	α ≤0.6(R5000ppm/R3000ppm CH <sub>4</sub> )
Condition	Tem. Humidity	20±265%±5%RH
	Standard test circuit	V <sub>c</sub> :5.0V±0.1V V <sub>H</sub> : 5.0V±0.1V
	Preheat time	Over 48 hours

Table: Sensor MQ-2 specification

Sensors to be used in the actual proposed system will be area specific. The MQ series of gas sensors use a small heater inside with an electro-chemical sensor. They are sensitive for a range of gasses. They can be calibrated more or less (see the section about "Load-resistor" and "Burn-in") but a know concentration of the measured gas or gasses is needed for that. The output is an analog signal and can be read with an analog input of the Arduino. MQ-4 sensor has detecting concentration scope: 200-10000ppm CH<sub>4</sub> and natural gas. The standard detecting condition is Temp: 20 degree Celsius and V<sub>c</sub>: 5V±0.1, Humidity: 65%±5% V<sub>H</sub>: 5V±0.1.[9]

A simple circuit is formed to connect sensor to Arduino. The program is written in the Arduino IDE. The language used is like embedded C for Arduino programming. The results obtained can be displayed effectively in the android application using pie chart, bar graph or any other data interpretation technique. A landfill gases contains the following gases: Methane, nitrogen, carbon dioxide, oxygen, moisture, other trace species etc. [4]



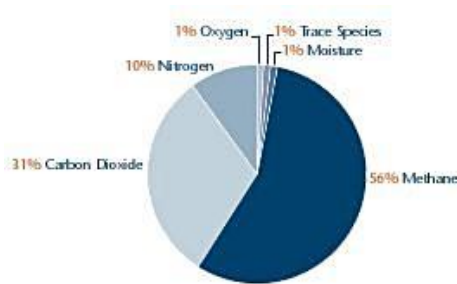

Fig. 5 Contents of a landfill effluent gas

The major component of the landfill effluent gases is methane. For prototyping of this project the MQ2 gas sensor is used. This gas sensor measures gas densities of smoke, propane, LPG etc. Hence for further deployment different types of sensors can be used depending upon the nature of environment and surroundings where it is used.[17]

Expected result for Sensor Data is given below. For the prototyping purpose the ALERT threshold is set to 170. Any value above 170 will show a gas alert in that area. These values will get stored in the text file and will remain available for further processing.

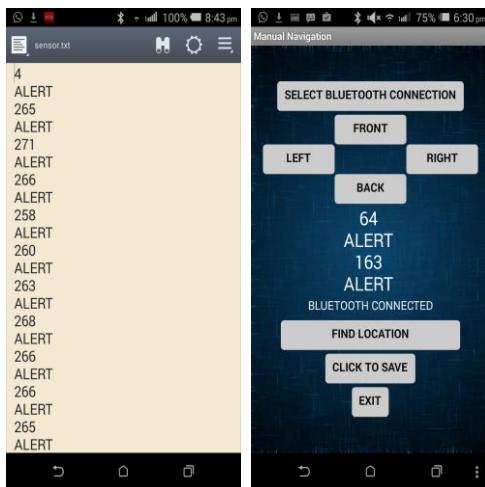

Fig. 6 Sensor Values on Display



Fig. 7 RFID Working

### C. RFID for specifying location

RFID is an acronym for Radio-Frequency Identification. This acronym means to small electronic components that consist of a small antenna and a chip. The chip traditionally is capable of carrying around 2 Kilo bytes of data or maybe even less sometimes. It provides it with a unique identifier for that object. It is just as simple as a bar code or a magnetic strip that is scanned to get the information and the RFID device must be simultaneously scanned to retrieve the identifying information for the same.[5]An RFID reader is used to read RFID tags (which contain certain unique data stored in a chip). An RFID reader and an RFID tag, both have

### D. Android application development

This is the final step of the proposed project where the movement of the robot is controlled by the Android application and the data is received. Android is a very well known open source mobile operating system based on Linux platform and it is the first truly open and complete mobile software for mobile terminal. In order to solve the demerits of the traditional surveying system, this project proposed a surveillance scheme based on android smart phone, which makes it possible to monitor target site in anywhere and anytime via android smart phone under the coverage of

wireless network. [6] To develop it we use the eclipse for coding (java) and Android SDK for development of the apps. In this we write two set of coding. One is Bluetooth adapter coding to connect Bluetooth shield with mobile Bluetooth. And next is sending commands to the Robot to move in user desired direction. [7]

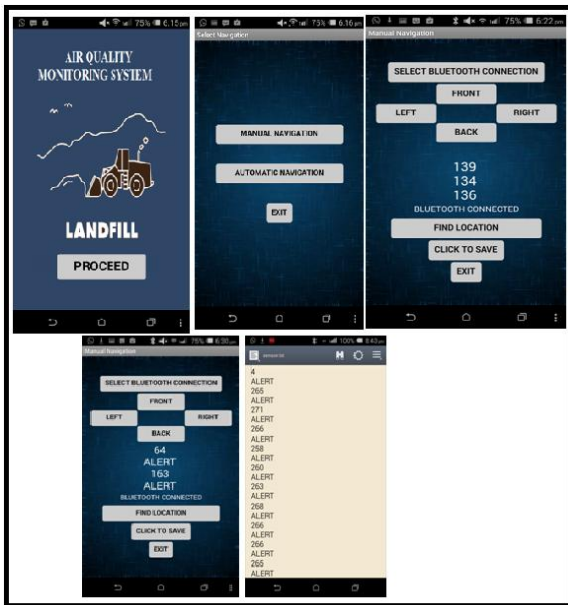

Fig. 8 Representation of the UI in Android

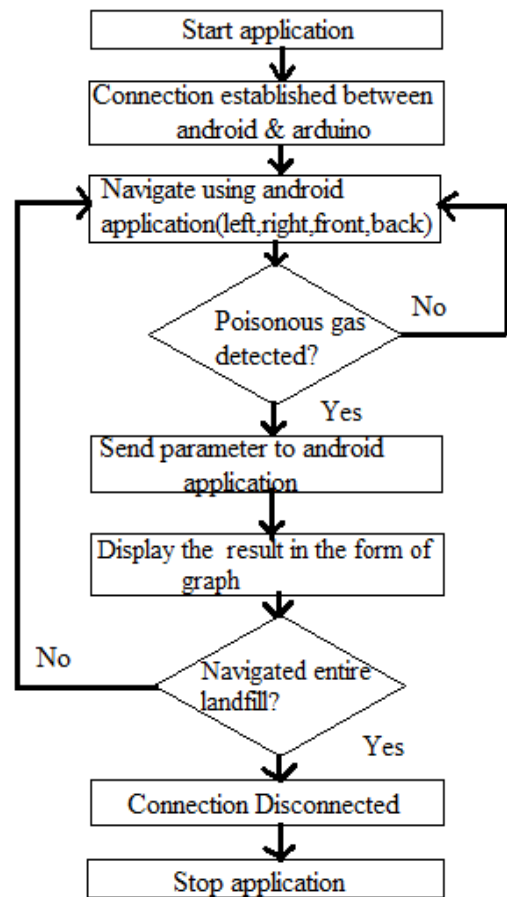

Fig. 9 Flow of the system operation

**E. System Flow**

The android application controlled robot communicates via Bluetooth to the Bluetooth module present on the robot. While pressing each button on the application, corresponding commands are sent via Bluetooth to the robot. The commands that are sent are in the form of ASCII. The Arduino on the robot then checks the command received with its previously defined commands and controls the servo motors depending on the command received to cause it to move forward, backward, left, right or to stop, thus allowing us to create an android controlled robot. [16]The sensors then sense the gases around in the surrounding and give live updated values to the master through the android UI along with the location. If the gaseous effluents are found to be harmful and above the permissible level the mobile vehicle sends back the alert message to the master with the location of the gas. If no threat detected then the mobile robotic vehicle will move ahead into the next desired sector and repeat all the steps. The gaseous values will constantly be updated. The diagrammatic representation of the above discussion is shown in the adjacent fig 4. The values obtained from the sensor will also be stored in a text file. This file can be used for further analysis and future predictions about the gaseous effluents.

**IV. Conclusion**

Anaerobic decomposition of organic solid waste in the landfill site produces landfill gas (LFG). LFG mainly consists of methane and carbon dioxide, both of which are odorless. Trace constituents of other volatiles, often malodorous or toxic gases, are also found in LFG. LFG can migrate through soil into structures located on or near landfills. Since methane presents a fire or explosive threat, LFG must be controlled to protect property, public health and safety. There are also E.A. requirements of landfill owners/operators to reduce reactive organic gas emissions to improve air quality. Thus, engineered solutions are needed to efficiently and safely monitor, collect, and process landfill gas. In this paper an automated air monitoring system is explained which is controlled by the Android operating system. The hardware and software components are connected to each other via Bluetooth. The navigation of the vehicle is also done with the help of Android user interface. The mobile vehicle which will have all the hardware components mounted on it, will venture into the landfill area after sensing the gases will send real time values

to the android device operated by the master. This project addresses the overall problem of harmful gaseous emissions from the pits of garbage dump. This project aims to facilitate the monitoring of air quality in and around the landfill areas where chemical waste along with domestic waste is dumped. This project will be area specific. This paper proposes an overall effective solution for the need of elimination of the animal and human teams into coming in contact with the hazardous environment. [16]

#### ACKNOWLEDGMENT

The project team wholeheartedly would like to thank the Head of Department and staff of Computer Department, K.J. Somaiya Institute of Engineering and IT for their support and cooperation into nurturing of this idea. The team would also like to express gratitude to all the well wishers and experts who have guided us during the formulation of this project proposal and prototyping.

#### REFERENCES

- [1] Application of a reliable MAC protocol for the urban air quality monitoring system based on the wireless sensor network, Tzu-Shiang Lin March 2012, Orlando, FL.
- [2] Sensor-based Emissions Monitoring System, In Chae Jeong, Oct. 2012, Taipei.
- [3] Maik Schmidt: e-book "Arduino – A Quick start guide", Pragmatic Programmers, LLC, 2011.
- [4] Contents of Landfill gas  
<http://greenfieldtechnical.com/resources/flare2.jp>
- [5] Non portable equipments to measure gas levels  
<http://www.vanwalt.com/rental-meters.htm>
- [6] RFID definitions  
<http://www.technovelgy.com/ct/technology-article.asp>
- [7] Mobile Robot Temperature Monitoring System Controlled by Android Application via Bluetooth: Maria Jenifer, T. S. Vasumathi Priyadharshini, Raja Lavanya & S. Raj Pandian.
- [8] Android based Remote monitoring System, Abhishek Barve Department of Electronic Engineering PIIT, New Panvel, Pragnesh shah Department of Electronic Engineering PIIT, New Panvel.
- [9] A New Architecture of Robotic Sensor Networks for Air Quality Monitoring, Ade Silvia, NyayuLatifahHusni, and SitiNurmaini.
- [10] Bluetooth Module Description :  
[1] [http://wiki.iteadstudio.com/Serial\\_Port\\_Bluetooth\\_Module\\_%28Master/Slave%29:\\_HC-05](http://wiki.iteadstudio.com/Serial_Port_Bluetooth_Module_%28Master/Slave%29:_HC-05)
- [11] The Robot control using the wireless communication and the serial communication, JONG HOON AHNN
- [12] Landfill Gas Monitoring information:  
[https://en.wikipedia.org/wiki/Landfill\\_gas\\_monitoring](https://en.wikipedia.org/wiki/Landfill_gas_monitoring)
- [13] Landfill monitoring procedures:  
<http://www.cce.csus.edu/sites/Calrecycle/leaLandfil>

lGas/docs/2\_Landfill\_Gas\_Monitoring\_Procedures.pdf

- [14] L293D Motor Driver IC:  
<http://www.rakeshmondal.info/L293D-Motor>
- [15] Omicron Labs: <https://www.omicron-lab.com>
- [16] Air quality monitoring using android controlled robot in a garbage landfill.  
[www.ijetee.org/Docs/Volume%2011/Issue%205/17.pdf](http://www.ijetee.org/Docs/Volume%2011/Issue%205/17.pdf)
- [17] Images source: Google images