

## TWO WHEELER DRIVEN BY COMPRESSED AIR

N.Prithiviraj<sup>1</sup>, M.Munikrishnan<sup>2</sup>, N.Nandhakumar<sup>2</sup>, S.Prem Ananth<sup>2</sup>

<sup>1</sup> PG Scholar, Department of Mechanical Engineering Gnanamani College of Technology, Mechanical Engineering, India

<sup>2</sup> UG Scholar, Department of Mechanical Engineering Gnanamani College of Technology, Mechanical Engineering, India

\*\*\*

**Abstract** - The project paper describes the working of Engine which can run on pneumatic power as by compressed air. Since, it is an old technique which can attract many scientist as well as Engineer's for many years. This paper describes on the same with some new modification which is main objective of this research paper. Since engine is operated by Compressed air which contribute to reduce the air pollution and tend to zero pollution level of atmosphere and making a great an environment. There is no mixing of fuel with air as there is no combustion.

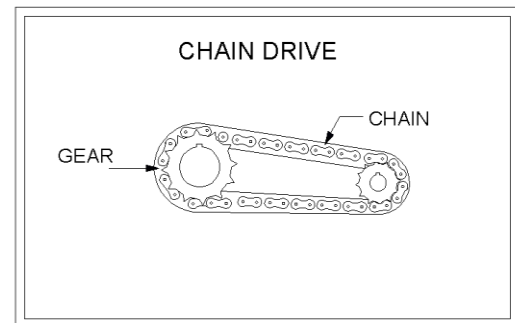

Figure.1. Chain drive

**Key Words:** Air Compressor, Engine, Gate Valve, Pollution, Environment

### 1. INTRODUCTION

A compressed-air vehicle is powered by an AIR OPERATED FOUR WHEELER, using compressed air, which is stored in a tank. Instead of mixing fuel with air and burning it in the engine to drive pistons with hot expanding gases, compressed air vehicles (CAV) use the expansion of compressed air to drive their pistons. Compressed air propulsion may also be incorporated in hybrid systems, e.g., battery electric propulsion and fuel tanks to recharge the batteries. This kind of system is called hybrid-pneumatic electric propulsion.

### 2. CHAIN DRIVE

mechanical power from one place to another. It is often used to convey power to the wheels of a vehicle, particularly bicycles and motorcycles. It is also used in a wide variety of machines besides vehicles. The power is conveyed by a roller chain, known as the drive chain, passing over a sprocket gear, with the teeth of the gear meshing with the holes in the links of the chain. The gear is turned, and this pulls the chain putting mechanical force.



Figure.2. 3D-Chain drive

### 3.4. Engine

A four-stroke engine is an internal combustion engine in which the piston completes four separate strokes while turning a crankshaft. A stroke refers to the full travel of the piston along the cylinder, in either direction. The four separate strokes are termed:

- Intake: This stroke of the piston begins at top dead center (T.D.C.) and ends at bottom dead center (B.D.C.). In this stroke the intake valve must be in the open position while the piston pulls an air-fuel mixture into the cylinder by producing vacuum pressure into the cylinder through its downward motion.
- Compression: This stroke begins at B.D.C, or just at the end of the suction stroke, and ends at T.D.C. In this stroke the piston compresses the air-fuel mixture in preparation for ignition during the power stroke (below). Both the intake and exhaust valves are closed during this stage.
- Power: This is the start of the second revolution of the four stroke cycle. At this point the crankshaft has completed a full 360 degree revolution. While the piston is at T.D.C. (the end of the compression stroke) the compressed air-fuel mixture is ignited by a spark plug (in a gasoline engine) or by heat generated by high compression (diesel engines), forcefully returning the piston to B.D.C. This stroke produces mechanical work from the engine to turn the crankshaft.
- Exhaust: During the *exhaust* stroke, the piston once again returns from B.D.C. to T.D.C. while the exhaust valve is open. This action expels the spent air-fuel mixture through the exhaust valve.

The problem with compressed charge engines is that the temperature rise of the compressed charge can cause pre-ignition. If this occurs at the wrong time and is too energetic, it can damage the engine. Different fractions of petroleum have widely varying flash points (the temperatures at which the fuel may self-ignite). This must be taken into account in engine and fuel design. The tendency for the compressed fuel mixture to ignite early is limited by the chemical composition of the fuel. There are several grades of fuel to accommodate differing performance levels of engines. The fuel is altered to change its self ignition temperature. There are several ways to do this. As engines are designed with higher compression ratios the result is that pre-ignition is much more likely to occur since the fuel mixture is compressed to a higher temperature prior to deliberate ignition. The higher temperature more effectively evaporates fuels such as gasoline, which increases the efficiency of the compression engine. Higher Compression ratios also mean that the distance that the piston can push to produce power is greater (which is called the Expansion ratio).

The octane rating of a given fuel is a measure of the fuel's resistance to self-ignition. A fuel with a higher numerical octane rating allows for a higher compression

ratio, which extracts more energy from the fuel and more effectively converts that energy into useful work while at the same time preventing engine damage from pre-ignition. High Octane fuel is also more expensive. Diesel engines by their nature do not have concerns with pre-ignition.

They have a concern with whether or not combustion can be started. The description of how likely Diesel fuel is to ignite is called the Cetane rating. Because Diesel fuels are of low volatility, they can be very hard to start when cold. Various techniques are used to start a cold Diesel engine, the most common being the use of a glow plug.

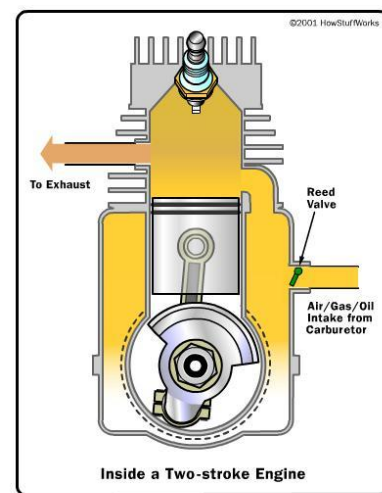

Figure.3. Engine

The maximum amount of power generated by an engine is determined by the maximum amount of air ingested. The amount of power generated by a piston engine is related to its size (cylinder volume), whether it is a two-stroke or four-stroke design, volumetric efficiency, losses, air-to-fuel ratio, the calorific value of the fuel, oxygen content of the air and speed (RPM). The speed is ultimately limited by material strength and lubrication. Valves, pistons and connecting rods suffer severe acceleration forces. At high engine speed, physical breakage and piston ring flutter can occur, resulting in power loss or even engine destruction. Piston ring flutter occurs when the rings oscillate vertically within the piston grooves they reside in. Ring flutter compromises the seal between the ring and the cylinder wall, which causes a loss of cylinder pressure and power. If an engine spins too quickly, valve springs cannot act quickly enough to close the valves. This is commonly referred to as 'valve float', and it can result in piston to valve contact, severely damaging the engine. At high speeds the lubrication of piston cylinder wall interface tends to

break down. This limits the piston speed for industrial engines to about 10 m/s.

### 3.5. Gate Valve

Gate valve, also known as a sluice valve, is a valve that opens by lifting a round or rectangular gate/wedge out of the path of the fluid. The distinct feature of a gate valve is the sealing surfaces between the gate and seats are planar, so gate valves are often used when a straight-line flow of fluid and minimum restriction is desired. The gate faces can form a wedge shape or they can be parallel. Gate valves are primarily used to permit or prevent the flow of liquids, but typical gate valves shouldn't be used for regulating flow, unless they are specifically designed for that purpose. Because of their ability to cut through liquids, gate valves are often used in the petroleum industry. For extremely thick fluids, a specialty valve often known as a knife valve is used to cut through the liquid.



Figure.5. 3D-Gate valve

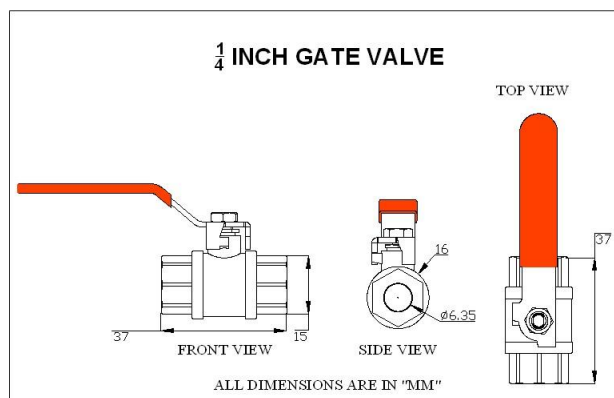

Figure.4. gate valve

On opening the gate valve, the flow path is enlarged in a highly nonlinear manner with respect to percent of opening. This means that flow rate does not change evenly with stem travel. Also, a partially open gate disk tends to vibrate from the fluid flow. Most of the flow change occurs near shutoff with a relatively high fluid velocity causing disk and seat wear and eventual leakage if used to regulate flow. Typical gate valves are designed to be fully opened or closed. When fully open, the typical gate valve has no obstruction in the flow path, resulting in very low friction loss. Gate valves are characterized as having either a rising or a non rising stem. Rising stems provide a visual indication of valve position because the stem is attached to the gate such that the gate and stem rise and lower together as the valve is operated.

Non rising stem valves may have a pointer threaded onto the upper end of the stem to indicate valve position, since the gate travels up or down the stem on the threads without raising or lowering the stem. Non rising stems are used underground or where vertical space is limited.



Bonnets provide leak proof closure for the valve body. Gate valves may have a screw-in, union, or bolted bonnet. Screw-in bonnet is the simplest, offering a durable, pressure-tight seal. Union bonnet is suitable for applications requiring frequent inspection and cleaning. It also gives the body added strength. Bolted bonnet is used for larger valves and higher pressure applications.

Another type of bonnet construction in a gate valve is pressure seal bonnet. This construction is adopted for valves for high pressure service, typically in excess of 2250 psi (15 MPa). The unique feature about the pressure seal bonnet is that the body-bonnet joint seal improves as the internal pressure in the valve increases, compared to other constructions where the increase in internal pressure tends to create leaks in the body-bonnet joint. Gate valves may have flanged ends which are drilled according to pipeline compatible flange dimensional standards. Gate valves are typically



constructed from cast iron, ductile iron, cast carbon steel, gun metal, stainless steel, alloy steels, and forged steels.

### 3.6. Air Tank

Storage can be used to control demand events (peak demand periods) in a compressed air system by reducing both the amount of pressure drop and the rate of decay. Storage can be used to protect critical pressure applications from other events in the system. Storage can also be used to control the rate of pressure drop in demand while supporting the speed of transmission response from supply. For some systems, it is important to provide a form of refill control such as a flow control valve. Many systems have a compressor operating in modulation to support demand events, and sometimes strategic storage solutions can allow for this compressor to be turned off.

Air tank is a container designed to hold gases or liquids at a pressure substantially different from the ambient pressure. The pressure differential is dangerous, and fatal accidents have occurred in the history of pressure vessel development and operation. Consequently, pressure vessel design, manufacture, and operation are regulated by engineering authorities backed by legislation. For these reasons, the definition of a pressure vessel varies from country to country, but involves parameters such as maximum safe operating pressure and temperature, and are engineered with a safety factor, corrosion allowance, minimum design temperature (for brittle fracture), and involve nondestructive testing, such as ultrasonic testing, radiography, and pressure tests, usually involving water, also known as a hydro test, but could be pneumatically tested involving air or another gas. The preferred test is hydrostatic testing because it's a much safer method of testing as it releases much less energy if fracture were to occur (water does not rapidly increase its volume while rapid depressurization occurs, unlike gases like air, i.e. gasses fail explosively). In the United States, as with many other countries, it is the law that vessels over a certain size and pressure be built to Code, these vessels also require an Authorized Inspector to sign off on every new vessel constructed and each vessel has a nameplate with pertinent information about the vessel such as maximum allowable working pressure, maximum temperature, minimum design metal temperature.

#### 3.6.1. Air Tank Safety Measures

(a) Each air tank shall be protected by 1 or more safety valves and other indicating and controlling devices that will insure safe operation of the tank. If the tank has a volumetric capacity in excess of 2,000 gallons, it shall be fitted with at least 2 safety valves, the smallest of which shall have a relieving capacity of at least 50 percent of the relieving capacity of the largest valve.

(b) Safety relief valves shall:

- Be constructed and installed in accordance with ASME Boiler and Pressure Vessel Code,
- Be located and installed so that they cannot be readily rendered inoperative.
- No valve of any description shall be placed between the required safety valve or rupture disc and the air tank.
- The opening or connection between the tank and safety valve or valves shall have a cross-sectional area at least equal to the combined areas of all attached safety valve inlets.
- Be of the direct spring-loaded type. The springs shall not be adjusted to carry more than: 10 percent greater pressure than the set pressure stamped on the valve up to and including 250 psig; or 5 percent greater pressure than the set pressure stamped on the valve above 250 psig.
- For pressures of 2000 psig or less safety valves shall be equipped with a substantial lifting device so that the disc can be easily lifted from its seat not less than 1/8 the diameter of the seat when the pressure in the tank is 75 percent of that at which the safety valve is set to open.
- For pressures exceeding 2000 psig: the lifting device may be omitted providing the valve is removed for testing at least once each year and a record kept of this test and made available to the qualified inspector;
- Be set to open at not more than the allowable working pressure of the tank.
- Have a relieving capacity sufficient to prevent a rise of pressure in the tank of more than 10 percent above the allowable working pressure when all connected compressors are operating with all unloading devices rendered inoperative.
- Not have seats or discs of cast iron.
- Be tested frequently and at regular intervals to determine whether they are in good operating condition.

(C) Discharge pipes from safety valves and rupture discs installed on air tanks shall:

- Have a cross-sectional area at least equal to the combined outlet areas of all valves discharging into them.
- Be designed and installed so that there will be no interference with the proper operation or discharge capacity of the safety valve or rupture disc.
- Have no valve of any description.
- Be fitted with open drains which will prevent the accumulation of liquid above the safety valve or rupture disc.
- Be installed and supported in a manner that will prevent undue stresses on the safety valve or rupture disc.
- Be led to a safe place of discharge.
- Each air tank shall be equipped with a suitable pressure indicating gage with the dial graduated to approximately double the operating pressure, but in no case less than 1.2 times the pressure at which the safety-relieving device is set to function.
- Each air tank shall be equipped with a manually operated, valved drain located at the lowest point where water can collect. The valve for this drain shall be suitably located for convenient operation. Automatic drains shall not be considered as complying with this order unless also equipped with a manually operated by-pass.

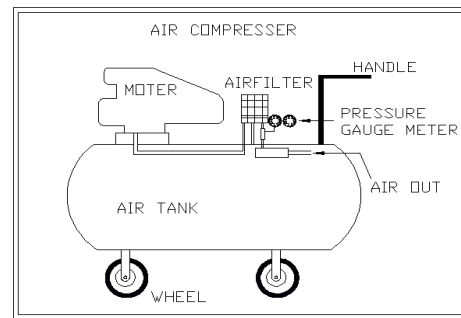

Figure.6. Air compressor

Other chemicals that may have been drawn into the compressor intake may also be present. This contamination is harmful to many processes, pneumatic tools, instruments and equipment. Air purification equipment, filters, air dryers, breathing air purifiers, monitoring equipment, used alone or in combination will remove these contaminants. Selection and purchase of the compressor and necessary purification equipment can be easily done on the Compressed air site. Our application engineers are ready to answer all of your questions and to assist you in placing your order. And it work in the process of rotating the fan and the piston movement with the help of current supply.

### 3.7. AIR COMPRESSOR

Compressor is the air producing machine. They collect the airs from the atmosphere are in the running of machine are engine. Air compressors are utilized to raise the pressure of a volume of air. Air compressors are available in many configurations and will operate over a very wide range of flow rates and pressures. Compressed air was expelled by primitive man to give glowing embers sufficient oxygen to allow them to flare up into a fire. During the compression process, the temperature increases as the pressure increases. This is known as polytypic compression. The amount of compression power also increases as the temperature increases. Compressors are staged thereby reducing the temperature rise and improving the compression efficiency. The temperature of the air leaving each stage is cooled prior to entering the next stage. This cooling process is called inter cooling. Volumetric efficiency also increases with multi-stage compression since the pressure ratio over the first stage will be decreased. Selection of the air compressor is only the first step in designing an efficient and reliable compressed air system. The air exiting the compressor is saturated with moisture and will have compressor lubricants (lubricated compressors only).



Figure.7. 3D-Air compressor

### 3.8. Battery

The battery is the primary source of electrical energy in most of the vehicles. It stores chemicals, not electricity. Two different type of lead in an acid mixture reacts to produce electrical pressure. This electro chemical reaction changes chemical energy into electrical energy.

#### 3.8.1. Factors Affecting Charging:

- Temperature,
- State of charge,
- Plate area,

- Impurities,
- Gassing.

3.9.

an  
that  
direct  
the  
were



Figure.8. Battery

**Dynamo:**

A dynamo is an electrical generator that produces current with use of a commutator. Dynamos were the first electrical generators

capable of delivering power for industry, and the foundation upon which many other later electric-power conversion devices were based, including the electric motor, the alternating-current alternator, and the rotary converter. Today, the simpler alternator dominates large scale power generation, for efficiency, reliability and cost reasons. A dynamo has the disadvantages of a mechanical commutator. Also, converting alternating to direct current using power rectification devices (vacuum tube or more recently solid state) is effective and usually economic.



Figure.9. Dynamo

**CALCULATION AND BLOCK DIAGRAM**

**4.1. Calculation for Chain Drive**

Parameters taken from standard specification of sprocket:

No of teeth on the small sprocket = 14

No of teeth on the large sprocket = 42

Speed of sprocket = 3000 RPM

Outside diameter of the small sprocket  $D_o = 65$  mm

Pitch circle diameter of the small sprocket  $D_p = 60$  mm

To find:

- 1) Terminology used in the chain drive
- 2) Tooth profile of the sprocket
- 3) Velocity ratio, length of the chain
- 4) Power transmitting chains

Solution:

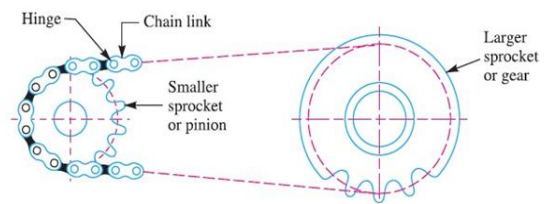

Figure.10. Sprocket

Terminology used in the chain drive

Pitch Circle diameter:

It is the diameter of the pitch circle on which the hinge centre of the chain lie

Here we taken diameter of the pitch circle  $D_p = 60$  mm

Relation between Pitch and Pitch circle diameter:

Considering Pitch length AB of the chain subtending at an angle  $\theta$  at the centre of the sprocket

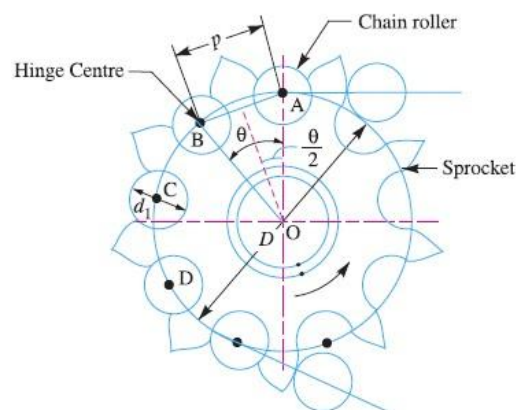

Figure.11. Terminology

$$\theta = \frac{360^\circ}{T}$$

$$= 360 / 14 = 25^\circ$$

$$\text{Pitch of the chain, } p = D_p \sin \frac{180}{T}$$

Diameter of the chain roller  $d_1$

$$= D_p + 0.8d_1$$

$$60 + (0.8 \times d_1)$$

Diameter of the chain,  $d_1 = 6.25 \text{ mm}$

Tooth profile of the Sprocket:

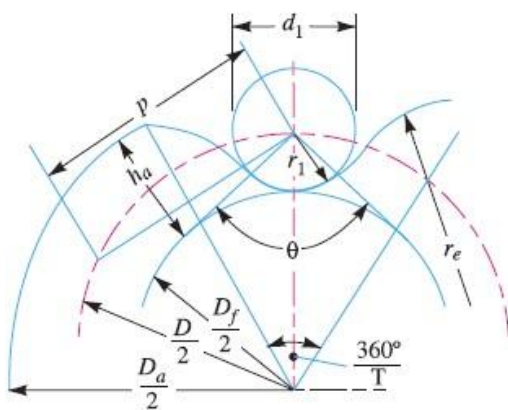

(a) Tooth profile of sprocket.

Figure.12

Tooth flank radius  $r_e$

$$= 0.008 d_1 (T^2 + 180)$$

$$= 0.008 \times 6.25 ((14)^2 + 180)$$

$$= 18.8 \text{ mm}$$

Roll seating radius  $r_1$

$$= 0.505 d_1 + 0.069 \sqrt[3]{(d_1)}$$

$$= (0.505 \times 6.25) + 0.069 \sqrt[3]{(6.25)}$$

$$= 3.28 \text{ mm}$$

Roll seating angle  $\alpha$

$$\text{Maximum roll seating angle} = 140^\circ - 90^\circ / T$$

$$= 140^\circ - 90^\circ / 14$$

$$= 3.57^\circ$$

$$\text{Minimum roll seating angle} = 120^\circ - 90^\circ / T$$

$$= 120^\circ - 90^\circ / 14$$

$$= 2.14^\circ$$

Tooth Height of the above pitch polygon ( $h_a$ )

$$= 0.5 (p - d_1)$$

$$= 0.5(13.35 - 6.25)$$

$$= 3.55 \text{ mm}$$

Root diameter ( $D_f$ ) =  $D_p - 2r_1$

$$= 60 - (2 \times 3.28)$$

$$= 53.44 \text{ mm}$$

Velocity ratio of the chain drives

We know that

$$\text{No of teeth on the small sprocket} = 14$$

$$\text{No of teeth on the large sprocket} = 42$$

$$\text{Speed of the sprocket} = 48\text{RPM}$$

Velocity Ratio

$$N_1 / N_2 = T_2 / T_1$$

$$3000 / N_2 = 42 / 14$$

$$\text{Speed of the large sprocket, } N_2 = 1000 \text{ RPM}$$

$$\text{Average velocity of the chain, } V = \pi D N / 60$$

$$= (3.14 \times 60 \times 3000) / 60$$

$$= 9425 \text{ mm /sec} = 9.425 \text{ m/s}$$

$$= 18891.585 \text{ N}$$

Length of the chain

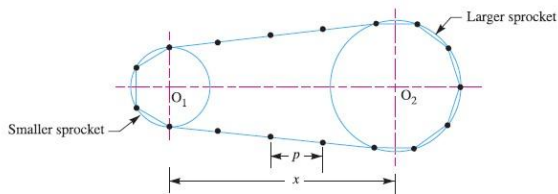

Figure.13. Chain sprocket

Let us

assume

Centre distance between the chain sprocket and chain Driven X = 400 mm

The length of the chain must be equal to product of the number of chain links and pitch of the chain

$$L = k p$$

Number of chain links

$$K = (T_1 + T_2) / 2 + (2X/p) + ((T_2 - T_1) / 2\pi)^2 (p/x)$$

$$K = (14 + 42) / 2 + ((2 \times 400) / 13.35) + ((42 - 14) / 2\pi)^2 (13.35 / 400)$$

$$K = 28 + 59.92 + 0.66 = 88.58$$

Length of the chain

$$L = k \times p$$

$$L = (88.58 \times 13.35) = 1182.5 \text{ mm}$$

$$= 1.1825 \text{ m}$$

Power Transmitted By the Chain:

Factor of safety for chain drives

$$FOS = W_B / W$$

$W_B$  = Breaking strength of the chain

$$W_B = 106 p^2 = 106 \times 13.35 \times 13.35$$

The total load on the driving side of the chain (W)

It is the sum of the tangential driving force ( $F_t$ ) and centrifugal tension in the chain ( $F_c$ ) and tension in the chain due to sagging ( $F_s$ ).

$$W = F_t + F_c + F_s$$

Tangential driving force acting on the chain ( $F_t$ )

$F_t$  = power transmitted / speed of the chain in m/s

Power Transmitted

$$P = 2\pi NT / 60$$

Let us assume shear stress value for mild steel

$$\tau = 110 \text{ N/mm}^2$$

Engine Torque T = 8 N-m

$$P = 2\pi NT / 60$$

$$= (2 \times 3.14 \times 3000 \times 8) / 60 = 2513.27 \text{ watts}$$

Tangential driving force acting on the chain ( $F_t$ )

$$F_t = P / V = 2513.27 / 0.18$$

Let, Velocity of the sprocket

$$V = 0.18 \text{ m/s}$$

$$F_t = 13962.6 \text{ N}$$

Centrifugal tension in the chain

$$(F_c) = m \times v^2$$

$$= (0.53 \times 0.18 \times 0.18)$$

$$= 0.0172 \text{ kg - m/s}^2$$

**4.2. Block Diagram**



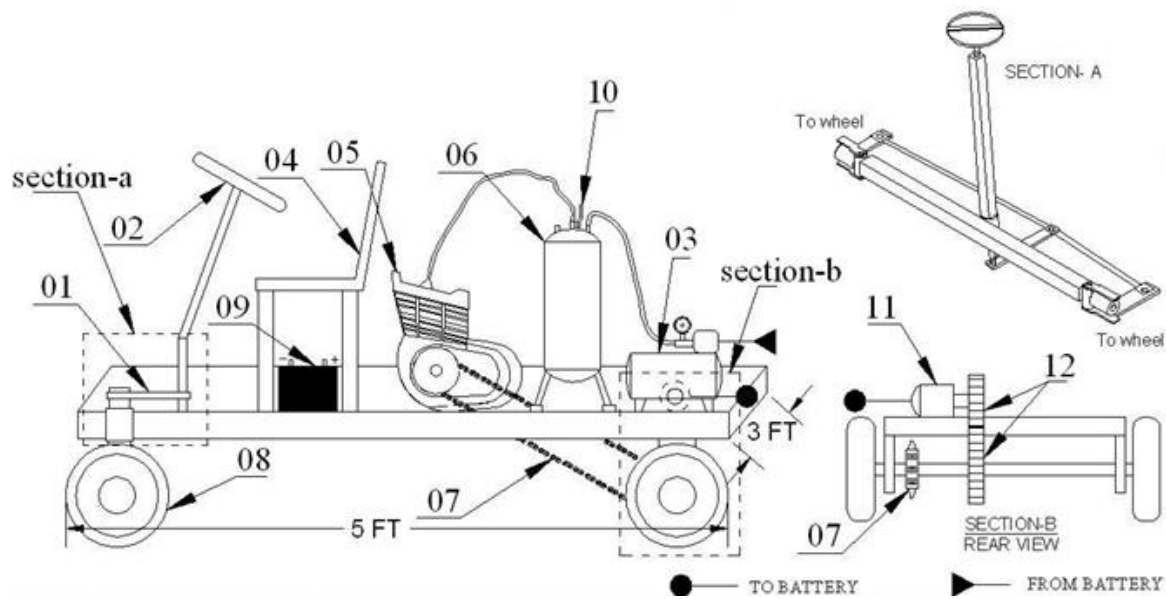

S.NO	PARTS NAME
01	Linkage for turning
02	Steering wheel
03	12 V DC compressor
04	Seat
05	Engine
06	Air tank
07	Chain drive
08	Scooty wheel
09	12 V/7A battery
10	Gate valve
11	Dynamo
12	Spur gear

### 4.3. Working Principle

The main components involved in this project consist of engine, battery, compressor unit, spur gear arrangement and linkages. All components are mounted on the frame called base frame. Here compressor unit is placed at the rear side of the vehicle. 12 Volt DC

compressors are used to compress the air. That compressed air is send directly to the engine inlet. Due to that, engine will function. The engine output shaft is connected with chain drive that tends to rotate the rear wheel. So that vehicle will move forward. Here dynamo is connected to the rear shaft of the vehicle by using spur gear arrangement to generate the electrical power. That

power is stored in battery. At front side of the vehicle, linkages are provided for steering purpose.

## PHOTOGRAPHY



Figure.14. Air driven engine

## MERITS & APPLICATIONS

### 5.1. Merits

We have verification of its performance

- Constant torque
- Low parts count
- Eco friendly
- Compact and light

### 5.2. Applications

- Two wheeler Applications
- Four wheeler Applications

## CONCLUSION

This project is made with pre planning, that it provides flexibility in operation. This innovation has made the more desirable and economical. This project “air driven engine” is designed with the hope that it is very much economical and help full to automobile vehicles. This project helped us to know the periodic steps in

completing a project work. Thus we have completed the project successfully.

## REFERENCES

- a. [www.thedieselstop.com/forums/f45/remote-starter-222054/](http://www.thedieselstop.com/forums/f45/remote-starter-222054/)
- b. [www.alibaba.com/showroom/remote-starter-for-diesel-engine.html](http://www.alibaba.com/showroom/remote-starter-for-diesel-engine.html)
- c. [www.blackwidowsecurity.com/.../s%20series%20complete.pdf](http://www.blackwidowsecurity.com/.../s%20series%20complete.pdf)
- d. [forums.dieselpowermag.com/.../wife-trying-to-surprise-husband-with](http://forums.dieselpowermag.com/.../wife-trying-to-surprise-husband-with)
- e. [www.derand.com/RemoteStarters.html](http://www.derand.com/RemoteStarters.html)
- f. Design data book-P.S.G. Tech.
- g. Machine tool design handbook –Central machine tool Institute, Bangalore.