

TWENTY FIRST CENTURY VEHICLE-BASED ON NON-COVENTIONAL SOURCES WITH ADVANCED FEATURES

Prachi Saxena¹, Alpana Singh², Niharika³, Nidhi Chaudhary⁴, Neha Arora⁵

^{1,3,4,5} Final Year Students, Department of Electronics & Communication Engineering, Moradabad Institute of Technology, Moradabad, Uttar Pradesh, India

prachi.saxena17@yahoo.in¹, niharika_verma26@yahoo.com³, nidhsch@gmail.com⁴, 19neha.arora@gmail.com⁵

² Assistant Professor, Department of Electronics & Communication Engineering, Moradabad Institute of Technology, Moradabad, Uttar Pradesh, India, aalps646@gmail.com²

Abstract-Today, there is huge scarcity of fossil fuels like petrol or diesel for running most of our vehicles. It's really very difficult to imagine our life without these resources, so there is a high need to produce them at faster rate or to find some other alternative to run our vehicles. On the other hand there is an abundance of sources like solar and wind energy present in nature and along with it, in this modern world there is lot of noise pollution on roads. This paper presents the design of a new generation vehicle based on these non-conventional sources along with the advanced feature of anti-collision and automatic headlight system. The vehicle uses a solar panel, dynamos and propellers, piezo-electric crystal, infrared sensor, light dependent resistors, AT89C52 microcontroller, voltage regulator IC 7805, comparator IC LM-358 and a pair of dc gear motor. The supply to the vehicle is provided using non-conventional energy resources i.e., solar, wind and noise energy.

Key Words: DC gear motor, IR sensor, piezo-crystal, LDR, Microcontroller, propeller, automatic headlight system, solar panel, dynamo.

1. INTRODUCTION

In this 21st century, vehicles are deeply indulged in our society and all these vehicles require electricity or fuel to operate. As fast as this world population is rising and due to the drastic progress of mankind the electric and fossil fuel consumption is increasing day by day, on the other hand the production of electric power is limited and these fuels are also scarce. We provide an interesting idea of using nonconventional energy source to drive the vehicle. It means this vehicle is based on advance technology i.e., on green concept of natural occurrence.

- In this we used noise pollution, wind energy and solar energy, these are converted into electrical energy with the help of special technologies. This energy is stored in the battery and this battery supply is used for driving the vehicle.

- The design also consists of an advanced feature of anti-collision using microcontroller and automatic headlight system using light dependent resistor.

2. PROPOSED METHOD

2.1. Basic Principle

Our vehicle is based on green concept of natural occurrence along with the advance feature of anti-collision and automatic headlight system. The three non-conventional sources are connected in parallel to charge the battery.

- **SOUND ENERGY**
We all know sound energy is a mechanical energy which travels in the form of wave, mechanical wave that is an oscillation of pressure which need medium to travel. So, sound is a form of mechanical energy and according to third law of thermodynamics mechanical energy could be converted into electric energy. This sound energy can be converted to electricity by piezo electric material, which converts mechanical strain to electric energy. This electric energy charges the battery [1].
- **SOLAR**
When our vehicle moves in sunny day, sun light charge the solar plate and electric current produces. This current charges the battery with the help of charger circuit.
- **WIND**
A dynamo is a rotating machine which converts mechanical energy into electrical energy by the principles of electromagnetism given by Michael Faraday. When our vehicle moves, air pressure rotate our dynamo fans and dynamo charges the battery with the help of charging circuit.

2.2. Block Diagram

The block diagram of 21st century vehicle is shown in figure 1.

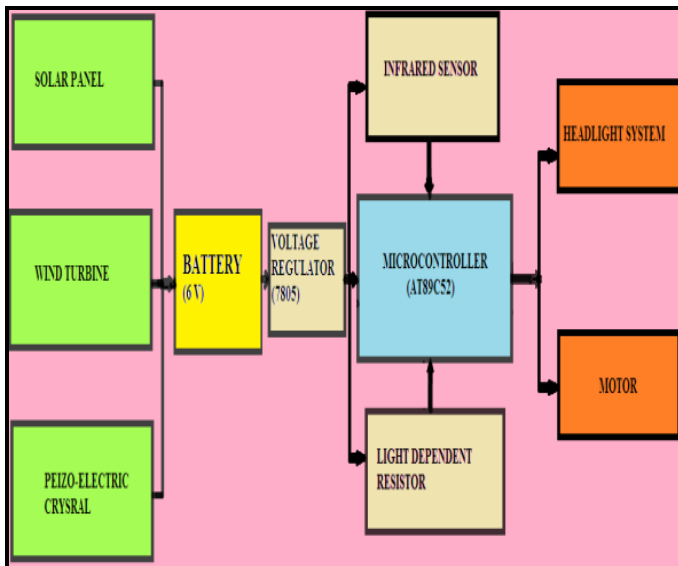

Fig -1: Block diagram of 21st century vehicle

It consists of a solar panel, wind turbine, piezo-electric crystal which altogether charges the battery. Along with these sources, it consist of voltage regulator IC LM7805, microcontroller AT89C52, Light dependent resistor, Infrared sensor and a pair of dc gear motor.

2.3. Working

The working of the system is explained as follows. In this circuit we have used three different sources i.e., solar energy, wind energy and sound energy to generate electrical energy which is stored in a battery to drive the vehicle.



Fig -2: Solar panel

The solar radiations received from sun are converted into electrical energy using solar panel.



Fig -3: Propeller and dynamo for charging battery using wind energy

When the car moves, the blades of propeller rotates due to air flow. This mechanical energy is converted into electrical energy with the help of dynamos.



Fig -4: Glowing LEDs depicting the charging of battery when the vehicle is moving

The oscillations of noise/sound energy produced in the atmosphere by different sources/vehicles create pressure on piezo-electric crystal. This strain is further converted into electrical energy.



Fig -5: Piezo-electric crystal charging the battery using noise source



Fig -7: Circuit showing connection between microcontroller, lm358 and lm7805



Fig -6: Circuit charging the battery using the three sources in parallel

Power supply from battery drives the microcontroller using a voltage regulator IC LM7805. IC LM7805 maintains a constant voltage level of 5 volt and gives the signal to microcontroller and other IC [2].

The anti-collision feature is attained by using an IR (infrared) sensor which senses the object or vehicle in the path automatically within the range of 3-4 cm and send signal to microcontroller with the help of a comparator IC LM-358. As a response to this signal, the microcontroller control the motor movement with the help of driver circuit darling-ton pair of transistor i.e., stops the vehicle to avoid accident.



Fig -8: Motor derives the vehicle as per the microcontroller's output

LDR sensor senses the day/night condition and it operate the head light automatically with the help of comparator IC LM385. The output of this comparator IC acts as an input to microcontroller which controls the headlight system.

2.3.1. Circuit Diagram

The circuit diagram of the 21st century vehicle is shown in figure 5. The compact circuitry of this system is built around the AT89C52 microcontroller. The AT89C52 is a low power, high performance CMOS 8K bytes of Flash programmable and erasable read only memory (PEROM). By combining a versatile 8 bit CPU with flash on a monolithic chip, the Atmel AT89C52 is a powerful microcomputer which provides a highly flexible and cost effective solution to many embedded control applications. The AT89C52 provides the following standard features: 8K bytes of Flash, 256 bytes of RAM, 32 I/O lines, three 16-bit timer/counters, a six-vector two-level interrupt architecture, a full-duplex serial port, on-chip oscillator, and clock circuitry 385 [3].

The other important components are solar panel, propeller, dynamo, piezo-crystal, light dependent resistor, IR sensor, dc gear motors and a battery. The +6V rechargeable battery is charged using the three sources in parallel thin parallel. The anti-collision and automatic headlight system circuit requires +5V power supply to operate.

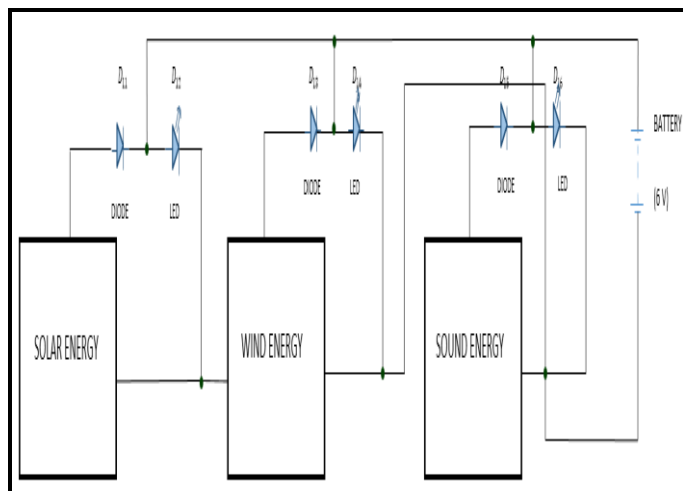

Fig -9: Circuit diagram for battery charging circuit of 21st century vehicle

IC LM7805 regulator can deliver up to 1.5 A of output current. The internal current-limiting and thermal-shutdown feature of this regulator is essentially immune to overload.

In addition to use as fixed-voltage regulator, this device can be used with external components to obtain adjustable output voltages and currents, and also can be used as the power-pass element in precision regulators.

The IC LM385 is micro power 3-terminal adjustable band-gap voltage reference diode. Operating from 1.24 to 5.3V and over a 10 mA to 20 mA current range, they feature exceptionally low dynamic impedance and good temperature stability. On-chip trimming is used to provide

tight voltage tolerance. Further, the wide operating current allows it to replace older references with a tighter tolerance part [4].

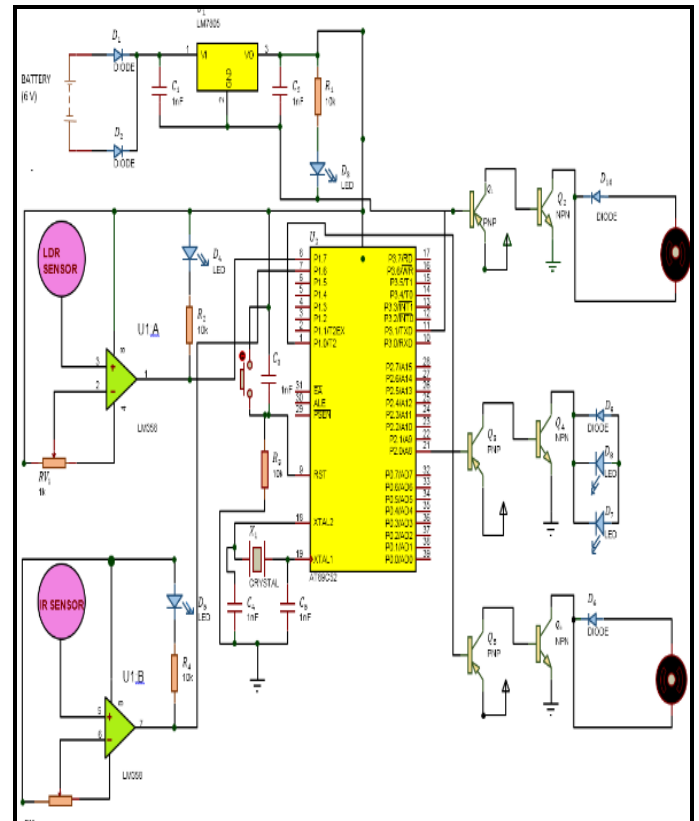

Fig -10: Circuit diagram of automatic headlight and anti-collision for 21st century vehicle

2.3.2. Circuit Simulation

The circuit simulation of the circuit using the proteus software is shown in figure 11. Through this we can check whether the project is working against all the conditions or not.

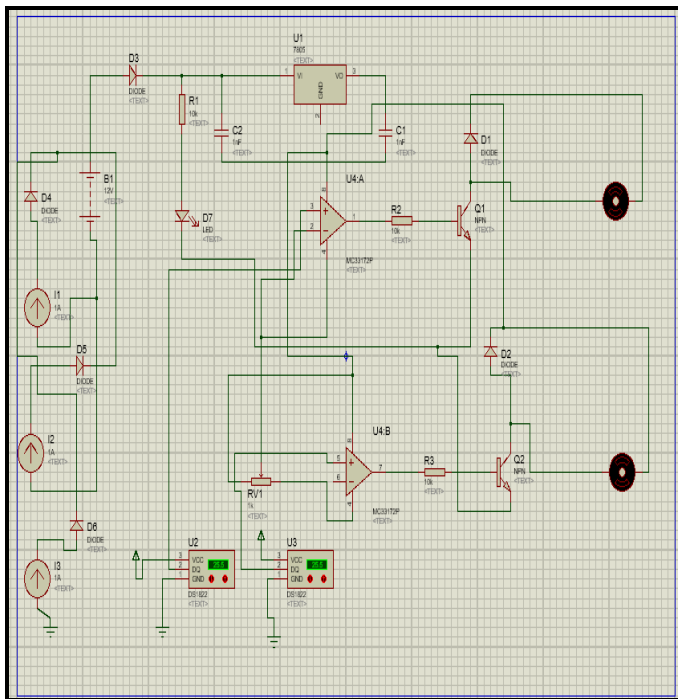

Fig -11 (A): Circuit simulation on proteus of battery charging circuit using three sources and driving motors

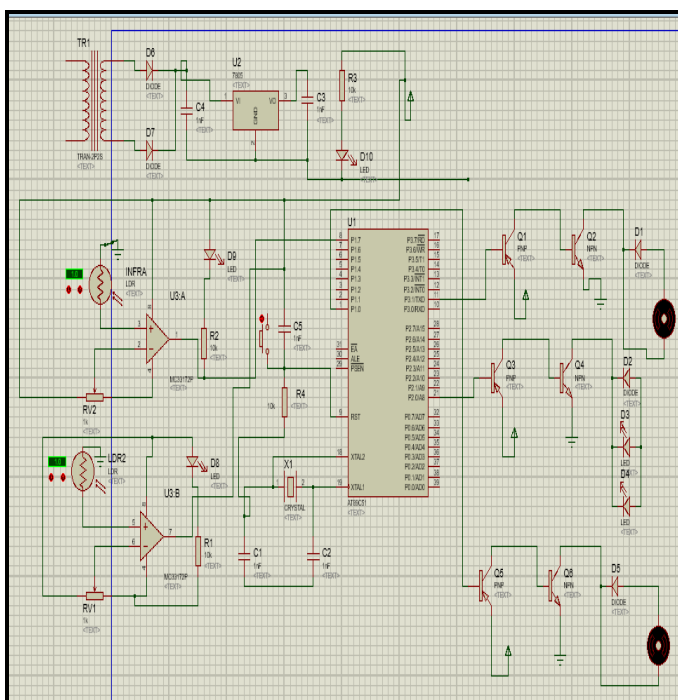

Fig -11(B): Circuit simulation on proteus of advance features like anti-collision and automatic headlight system

3. RESULTS

The following table shows the charging of battery with the help of three non-conventional sources i.e., wind, noise and solar energy: -

TABLE-1: Battery Charging By Three Sources Based On State Of Vehicle And Time

TIME	STATE	Wind	Noise	Solar
Day	Moving state	ON	ON	ON
	Standing State	OFF	ON	ON
Night	Moving state	ON	ON	OFF
	Standing State	OFF	ON	OFF

The following table shows the operation of the system -

TABLE-2: Operation Of Anti-Collision And Automatic Headlights Based On Input To The Microcontroller

Stages	Dc gear Motor	Automatic headlight
P1.7 IS HIGH (SIGNAL FROM LDR)	OFF	OFF
P1.6 IS HIGH (SIGNAL FROM IR SENSOR)	ON	OFF
P1.7 IS LOW (SIGNAL FROM LDR)	OFF	ON
P1.6 IS LOW (SIGNAL FROM IR SENSOR)	ON	ON

4. CONCLUSION

In this project we have used an efficient method for running our vehicle using non-conventional sources. The key feature of this project is, it stops the vehicle detecting any obstacle in the path i.e., having anti-collision feature.

The vehicle also has automatic headlight system based on day and night. There are many more systems like this available in the market but they are not as efficient as this system.

[2] www.sparkfun.com

[3] www.atmel.com

[4] www.elektronik-kompodium.de

ACKNOWLEDGEMENT

With immense pleasure, we would like to express our deeper sense of gratitude to **Mr. KSHITIJ SINGHAL (HOD-E&C Engg.)** and Project In-charge **Mr. Simrat Singh Gill** (Assistant Professor, E&C Deptt.) for his strenuous guidance and giving us an opportunity to carry out our project work in the institute.

We particularly want to express our thanks and respect to our Project Guide **Mrs. Alpana Singh** (Assistant Prof. E&C Deptt.), M.I.T. Moradabad for inspiring us and giving us all the valuable suggestion from time to time. Without who's ever inspiring and illuminating guidance, this work could not have been possible. The immensely grateful indebted to his excellent guidance, valuable suggestions and exalting knowledge and help throughout the course of this study.

We are also grateful to our friends for their cooperation and encouragement throughout the preparation of this project. This project is one of the most significant parts before the successful completion of engineering. Our most humble regards to our parents for extending full cooperation. We are very grateful to the almighty God who is source of energy within us.

REFERENCES

[1] Shalabh Rakesh Bhatnagar (SRB), "Converting sound energy to electric energy", *Proceedings of the International Journal of Emerging Technology and Advanced Engineering* Website: www.ijetae.com (ISSN 2250-2459, Volume 2, Issue 10, October 2012)

BIOGRAPHIES



Prachi Saxena is Final year B.Tech Student studying in Department of Electronics & Communication Engineering at Moradabad Institute of Technology, Moradabad, Uttar Pradesh, India.



Mrs. Alpana Singh is working as an assistant professor in department of Electronics & Communication Engineering at Moradabad Institute of Technology, Moradabad, Uttar Pradesh, India.



Niharika is Final year B.Tech Student studying in Department of Electronics & Communication Engineering at Moradabad Institute of Technology, Moradabad, Uttar Pradesh, India.



Nidhi Chaudhary is Final year B.Tech Student studying in Department of Electronics & Communication Engineering at Moradabad Institute of Technology, Moradabad, Uttar Pradesh, India.



Neha Arora is Final year B.Tech Student studying in Department of Electronics & Communication Engineering at Moradabad Institute of Technology, Moradabad, Uttar Pradesh, India.